

SPLIT TYPE ROOM AIR CONDITIONER INSTALLATION MANUAL (PART NO. 9315342720-02)

ENGLISH

IMPORTANT! Please Read Before Starting

This air conditioning system meets strict safety and operating standards. As the installer or service person, it is an important part of your job to install or service the system so it operates safely and efficiently.

For safe installation and trouble-free operation, you must:

- Carefully read this instruction booklet before beginning.
- Follow each installation or repair step exactly as shown.
- Observe all local, state, and national electrical codes.
- Pay close attention to all danger, warning, and caution notices given in this manual.

WARNING: This symbol refers to a hazard or unsafe practice which can result in severe personal injury or death.

This symbol refers to a hazard or unsafe practice which can result in personal injury and the potential for product or property damage.

Hazard alerting symbols

Electrical

Safety / alert

If Necessary, Get Help

These instructions are all you need for most installation sites and maintenance conditions. If you require help for a special problem, contact your sales/service outlet or your certified dealer for additional instructions.

In Case of Improper Installation

The manufacturer shall in no way be responsible for improper installation or maintenance service, including failure to follow the instructions in this document.

SPECIAL PRECAUTIONS

When Wiring

ELECTRICAL SHOCK CAN CAUSE SEVERE PERSONAL INJURY OR DEATH. ONLY A QUALIFIED, EXPERIENCED ELECTRICIAN SHOULD ATTEMPT TO WIRE THIS SYSTEM.

- Do not supply power to the unit until all wiring and tubing are completed or reconnected and checked.
- Highly dangerous electrical voltages are used in this system. Carefully refer to the wiring diagram and these instructions when wiring. Improper connections and inadequate grounding can cause **accidental injury or death**.

- Ground the unit** following local electrical codes.
- Connect all wiring tightly. Loose wiring may cause overheating at connection points and a possible fire hazard.

When Transporting

Be careful when picking up and moving the indoor and outdoor units. Get a partner to help, and bend your knees when lifting to reduce strain on your back. Sharp edges or thin aluminum fins on the air conditioner can cut your fingers.

When Installing...

...In a Ceiling or Wall

Make sure the ceiling/wall is strong enough to hold the unit's weight. It may be necessary to construct a strong wood or metal frame to provide added support.

...In a Room

Properly insulate any tubing run inside a room to prevent "sweating" that can cause dripping and water damage to walls and floors.

...In Moist or Uneven Locations

Use a raised concrete pad or concrete blocks to provide a solid, level foundation for the outdoor unit. This prevents water damage and abnormal vibration.

...In an Area with High Winds

Securely anchor the outdoor unit down with bolts and a metal frame. Provide a suitable air baffle.

...In a Snowy Area (for Heat Pump-type Systems)

Install the outdoor unit on a raised platform that is higher than drifting snow. Provide snow vents.

When Connecting Refrigerant Tubing

- Keep all tubing runs as short as possible.
- Use the flare method for connecting tubing.
- Apply refrigerant lubricant to the matching surfaces of the flare and union tubes before connecting them, then tighten the nut with a torque wrench for a leak-free connection.
- Check carefully for leaks before starting the test run.

NOTE:

Depending on the system type, liquid and gas lines may be either narrow or wide. Therefore, to avoid confusion the refrigerant tubing for your particular model is specified as either "small" or "large" rather than as "liquid" or "gas".

When Servicing

- Turn the power OFF at the main circuit breaker panel before opening the unit to check or repair electrical parts and wiring.
- Keep your fingers and clothing away from any moving parts.
- Clean up the site after you finish, remembering to check that no metal scraps or bits of wiring have been left inside the unit being serviced.
- After installation, explain correct operation to the customer, using the operating manual.

This air conditioner uses new refrigerant HFC (R410A).

The basic installation work procedures are the same as conventional refrigerant (R22) models. However, pay careful attention to the following points:

- Since the working pressure is 1.6 times higher than that of conventional refrigerant(R22) models, some of the piping and installation and service tools are special.(See the table below.) Especially, when replacing a conventional refrigerant(R22) model with a new refrigerant R410A model, always replace the conventional piping and flare nuts with the R410A piping and flare nuts.
- Models that use refrigerant R410A have a different charging port thread diameter to prevent erroneous charging with conventional refrigerant(R22) and for safety. Therefore, check beforehand.[The charging port thread diameter for R410A is 1/2 threads per inch.]
- Be more careful that foreign matter (oil, water, etc.) does not enter the piping than with refrigerant(R22) models. Also, when storing the piping ,securely seal the opening by pinching, taping, etc.
- When charging the refrigerant, take into account the slight change in the composition of the gas and liquid phases, and always charge from the liquid phase side whose composition is stable.

Special tools for R410A

Tool name	Contents of change
Gauge manifold	Pressure is high and cannot be measured with a conventional gauge. To prevent erroneous mixing of other refrigerants, the diameter of each port has been changed. It is recommended the gauge with seals-0.1 to 5.3 MPa (-1 to 53 bar) for high pressure. -0.1 to 3.8 MPa (-1 to 38 bar) for low pressure.
Charge hose	To increase pressure resistance, the hose material and base size were changed.
Vacuum pump	A conventional vacuum pump can be used by installing a vacuum pump adapter.
Gas leakage detector	Special gas leakage detector for HFC refrigerant R410A.

Copper pipes

It is necessary to use seamless copper pipes and it is desirable that the amount of residual oil is less than 40 mg/100m. Do not use copper pipes having a collapsed, deformed or discolored portion (especially on the interior surface). Otherwise, the expansion valve or capillary tube may become blocked with contaminants. As an air conditioner using R410A incurs pressure higher than when using R22, it is necessary to choose adequate materials. Thicknesses of copper pipes used with R410A are as shown in the table. Never use copper pipes thinner than that in the table even when it is available on the market.

CONNECTION PIPE REQUIREMENT

Nominal diameter	Outer diameter	Thickness	Maximum length	Maximum height between indoor and outdoor
3/8in	9.52mm	0.8mm	50m(165ft)	30m(99ft)
5/8in	15.88mm	1.0mm		

WARNING

- Do not use the existing (for R22) piping and flare nuts.
 - If the existing materials are used, the pressure inside the refrigerant cycle will rise and cause breakage, injury, etc. (Use the special R410A materials.)
- When installing and relocating the air conditioner, do not mix gases other than the specified refrigerant(R410A) to enter the refrigerant cycle.
 - If air or other gas enters the refrigerant cycle, the pressure inside the cycle will rise to an abnormally high value and cause breakage, injury, etc.

CAUTION

When installing pipes shorter than 17ft (5m), sound of the outdoor unit will be transferred to the indoor unit, which will cause large operating sound or some abnormal sound.

INDOOR UNIT CUTTING THE HOLE IN THE WALL FOR THE CONNECTING PIPING

- Cut a 3-1/8"(80 mm) diameter hole in the wall at the position shown in the figure.
- When cutting the wall hole at the inside of the wall hook bracket, cut the hole to a point of intersection of center marks. When cutting the wall hole at the outside of the wall hook bracket, cut the hole at a point of 10mm below.
- Cut the hole so that the outside end is lower (3/16" to 3/8" (5 to 10 mm)) than the inside end.
- Always align the center of the wall hole. If misaligned, water leakage will occur.
- Cut the wall pipe to match the wall thickness, stick it into the wall cap, fasten the cap with vinyl tape, and stick the pipe through the hole. (The connection pipe is supplied in the installation set.)
- For left piping and right piping, cut the hole a little lower so that drain water will flow freely.

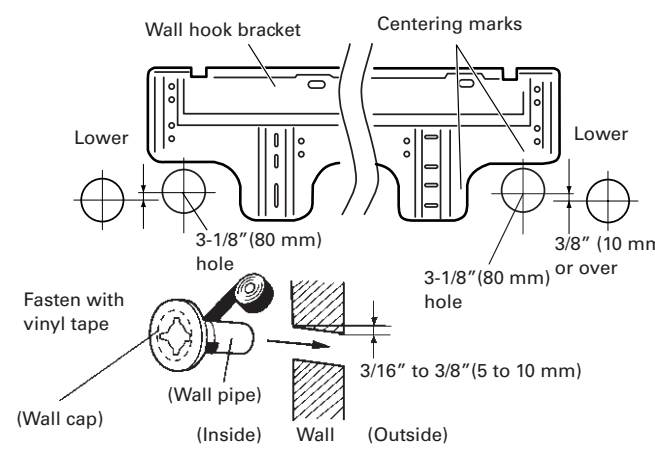

INSTALLING THE WALL HOOK BRACKET

- Install the wall hook bracket so that it is correctly positioned horizontally and vertically. If the wall hook bracket is tilted, water will drip to the floor.
- Install the wall hook bracket so that it is strong enough to withstand the weight of an adult.
 - Fasten the wall hook bracket to the wall with 6 or more screws through the holes near the outer edge of the bracket.
 - Check that there is no rattle at the wall hook bracket.

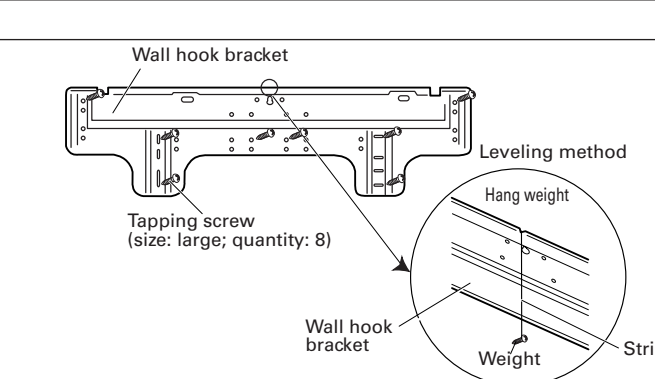

WARNING

If the wall pipe is not used, the cord interconnecting the indoor and outdoor units may touch metal and cause electric leakage.

CAUTION

Install the wall hook bracket horizontally and perpendicularly.

FORMING THE DRAIN HOSE AND PIPE

[Rear piping, Right piping, Bottom piping]

- Install the indoor unit piping in the direction of the wall hole and bind the drain hose and pipe together with vinyl tape.
- Install the piping so that the drain hose is at the bottom.
- Wrap the pipes of the indoor unit that are visible from the outside with decorative tape.

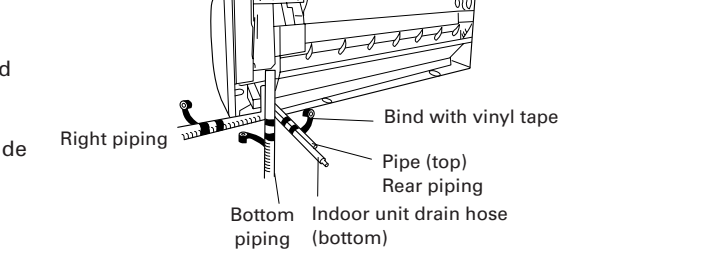

[For Left rear piping, Left piping]

Interchange the drain cap and the drain hose.

CAUTION

- In order to align the drain hose and drain cap, be sure to insert securely and vertically. Incline insertion will cause water leakage.
- When inserting, be sure not to attach any material besides water. If any other material is attached, it will cause deterioration and water leakage.
- After removing drain hose, be sure not to forget mounting drain cap.
- Be sure to fix the drain hose with tape to the bottom of piping.
- Prevent drain water frozen under low temperature environment.
 - When installing indoor unit's drain hose outdoors, necessary measure for frost protection should be taken to prevent drain water frozen.
 - Under low temperature environment (when outdoor temperature under 32 °F), after cooling operation is executed, water in the drain hose could be frozen. Once drain water is frozen, the drain hose will be blocked and water leakage may be resulted for indoor unit.

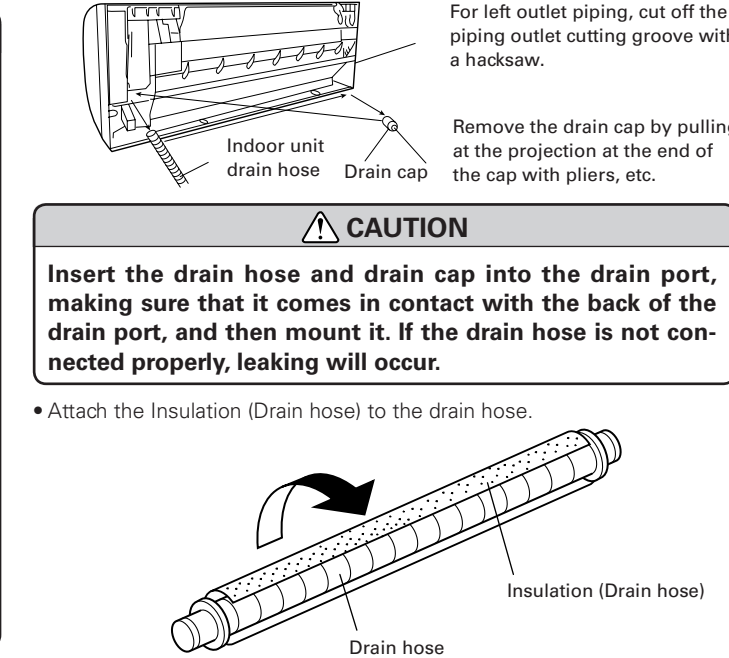

GENERAL

This INSTALLATION MANUAL briefly outlines where and how to install the air conditioning system. Please read over the entire set of instructions for the indoor and outdoor units and make sure all accessory parts listed are with the system before beginning.

1. TYPE OF COPPER PIPE AND INSULATION MATERIAL

Copper tubing for connectin the outdoor unit to the indoor unit and insulation material is available for purchase locally. When you purchase them, please specify the following.

A. Deoxidized annealed copper pipe for refrigerant piping as:

Small pipe		Large pipe	
Outer diameter	Thickness	Outer diameter	Thickness
3/8" (9.52 mm)	0.031496 in (0.8 mm)	5/8" (15.88 mm)	0.03937 in (1.0 mm)

Cut each pipe to the appropriate length +12" (30 cm) to 16" (40 cm) to dampen vibration between units.

B. Foamed polyethylene insulation for copper pipes as required to precise length of piping. Wall thickness of the insulation should not be less than 5/16" (8 mm).

C. Use insulated copper wire for field wiring.

CAUTION

Check local electrical codes and regulations before obtaining wire. Also, check any specified instructions or limitations.

2. ADDITIONAL MATERIALS REQUIRED FOR INSTALLATION

- Refrigeration (armored) tape
- Insulated staples or clamps for connecting wire (See your local electrical codes.)

C. Putty

D. Refrigeration lubricant

E. Clamps or saddles to secure refrigerant piping

3. OPERATING RANGE

	MODEL	Cooling/Dry Mode	Heating Mode
Outdoor temperature	18Y	About 5 to 115 °F	About 5 to 75 °F
	24Y	About 0 to 115 °F	About 0 to 75 °F
Indoor temperature	—	About 64 to 90 °F	86 °F or less
Indoor humidity	—	About 80% or less	—

ADDITIONAL CHARGE

Refrigerant suitable for a piping length of 66 ft (20 m) is charged in the outdoor unit at the factory. When the piping is longer than 66 ft (20 m), additional charging is necessary. For the additional amount, see the table below.

Pipe length	99 ft (30 m)	131 ft (40 m)	165 ft (50 m)
Additional refrigerant	14.2 oz (400 g)	1 lb 12 oz (800 g)	2 lb 10 oz (1200 g)

Between 66 ft (20 m) and 165 ft (50 m), when using a connection pipe other than that in the table, charge additional refrigerant with 0.43 oz / ft (40g/m) as the criteria.

CAUTION

- When adding refrigerant, add the refrigerant from the charging port at the completion of work.
- The maximum length of the piping is 165 ft (50 m). If the units are further apart than this, correct operation can not be guaranteed.

STANDARD ACCESSORIES

The following installation accessories are supplied. Use them as required.

Name and Shape	Q'ty	Name and Shape	Q'ty
Wall hook bracket	1	Cloth tape	1
Remote controller	1	Tapping screw (big)	8
Battery	2	Tapping screw (small)	2
Remote controller holder	1	Insulation (Drain hose)	1
Drain pipe (Reverse cycle model only)	1	Drain cap	5

The following items are necessary to install this air conditioner. (The items are not included with the air conditioner and must be purchased separately.)

Name	Q'ty
Connection pipe assembly	1
Connection cord	1
Wall pipe	1
Decorative tape	1
Vinyl tap	1
Wall cap	1
Saddle	1 set
Drain hose	1 set
Tapping screws	1 set
Sealant	1
M10 bolt, nut	4 set

ELECTRICAL REQUIREMENT

Always make the air conditioner power supply a special branch circuit and provide a special switch and receptacle. Do not extend the power cord.

CAUTION

MODEL	18Y	24Y
MINIMUM CIRCUIT AMPACITY	17 A	18 A
MAXIMUM OVERCURRENT PROTECTION (TIME DELAY FUSE OR HACR TYPE CIRCUIT BREAKER)	20 A	30 A

SELECTING THE MOUNTING POSITION

Decide the mounting position with the customer as follows:

1. INDOOR UNIT

- Install the indoor unit level on a strong wall which is not subject to vibration.
- The inlet and outlet ports should not be obstructed : the air should be able to blow all over the room.
- Install the unit near an electric outlet or special branch circuit.
- Do not install the unit where it will be exposed to direct sunlight.
- Install the unit where connection to the outdoor unit is easy.
- Install the unit where the drain pipe can be easily installed.
- Take servicing, etc. into consideration and leave the spaces shown in the figure. Also install the unit where the filter can be removed.

2. OUTDOOR UNIT

- If possible, do not install the unit where it will be exposed to direct sunlight. (If necessary, install a blind that does not interfere with the air flow.)
- Do not install the unit where a strong wind blows or where it is very dusty.
- Do not install the unit where people pass.
- Take your neighbors into consideration so that they are not disturbed by air blowing into their windows or by noise.
- Provide the space shown in the figure so that the air flow is not blocked. Also for efficient operation, leave open three of the four directions front, rear, and both sides.

WARNING

Install at a place that can withstand the weight of the indoor and outdoor units and install positively so that the units will not topple or fall.

CAUTION

- Do not install where there is the danger of combustible gas leakage.
- Do not install near heat sources.
- If children under 10 years old may approach the unit, take preventive measures so that they cannot reach the unit.
- Install the indoor unit on the wall where the height from the floors more than 180 cm.

[Indoor unit piping direction]

The piping can be connected in the 7 directions in the figure. When the piping is connected in direction ②, ③, ④ or ⑤, cut along the piping groove in the side of the front panel with a hacksaw.

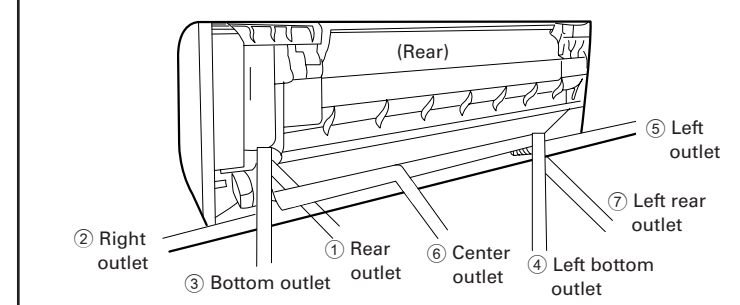

INSTALLATION DIAGRAM OF INDOOR AND OUTDOOR UNITS

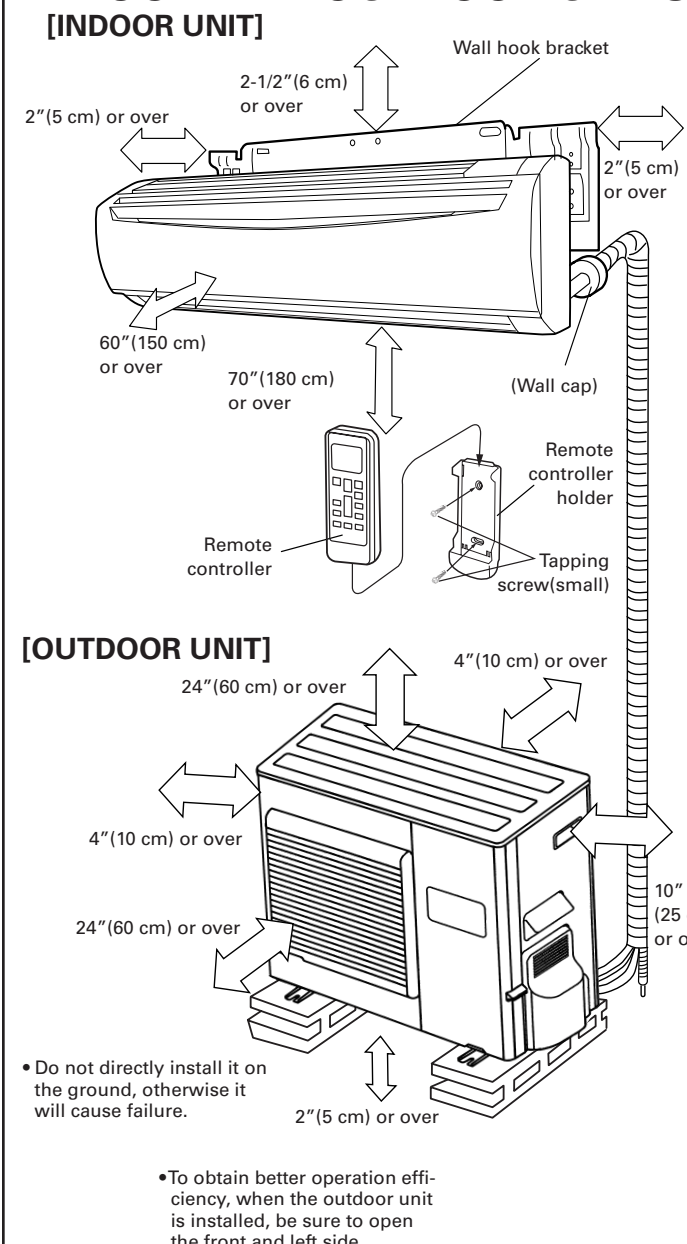

CAUTION

- When the outdoor temperature is 32 °F or less, do not use the accessory drain pipe and drain cap. If the drain pipe and drain cap are used, the drain water in the pipe may freeze in extremely cold weather. Reverse cycle model only.
- In the area with heavy snowfall, if the intake and outlet of outdoor unit is blocked with snow, it is likely to cause the breakdown. Please construct a canopy and a pedestal or place the unit on a high stand (local configured).

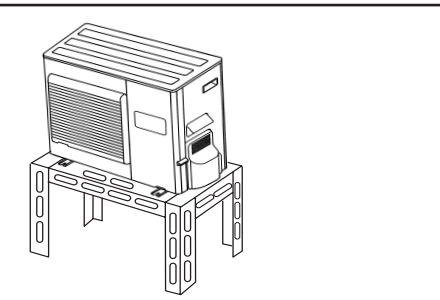

ELECTRICAL WIRING (INDOOR UNIT)

HOW TO THE INSTALL THE INTER-UNIT WIRE HARNESS

- Remove the screws, then remove the conduit holder.
- Fasten the inter-unit wire harness to the conduit holder using the lock nut. IMPORTANT: Refer to figure of inlet-unit wire length about the length of inter-unit wire harness.
- Use the screws to install the conduit holder with which Inter-unit wire harness is included.
- Remove the screws, then remove the cord clamp.
- Connect inter-unit wire harness to the terminal. Refer to the wiring diagram.
- Use the screws to install the cord clamp.

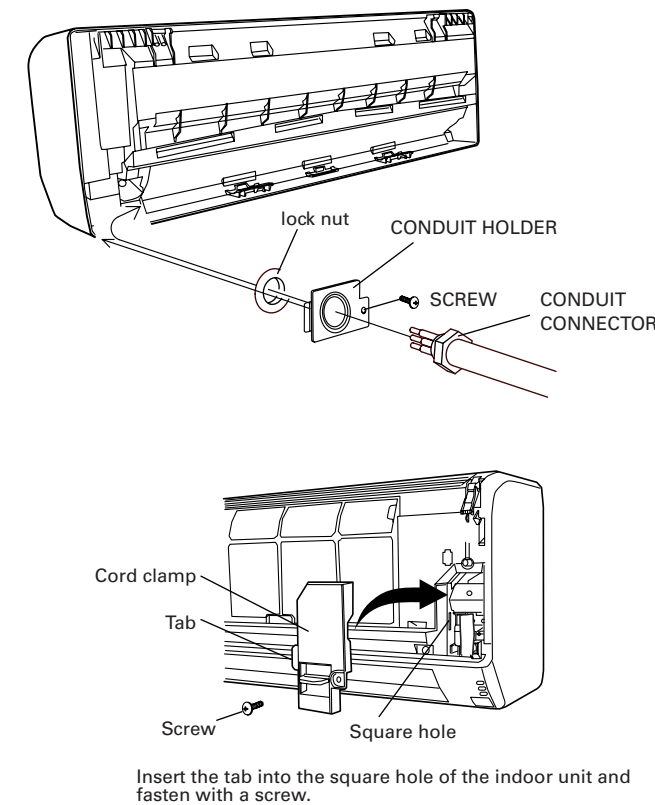

HOW TO CONNECT WIRING TO THE TERMINALS

A. For solid core wiring (or F-cable)

- Cut the wire end with a wire cutter or wire-cutting pliers, then strip the insulation to about 15/16" (25 mm) to expose the solid wire.
- Using a screwdriver, remove the terminal screw(s) on the terminal board.
- Using pliers, bend the solid wire to form a loop suitable for the terminal screw.
- Shape the loop wire properly, place it on the terminal board and tighten screw using a screwdriver.

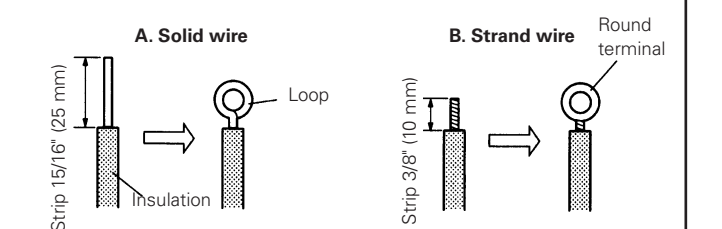

B. For strand wiring

- Cut the wire end with a wire cutter or wire-cutting pliers, then strip the insulation to about 3/8" (10 mm) to expose the strand wiring.
- Using a round terminal fastener or pliers, securely clamp a round terminal to each stripped wire end.
- Position the round terminal wire, and replace and tighten the terminal screw using a screwdriver.

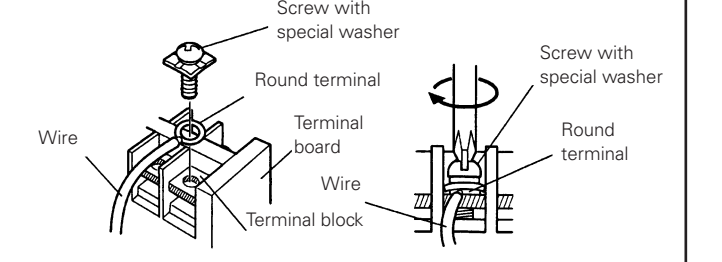

CAUTION

- Match the terminal block numbers and connection cord colors with those of the outdoor unit. Erroneous wiring may cause burning of the electric parts.
- Connect the connection cords firmly to the terminal block. Imperfect installation may cause a fire.
- Always fasten the outside covering of the connection cord with the cord clamp. (If the insulator is chafed, electric leakage may occur.)
- Always connect the ground wire.
- Do not use the earth screw for an external connector. Only use for interconnection between two units.

- For left piping and left rear piping, align the marks on the wall hook bracket and shape the connection pipe.
- Bend the connection piping at the bend radius of 4"(100 mm) or more and install no more than 1-3/8" (35 mm) from the wall.
- After passing the indoor piping and drain hose through the wall hole, hang the indoor unit on the hooks at the top and bottom of the wall hook bracket.

[Installing the indoor unit]

- Hang the indoor unit from the hooks at the top of the wall hook bracket.
- Insert the spacer, etc. between the indoor unit and the wall hook bracket and separate the bottom of the indoor unit from the wall.

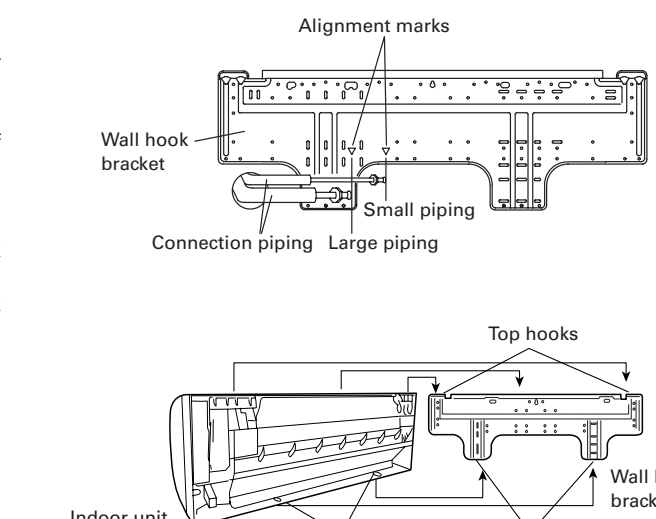
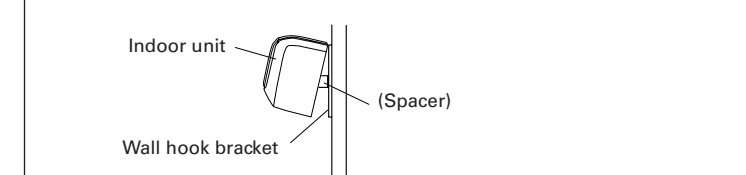

After hooking the indoor unit to the top hook, hook the fittings of the indoor unit to the two bottom hooks while lowering the unit and pushing it against the wall.

CONNECTING THE PIPING

CONNECTION

- Install the outdoor unit wall cap (supplied with the optional installation set or procured at the site) to the wall pipe.
- Connect the outdoor unit and indoor unit piping.
- After matching the center of the flare surface and tightening the nut hand tight, tighten the nut to the specified tightening torque with a torque wrench.

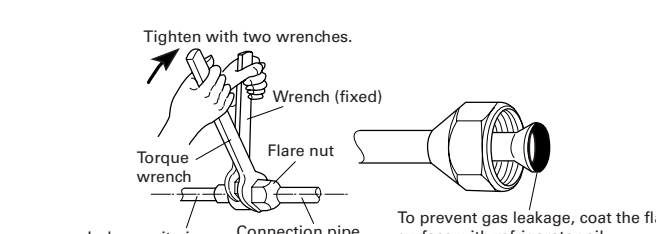

FLARING

Insert the flare nut (always use the flare nut attached to the indoor and outdoor units respectively) onto the pipe and perform the flare processing with a flare tool.

- Hold the pipe downward so that cuttings will not enter the pipe and remove the burrs.
- Insert the flare nut onto the pipe and flare the pipe with a flaring tool.

OUTDOOR UNIT

OUTDOOR UNIT INSTALLATION

WARNING

- Install the unit where it will not be tilted by more than 3°. However, do not install the unit with it tilted towards the side containing the compressor.
- When installing the outdoor unit where it may be exposed to strong wind, fasten it securely.

- Outdoor unit to be fasten with bolts at the four places indicated by the arrows without fail.

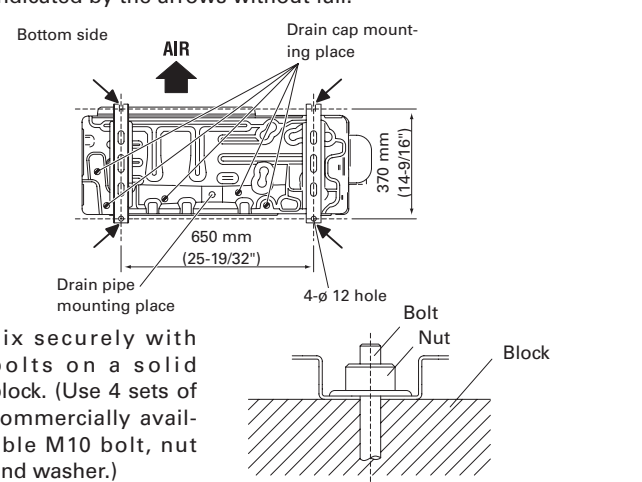

CAUTION

When the outdoor temperature is 32 °F or less, do not use the accessory drain pipe and drain cap. If the drain pipe and drain cap are used, the drain water in the pipe may freeze in extremely cold weather. (Reverse cycle model only)

AIR PURGE

- Remove the cap, and connect the gauge manifold and the vacuum pump to the charging valve by the service hoses.
- Vacuum the indoor unit and the connecting pipes until the pressure gauge indicates -0.1 MPa (-76 cmHg).
- When -0.1 MPa (-76 cmHg) is reached, operate the vacuum pump for at least 60 minutes.
- Disconnect the service hoses and fit the cap to the charging valve to the specified torque.
- Remove the blank caps, and fully open the spindles of the 3-way valves with a hexagon wrench [Torque: 6-7 N·m (to 70 kgf·cm)].
- Tighten the blank caps of the 3-way valve to the specified torque.

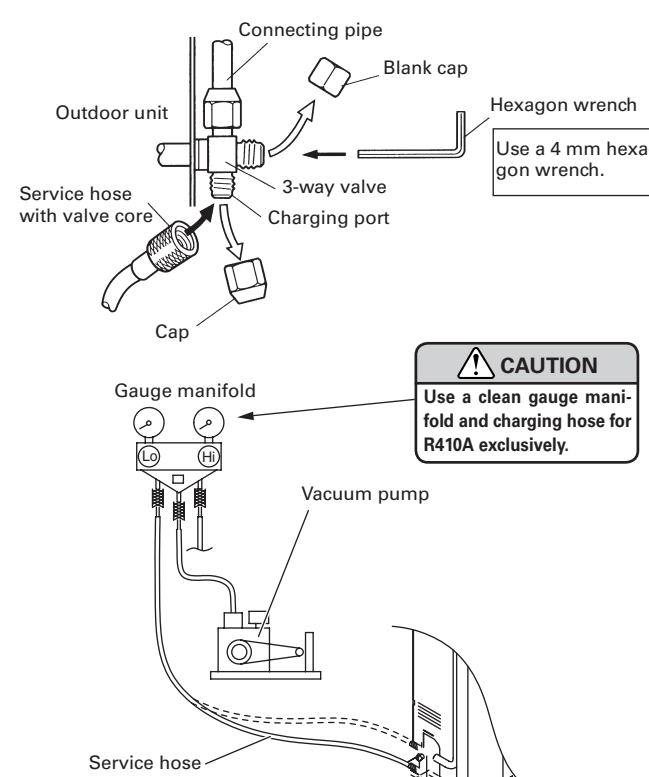

CAUTION

Use a clean gauge manifold and charging hose for R410A exclusively.

	Tightening torque
Blank cap	9.52 mm (3/8 in.) 20 to 25 N·m (200 to 250 kgf·cm) 15.88 mm (5/8 in.) 30 to 35 N·m (300 to 350 kgf·cm)
Charging port cap	10 to 12 N·m (100 to 120 kgf·cm)

WARNING

If refrigerant leaks while work is being carried out, ventilate the area. If the refrigerant comes in contact with a flame, it produces a toxic gas.

CAUTION

- Do not purge the air with refrigerants, but use a vacuum pump to vacuum the installation! There is no extra refrigerant in the outdoor unit for air purging!
- Use a vacuum pump and gauge manifold and charging hose for R410A exclusively. Using the same vacuum for different refrigerants may damage the vacuum pump or the unit.
- After connecting the piping, check the all joints for gas leakage with gas leak detector.
- When inspecting gas leakage, always use the vacuum pump for pressure. Do not use nitrogen gas.

ELECTRICAL WIRING (OUTDOOR UNIT)

CAUTION

When connecting the power supply cord, make sure that the phase of the power supply matches with the phase of the terminal board. If the phases do not match, the compressor will rotate in reverse and will not be able to compress.

- Service cover removal
 - Remove the two mounting screws.
 - Remove the service cover by pushing downwards.
- Fasten the power supply cord and the connection cord to the conduit holder using the lock nut. (open the knock out holes if necessary)
- Connect the power supply cord and the connection cord to terminal.
- Fasten the power supply cord and connection cord with cord clamp.

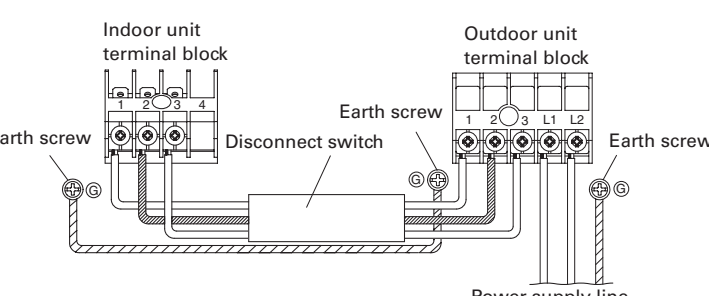
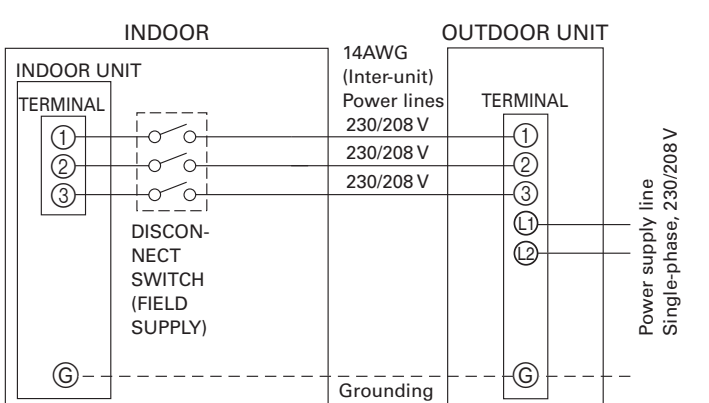
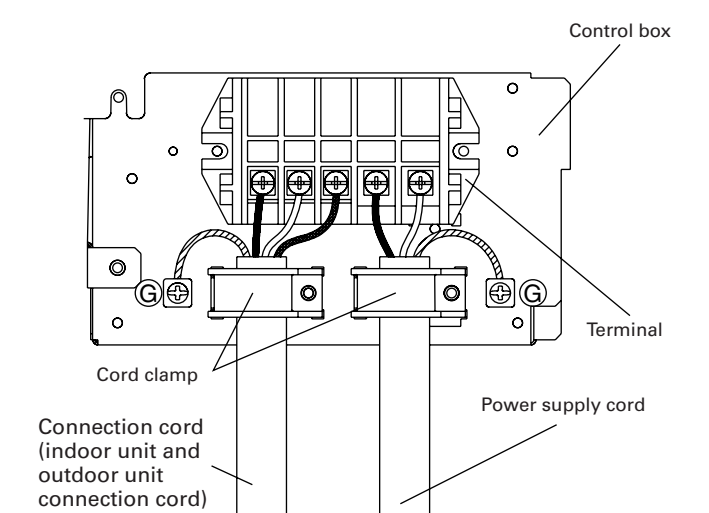

NOTE:
Factory installed protective inline fuses for indoor units' conductors are installed on the Power Supply PCB.

Keep the earth wire longer than the other wires.

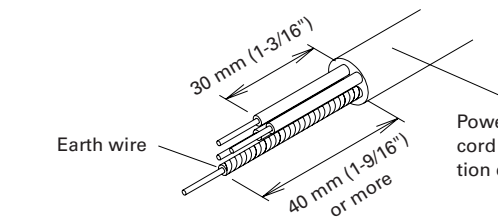

WARNING

Disconnect switch for current protection given in the table below is to be installed between the indoor unit and the outdoor unit.

Disconnect switch

20A

CAUTION

Be sure to comply with local codes while running the wire from the indoor unit to the outdoor unit (size of wire and wiring method, etc.).
Every wire must be connected firmly.
No wire should be allowed to touch refrigerant tubing, the compressor or any moving part.
Loose wiring may cause the terminal to overheat or result in unit malfunction. A fire hazard may also exist. Therefore, be sure all wiring is tightly connected.
Connect wires to the matching numbers of terminals.

REMOTE CONTROLLER INSTALLATION

CAUTION

- Check that the indoor unit correctly receives the signal from the remote controller, then install the remote controller holder.
- Select the remote controller holder selection site by paying careful attention to the following:
Avoid places in direct sunlight.
Select a place that will not be affected by the heat from a stove, etc.

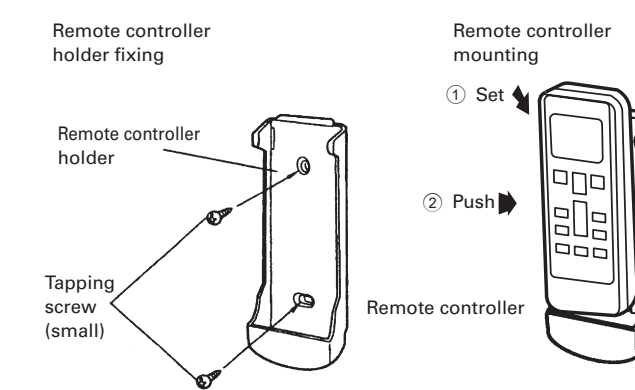

1. REMOTE CONTROLLER HOLDER INSTALLATION

- Install the remote controller with a distance of 23 ft (7 m) between the remote controller and the photocell as the criteria. However, when installing the remote controller, check that it operates positively.
- Install the remote controller holder to a wall, pillar, etc. with the tapping screw.

PUMP DOWN OPERATION (FORCED COOLING OPERATION)

To avoid discharging refrigerant into the atmosphere at the time of relocation or disposal, recover refrigerant by doing the cooling operation or forced cooling operation according to the following procedure. (When the cooling operation cannot start in winter, and so on, start the forced cooling operation.)

- Do the air purging of the charge hose by connecting the charging hose of gauge manifold to the charging port of 3 way valve (large) and opening the low-pressure valve slightly.
- The operation indicator lamp and timer indicator lamp will begin to flash simultaneously during test run.
- Start the cooling operation or following forced cooling operation. When using the remote controller, Press the TEST RUN button after starting the cooling operation by the remote controller. The operation indicator lamp and timer indicator lamp will begin to flash simultaneously during test run. When using the MANUAL AUTO button of the indoor unit (The remote controller is lost, and so on.) Keep on pressing the MANUAL AUTO button of the indoor unit for more than 10 seconds. (The forced cooling operation cannot start if the MANUAL AUTO button is not kept on pressing for more than 10 seconds.)
- Close the valve stem of 3 way valve (large) when the reading on the compound pressure gage becomes 0.05-0 MPa (0.5-0 kgf/cm²).
- Stop the operation.
 - Press the START/STOP button of the remote controller to stop the operation.
 - Press the MANUAL AUTO button when stopping the operation from indoor unit side. (It is not necessary to press on keeping for more than 10 seconds.)

CAUTION

During the pump-down operation, make sure that the compressor is turned off before you remove the refrigerant piping. Do not remove the connection pipe while the compressor is in operation 3 way valve open. This may cause abnormal pressure in the refrigeration cycle that leads to breakage and even injury.

CAUTION

Install heat insulation around both the gas and liquid pipes. Failure to do so may cause water leaks. Use heat insulation with heat resistance above 248 °F (Reverse cycle model only). In addition, if the humidity level at the installation location of the refrigerant piping is expected to exceed 70%, install heat insulation around the refrigerant piping. If the expected humidity level is 70-80%, use heat insulation that is 15 mm or thicker and if the expected humidity exceeds 80%, use heat insulation that is 20 mm or thicker. If heat insulation is used that is not as thick as specified, condensation may form on the surface of the insulation. In addition, use heat insulation with heat conductivity of 0.045 W/(m·K) or less (at 68 °F).

FINISHING

- Insulate between pipes.
 - For rear, right, and bottom piping, overlap the connection pipe heat insulation and indoor unit pipe heat insulation and bind them with vinyl tape so that there is no gap.
 - For left and left rear piping, butt the connection pipe heat insulation and indoor unit pipe heat insulation together and bind them with vinyl tape so that there is no gap.
 - For left and left rear piping, wrap the area which accommodates the rear piping housing section with cloth tape.
 - For left and left rear piping, bind the connection cord to the top of the pipe with vinyl tape.
 - For left and left rear piping, bundle the piping and drain hose together by wrapping them with cloth tape over the range within which they fit into the rear piping housing section.
- Temporarily fasten the connection cord along the connection pipe with vinyl tape. (Wrap to about 1/3 the width of the tape from the bottom of the pipe so that water does not enter.)
- Fasten the connection pipe to the outside wall with saddles, etc.
- Fill the gap between the outside wall pipe hole and the pipe with sealer so that rain water and wind cannot blow in.
- Fasten the drain hose to the outside wall, etc.

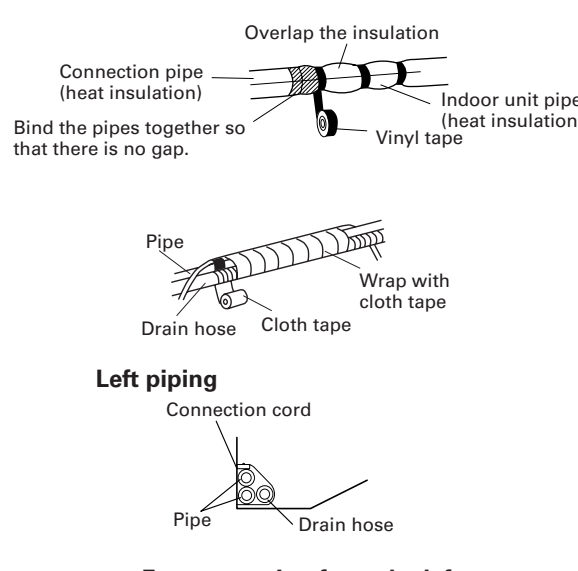

FRONT PANEL REMOVAL AND INSTALLATION

THE INTAKE GRILLE REMOVAL

- Open the intake grille.
- Pull down the knob.
- Lift the intake grille upward, until the axle at the top of the intake grille is removed.

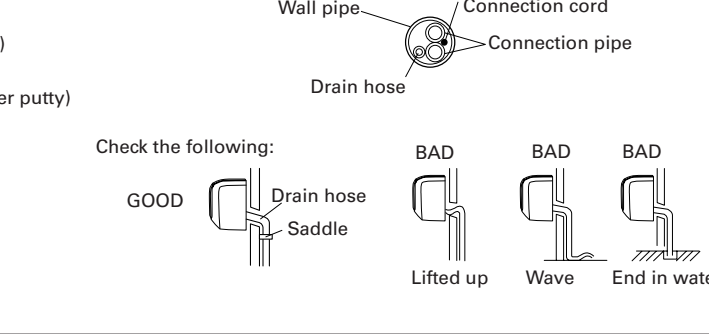

THE INTAKE GRILLE INSTALLATION

- The fixing axle of the intake grille is installed on the Panel.
- Lay down the intake grille.

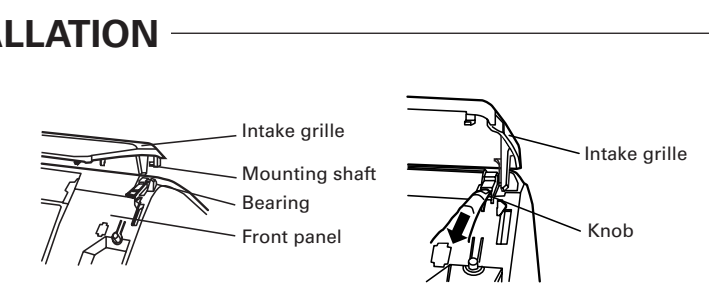

THE FRONT PANEL REMOVAL

- Remove intake grille. (Reference the intake grille removal.)
- Remove six screws.
- The thumb is hung on the lower part as shown in the figure, and it pulls to the front, pushing [-] mark, and bottom hooks (two position) is removed from wall hook bracket.
- The front panel is pulled to the front, raising the upper surface, and a front panel is removed.

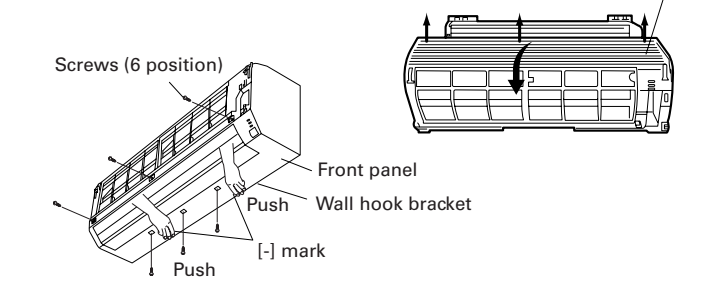

THE FRONT PANEL INSTALLATION

- Firstly, fit the lower part of the front panel, and insert top and bottom hooks. (Three top sides)
- Six screws is attached.
- The intake grille is attached.

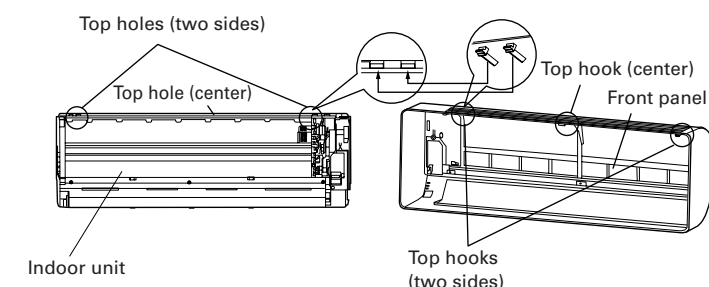

CAUTION

Install the front panel and INTAKE GRILLE securely. If installation is imperfect, the front panel or INTAKE GRILLE may fall off and cause injury.

TEST RUNNING

WARNING

Do not turn on the power until all installation work is complete.

CAUTION

When restarting after a long period of disuse in the winter, turn the power switch on at least 12 hours before starting the unit.

- Perform test operation and check items 1 and 2 below.
 - For the test operation method, refer to the operating manual.
 - The outdoor unit, may not operate, depending on the room temperature. In this case, press the test run button on the remote controller while the air conditioner is running. (Point the transmitter section of the remote controller toward the air conditioner and press the test run button with the tip of a ball-point pen, etc.)
 - To end test operation, press the remote controller START/STOP button. (When the air conditioner is run by pressing the test run button, the OPERATION indicator lamp and TIMER indicator lamp will simultaneously flash slowly.)
- INDOOR UNIT**
 - Is operation of each button on the remote controller normal?
 - Does each lamp light normally?
 - Do the air flow-direction louver operate normally?
 - Is the drain normal?
 - OUTDOOR UNIT**
 - Is there any abnormal noise and vibration during operation?
 - Will noise, wind, or drain water from the unit disturb the neighbors?
 - Is there any gas leakage?

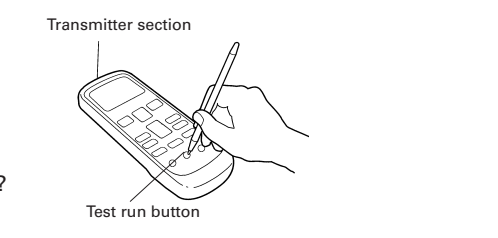

POWER

WARNING

- The rated voltage of this product is 208/230 V AC 60 Hz.
- Before turning on the power, check if the voltage is within the 208 V -10 % to 230 V +10 % range.
- Always use a special branch circuit and install a special receptacle to supply power to the room air conditioner.
- Use a circuit breaker and receptacle matched to the capacity of the air conditioner.
- Do not extend the power cord.
- Perform wiring work in accordance with standards so that the air conditioner can be operated safely and positively.
- Install a leakage circuit breaker in accordance with the related laws and regulations and electric company standards.

CAUTION

- The power source capacity must be the sum of the air conditioner current and the current of other electrical appliances. When the current contracted capacity is insufficient, change the contracted capacity.
- When the voltage is low and the air conditioner is difficult to start, contact the power company the voltage raised.

CUSTOMER GUIDANCE

Explain the following to the customer in accordance with the operating manual:
(1) Starting and stopping method, operation switching, temperature adjustment, timer, air flow switching, and other remote controller operations.
(2) Air filter removal and cleaning, and how to use the air louvers.
(3) Give the operating and installation manuals to the customer.

OPTIONAL KIT INSTALLATION(OPTION)

This air conditioner can be connected with the following optional kits.

- Wired remote controller
- External input/output kit

BEFORE INSTALL WIRED REMOTE CONTROLLER

- When you use wired remote controller, some functions may not be used.
- Please use the recommended wired remote controller.

CAUTION

- Before installing, be sure to disconnect all power supply.
- Don't touch the heat exchanger.
- During installing or removing operation, be sure not to have wire caught by parts or draw it hard. Or it may result troubles to the air-conditioner.
- Avoid place in direct sunlight.
- Select place that will not be affected by the heat from a stove, etc.
- Before setting up the optional kit, please confirm whether air-conditioner can receive the signal.
- Do not connect the wired remote control to the terminal for power supply.
- When connecting the wired remote controller with the indoor unit, please use the connecting cord packaged up with the wired remote controller.
- Recommended cord length of wired remote controller is 10m. Make sure to do insulate of connecting part when extended the cord.

1. REMOTE CONTROLLER CORD MODIFICATION

- Use a tool to cut off the terminal on the end of the remote controller cord, and then remove the insulation from the cut end of the cord.
- Connect the remote controller cord and connecting cord. (supplied with wired remote controller)

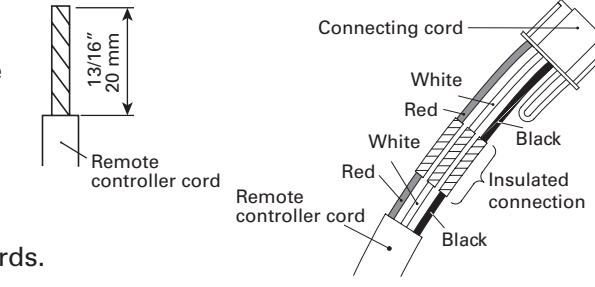

2. FRONT PANEL, CONTROL BOX COVER AND DISPLAY CASE REMOVAL

- Refer to "FRONT PANEL REMOVAL AND INSTALLATION" to remove the front panel.
- Remove the screw then remove the control box cover.
- Remove the display case and connector.

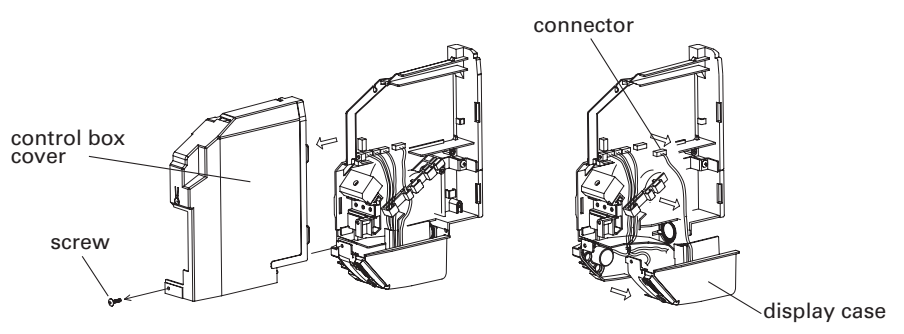

3. CONNECTING CORD TO CONTROL BOARD CONNECTOR

- Pass the cord from the hole in the back of indoor unit.
- Connect the cord to the control board connector.
- Hook the cord to the rib.

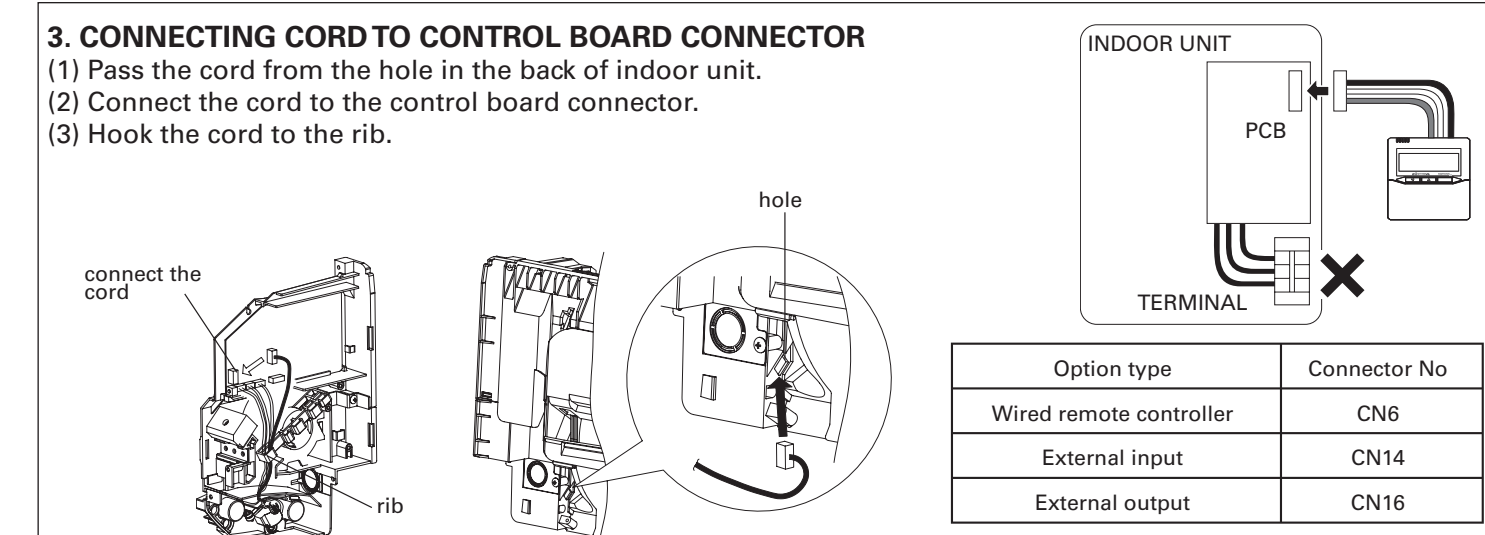

Option type	Connector No
Wired remote controller	CN6
External input	CN14
External output	CN16

- Use cord clammer and screw to fasten the cord of wired remote controller.

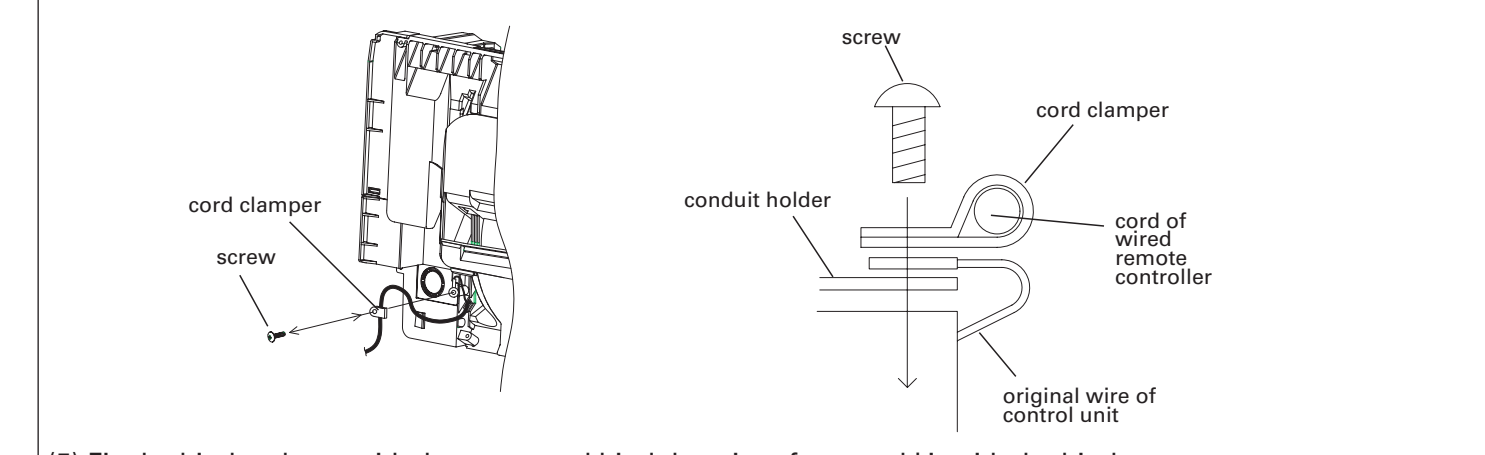

- Fix the binder clamp with the screw and bind the wire of external kit with the binder.

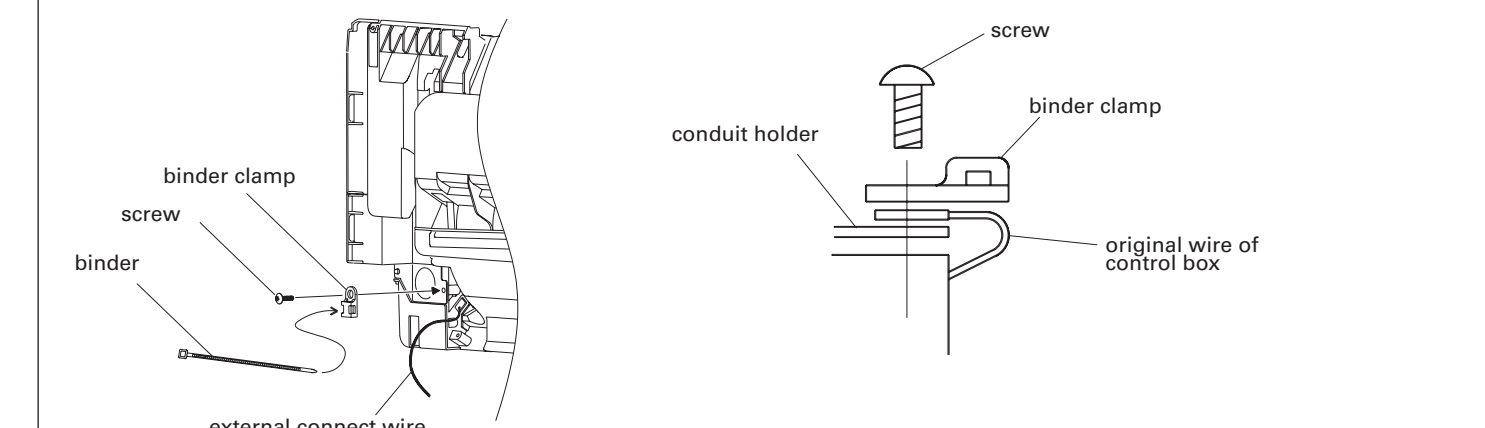

4. FRONT PANEL, CONTROL BOX COVER AND DISPLAY CASE INSTALLATION

Install front panel, control box cover and display case by the reverse procedures as stated in "2.FRONT PANEL, CONTROL BOX COVER AND DISPLAY CASE REMOVAL".