

Installation Instructions

NOTE: Read the entire instruction manual before starting the installation.

NOTE: Installer: Make sure the Owner’s Manual and Service Instructions are left with the unit after installation.

TABLE OF CONTENTS

	PAGE
SAFETY CONSIDERATIONS	1
INTRODUCTION	2
RECEIVING AND INSTALLATION	2-12
Check Equipment	2
Identify Unit	2
Inspect Shipment	2
Provide Unit Support	2
Roof Curb	2
Slab Mount	2
Ground Mount	6
Field Fabricate Ductwork	6
Provide Clearances	6
Rig and Place Unit	6
Inspection	6
Use of Rigging Bracket	6
Connect Condensate Drain	8
Install Flue Hood	8
Install Gas Piping	9
Install Duct Connections	9
Configuring Units for Downflow (Vertical)	
Discharge	10
Install Electrical Connections	11
High- Voltage Connections	11
Special Procedures for 208-V Operation	11
Control Voltage Connections	11
Heat Anticipator Setting	12
Transformer Protection	12
PRE-START-UP	12
START-UP AND TROUBLESHOOTING	13-19
Check for Refrigerant Leaks	12
Start-Up Heating & Make Adjustments	13
Check Heating Control	13
Check Gas Input	13
Adjust Gas Input	13
Check Burner Flame	14
Airflow and Temperature Rise	14
Heating Sequence of Operation	14
Limit Switches	18
Rollout Switch	14
Start-Up Cooling & Make Adjustments	18
Checking Cooling Control Operation	18
Checking & Adjusting Refrigerant Charge	18
Indoor Airflow and Airflow Adjustments	19
Cooling Sequence of Operation	19
MAINTENANCE	22-25
Air Filter	23

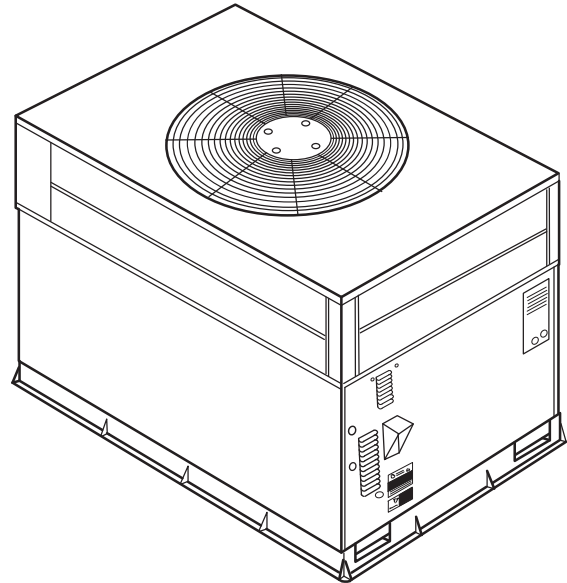

A06079

**Fig. 1 - Unit PY3P
(Low NOx Model Available)**

Indoor Blower and Motor	23
Flue Gas Passageways	23
Induced Draft (Combustion Air) Blower	23
Limit Switch	23
Burner Ignition	23
Main Burners	23
Outdoor Coil, Indoor Coil, & Condensate Drain Pan	24
Outdoor Fan	25
Electrical Controls and Wiring	25
Refrigerant Circuit	25
Indoor Airflow	25
Metering Devices	
Thermostatic Expansion Valve	25
AccuRater™ Piston	25
Liquid Line Strainer	25
TROUBLESHOOTING	25
START-UP CHECKLIST	25

SAFETY CONSIDERATIONS

Installation and servicing of this equipment can be hazardous due to mechanical and electrical components. Only trained and qualified personnel should install, repair, or service this equipment.

Untrained personnel can perform basic maintenance functions such as cleaning and replacing air filters. All other operations must be performed by trained service personnel. When working on this equipment, observe precautions in the literature, on tags, and on labels attached to or shipped with the unit and other safety precautions that may apply.

Follow all safety codes. Installation must be in compliance with local and national building codes. Wear safety glasses, protective clothing, and work gloves. Have fire extinguisher available. Read these instructions thoroughly and follow all warnings or cautions included in literature and attached to the unit.

Recognize safety information. This is the safety-alert symbol . When you see this symbol on the unit and in instructions or manuals, be alert to the potential for personal injury. Understand these signal words: DANGER, WARNING, and CAUTION. These words are used with the safety-alert symbol. DANGER identifies the most serious hazards which **will** result in severe personal injury or death. WARNING signifies hazards which **could** result in personal injury or death. CAUTION is used to identify unsafe practices which **may** result in minor personal injury or product and property damage. NOTE is used to highlight suggestions which **will** result in enhanced installation, reliability, or operation.

PY3P

 WARNING

ELECTRICAL SHOCK HAZARD

Failure to follow this warning could result in personal injury or death.

Before installing or servicing system, always turn off main power to system. There may be more than one disconnect switch. Turn off accessory heater power switch if applicable.

 WARNING

FIRE, EXPLOSION, ELECTRICAL SHOCK AND CARBON MONOXIDE POISONING HAZARD

Failure to follow this warning could result in personal injury or unit damage.

A qualified installer or agency must use only factory-authorized kits or accessories when modifying this product.

 WARNING

PERSONAL INJURY AND ENVIRONMENTAL HAZARD

Failure to relieve system pressure could result in personal injury and/or death.

1. Relieve pressure and recover all refrigerant before servicing existing equipment, and before final unit disposal. Use all service ports and open all flow-control devices, including solenoid valves.
2. Federal regulations require that you do not vent refrigerant into the atmosphere. Recover during system repair or final unit disposal.

INTRODUCTION

The PY3P unit (see Fig. 1) is a fully self-contained, combination Category I gas heating/electric cooling unit designed for outdoor installation (See Fig. 3 and 4 for unit dimensions). All unit sizes have return and discharge openings for both horizontal and downflow configurations, and are factory shipped with all downflow duct openings covered. Units may be installed either on

a rooftop, a cement slab, or directly on the ground if local codes permit (See Fig. 5 for roof curb dimensions).

Models with an N in the thirteenth position of the model number are dedicated Low NOx units designed for California installations. These models meet the California maximum oxides of nitrogen (NOx) emissions requirements of 40 nanograms/joule or less as shipped from the factory and must be installed in California Air Quality Management Districts or any other regions in North America where a Low NOx rule exists.

NOTE: Low NOx requirements apply only to natural gas installations.

RECEIVING AND INSTALLATION

Step 1 — Check Equipment

IDENTIFY UNIT

The unit model number and serial number are stamped on the unit information plate. Check this information against shipping papers.

INSPECT SHIPMENT

Inspect for shipping damage while unit is still on shipping pallet. If unit appears to be damaged or is torn loose from its anchorage, have it examined by transportation inspectors before removal. Forward claim papers directly to transportation company. Manufacturer is not responsible for any damage incurred in transit. Check all items against shipping list. Immediately notify the nearest equipment distribution office if any item is missing. To prevent loss or damage, leave all parts in original packages until installation.

Step 2 — Provide Unit Support

For hurricane tie downs, contact distributor for details and PE (Professional Engineering) Certificate if required.

ROOF CURB

Install accessory roof curb in accordance with instructions shipped with curb (See Fig. 5). Install insulation, cant strips, roofing, and flashing. Ductwork must be attached to curb.

IMPORTANT: The gasketing of the unit to the roof curb is critical for a water tight seal. Install gasketing material supplied with the roof curb. Improperly applied gasketing also can result in air leaks and poor unit performance.

Curb should be level to within 1/4 in. (6.4 mm). This is necessary for unit drain to function properly. Refer to accessory roof curb installation instructions for additional information as required.

SLAB MOUNT

Place the unit on a solid, level concrete pad that is a minimum of 4 in. (102 mm) thick with 2 in. (51 mm) above grade (See Fig. 2). The slab should extend approximately 2 in. (51 mm) beyond the casing on all 4 sides of the unit. Do not secure the unit to the slab *except* when required by local codes.

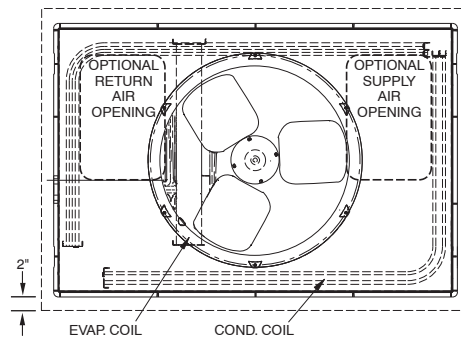

Fig. 2 - Slab Mounting Details

C99096

UNIT	ELECTRICAL CHARACTERISTICS	UNIT WT.				CENTER OF GRAVITY MM/IN			
		LB	KG	"A"	X	Y	Z		
PY3P018040	208/230-1-60	290	131.5	1041.4(41.0)	591.8(23.3)	403.9(15.9)	393.7(15.5)		
PY3P024040/060	208/230-1-60	343	156.0	940.3(37.0)	508.0(20.0)	431.8(17.0)	447.0(17.6)		
PY3P030040/060	208/230-1, 208/230-3 60 HZ	355	161.0	991.0(39.0)	508.0(20.0)	490.0(19.3)	330.0(13.0)		
PY3P036060/090	208/230-1, 208/230-3, 460-3 60HZ	360	163.0	1041.9(41.0)	533.0(21.0)	533.4(21.0)	422.0(16.6)		

REQUIRED CLEARANCES TO COMBUSTIBLE MATL.

TOP OF UNIT..... MILLIMETERS (IN)
 DUCT SIDE OF UNIT..... 355.6 (14.00)
 SIDE OPPOSITE DUCTS..... 508.0 (20.00)
 BOTTOM OF UNIT..... 914.0 (36.00)
 FLUE PANEL..... 0.00 (0.00)
 FLUE PANEL..... 914.4 (36.00)

NEC. REQUIRED CLEARANCES.

BETWEEN UNITS, POWER ENTRY SIDE..... MILLIMETERS (IN)
 UNIT AND UNGROUND, SURFACES, POWER ENTRY SIDE..... 1066.8 (42.00)
 UNIT AND BLOCK OR CONCRETE WALLS AND OTHER..... 914.0 (36.00)
 GROUNDED SURFACES, POWER ENTRY SIDE..... 1066.8 (42.00)

REQUIRED CLEARANCE FOR OPERATION AND SERVICING

FWP, COIL ACCESS SIDE..... MILLIMETERS (IN)
 POWER ENTRY SIDE..... 914.0 (36.00)
 (EXCEPT FOR NEC REQUIREMENTS)..... 1066.8 (42.00)
 UNIT TOP..... 1219.2 (48.00)
 SIDE OPPOSITE DUCTS..... 914.0 (36.00)
 DUCT PANEL..... 304.8 (12.00)*

*MINIMUM DISTANCES: IF UNIT IS PLACED LESS THAN 304.8 (12.00) FROM WALL SYSTEM, THEN SYSTEM PERFORMANCE MAYBE COMPROMISED.

DIMENSIONS IN [] ARE IN INCHES

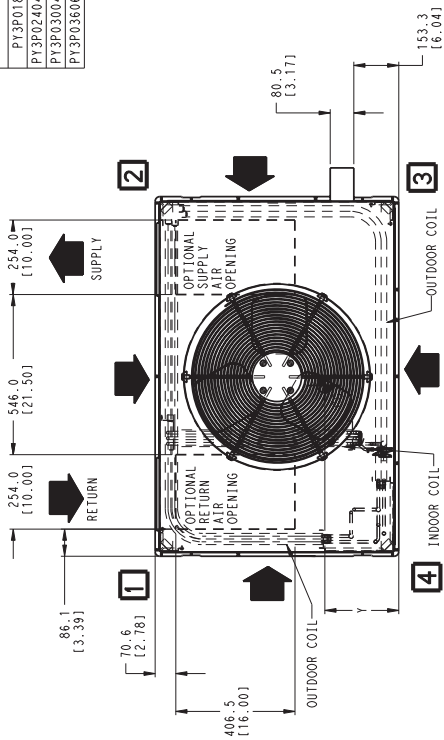

TOP VIEW

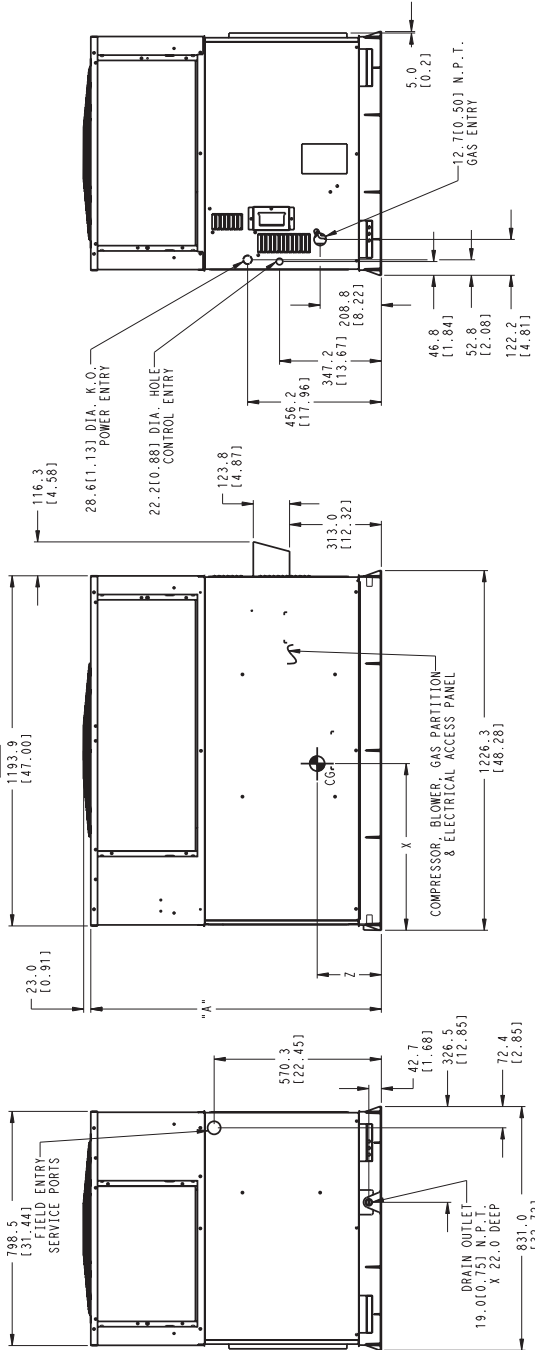

FRONT VIEW

RIGHT SIDE VIEW

REAR VIEW

48SD500036
 REV 5.0

PY3P

Fig. 3 - PY3P018-036 Unit Dimensions

UNIT	ELECTRICAL CHARACTERISTICS	UNIT WT.			UNIT HEIGHT			CENTER OF GRAVITY MM/IN			
		LB	KG	"A"	X	Y	Z				
PY3P042060/090	208/230-1, 208/230-3, 460-3 60HZ	450.0	204.1	1040.9	40.98	533.0	21.0	533.4	21.0	434.0	17.1
PY3P048090/115/130	208/230-1, 208/230-3, 460-3 60HZ	480.0	217.7	1193.0	46.98	533.0	21.0	508.0	20.0	442.0	17.4
PY3P060090/115/130	208/230-1, 208/230-3, 460-3 60HZ	484.0	219.5	1193.0	46.98	533.0	21.0	508.0	20.0	447.0	17.6

REQUIRED CLEARANCES TO COMBUSTIBLE MATL.

TOP OF UNIT.....	MILLIMETERS [IN]
DUCT SIDE OF UNIT.....	355.6 [14.00]
DUCT SIDE OF UNIT.....	350.8 [12.00]
FIELD SIDE DUCTS.....	30.0 [1.00]
BOTTOM OF UNIT.....	914.4 [36.00]
FLUE PANEL.....	914.4 [36.00]

NEC. REQUIRED CLEARANCES.

BETWEEN UNITS, POWER ENTRY SIDE.....	MILLIMETERS [IN]
UNIT AND UNITS, POWER ENTRY SIDE.....	1066.8 [42.00]
UNIT AND UNITS, POWER ENTRY SIDE.....	914.0 [36.00]
UNIT AND UNITS, POWER ENTRY SIDE.....	914.0 [36.00]
UNIT AND UNITS, POWER ENTRY SIDE.....	1066.8 [42.00]

REQUIRED CLEARANCE FOR OPERATION AND SERVICING

EVAP. COIL ACCESS SIDE.....	MILLIMETERS [IN]
POWER ENTRY SIDE.....	914.0 [36.00]
POWER ENTRY SIDE.....	1066.8 [42.00]
UNIT TOP FOR NEC REQUIREMENTS.....	1219.2 [48.00]
UNIT TOP.....	914.0 [36.00]
SIDE OPPOSITE DUCTS.....	914.0 [36.00]
DUCT OPPOSITE DUCTS.....	304.8 [12.00]

*MINIMUM DISTANCES: IF UNIT IS PLACED LESS THAN 304.8 [12.00] FROM WALL SYSTEM, THEN SYSTEM PERFORMANCE MAY BE COMPROMISED.
DIMENSIONS IN () ARE IN INCHES

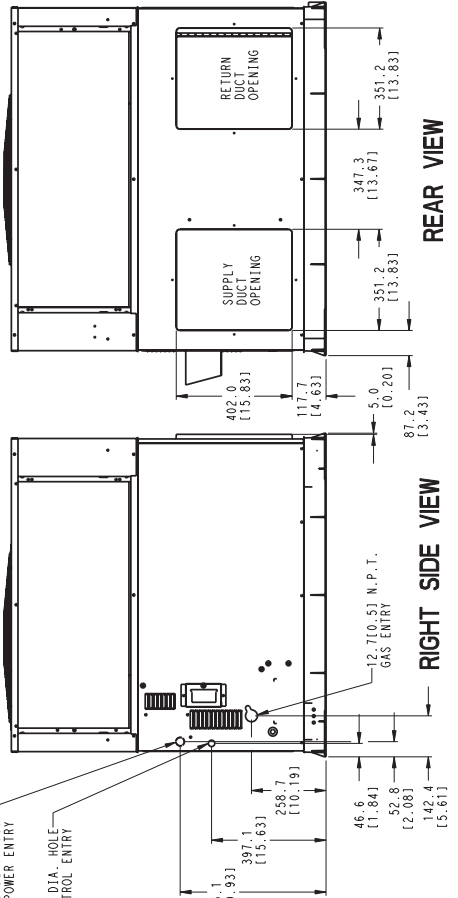
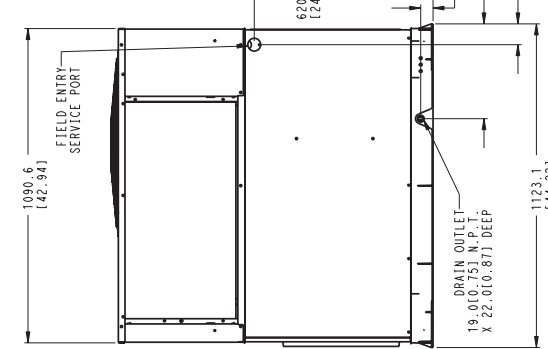
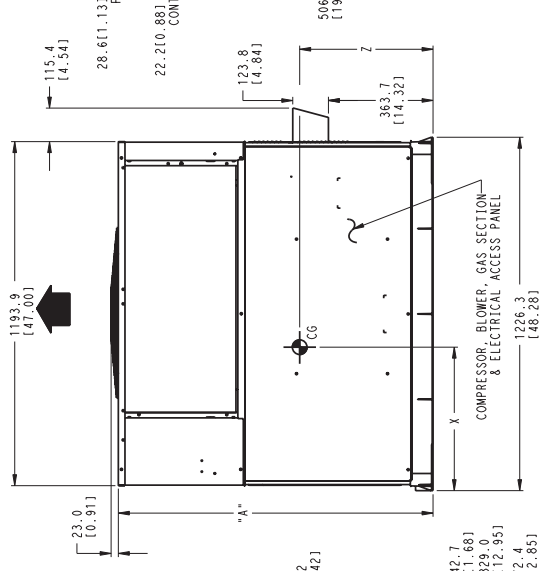
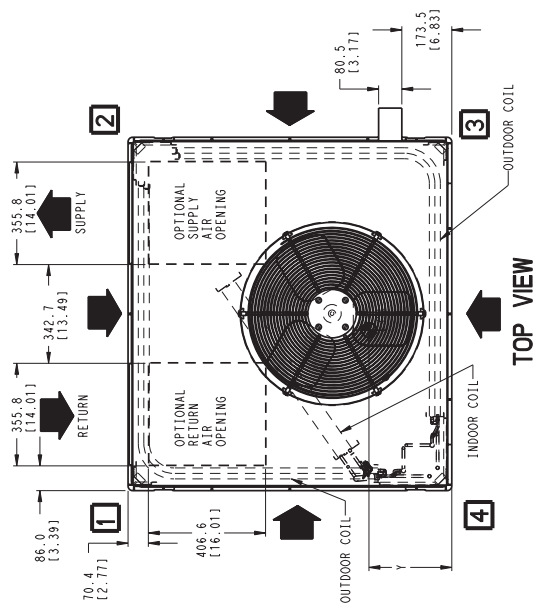

48SD500037
REV 4.0

Fig. 4 - PY3P042-060 Unit Dimensions

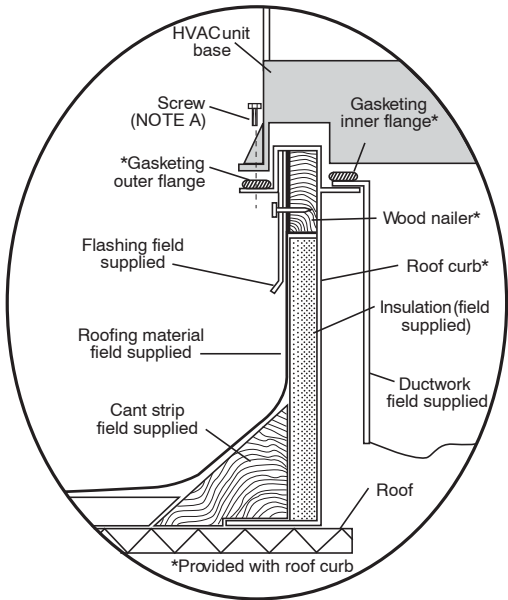

Roof Curb for Small Cabinet

Note A: When unit mounting screw is used, retainer bracket must also be used.

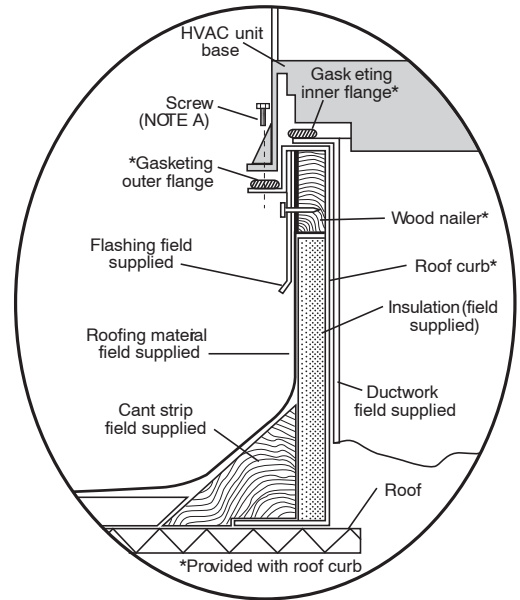

Roof Curb for Large Cabinet

Note A: When unit mounting screw is used, retainer bracket must also be used.

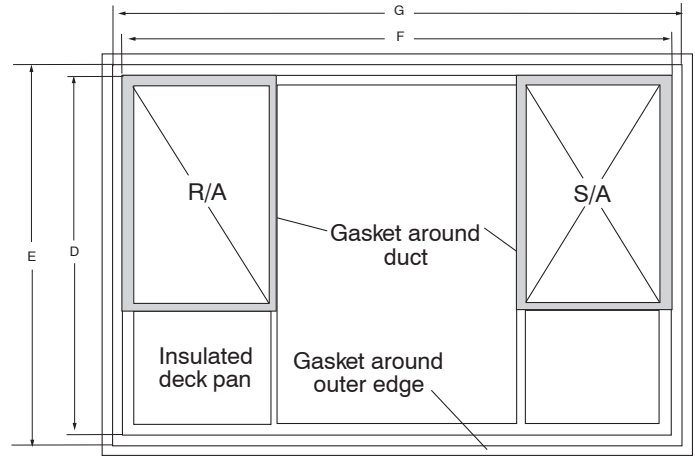
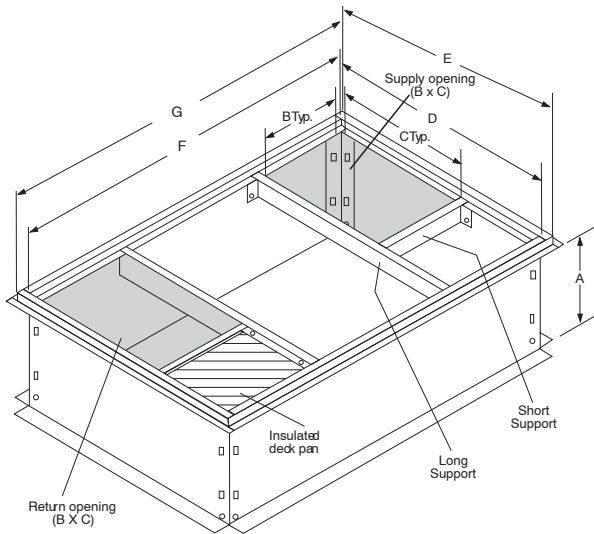

A05308

UNIT SIZE	CATALOG NUMBER	A IN. (MM)	B IN. (MM)	C IN. (MM)	D IN. (MM)	E IN. (MM)	F IN. (MM)	G IN. (MM)
PY3P018-036	CPRFCURB006A00	8 (203)	11 (279)	16-1/2 (419)	28-3/4 (730)	30-3/8 (771)	44-5/16 (1126)	45-15/16 (1167)
	CPRFCURB007A00	14 (356)	11 (279)	16-1/2 (419)	28-3/4 (730)	30-3/8 (771)	44-5/16 (1126)	45-15/16 (1167)
PY3P042-060	CPRFCURB008A00	8 (203)	16-3/16 (411)	17-3/8 (441)	40-1/4 (1022)	41-15/16 (1065)	44-7/16 (1129)	46-1/16 (1169)
	CPRFCURB009A00	14 (356)	16-3/16 (411)	17-3/8 (441)	40-1/4 (1022)	41-15/16 (1065)	44-7/16 (1129)	46-1/16 (1169)

NOTES:

1. Roof curb must be set up for unit being installed.
2. Seal strip must be applied, as required, to unit being installed.
3. Dimensions are in inches.
4. Dimension in () are in millimeters.
5. Roof curb is made of 16-gauge steel.
6. Attach ductwork to curb (flanges of duct rest on curb).
7. Insulated panels: 1-in. (25 mm) thick fiberglass 1 lb. density.
8. When unit mounting screw is used (see Note A), a retainer bracket must be used as well. This bracket must also be used when required by code for hurricane or seismic conditions. This bracket is available through Micrometl.

Fig. 5 - Roof Curb Dimensions

GROUND MOUNT

The unit may be installed either on a slab or placed directly on the ground, if local codes permit. Place the unit on level ground prepared with gravel for condensate discharge.

Step 3 — Field Fabricate Ductwork

Secure all ducts to roof curb and building structure on vertical discharge units. Do not connect ductwork to unit. For horizontal applications, unit is provided with flanges on the horizontal openings. All ductwork should be secured to the flanges. Insulate and weatherproof all external ductwork, joints, and roof openings with counter flashing and mastic in accordance with applicable codes.

Ducts passing through an unconditioned space must be insulated and covered with a vapor barrier.

If a plenum return is used on a vertical unit, the return should be ducted through the roof deck to comply with applicable fire codes.

A minimum clearance is not required around ductwork. Cabinet return-air static shall not exceed -.25 in. wc.

Step 4 — Provide Clearances

The required minimum operating and service clearances are shown in Fig. 3 and 4. Adequate combustion, ventilation and condenser air must be provided in accordance with section 9.3, Air for Combustion and Ventilation, of the National Fuel Gas Code ANSI (American National Standards Institute) Z223.1-2006 or applicable provisions of local building code. In Canada, follow sections 8 of Can/CGA (Canadian Gas Association) B149.1-05 Installation Codes or applicable provisions of local building code.

IMPORTANT: Do not restrict outdoor airflow. An air restriction at either the outdoor-air inlet or the fan discharge may be detrimental to compressor life.

The condenser fan pulls air through the condenser coil and discharges it through the top grille. Be sure that the fan discharge does not recirculate to the condenser coil. Do not locate the unit in either a corner or under an overhead obstruction. The minimum clearance under a partial overhang (such as a normal house overhang) is 48-in. (1219 mm) above the unit top. The maximum horizontal extension of a partial overhang must not exceed 48-in. (1219 mm).

Do not place the unit where water, ice, or snow from an overhang or roof will damage or flood the unit. Do not install the unit on carpeting or other combustible materials. Slab-mounted units should be at least 4 in. (102 mm) above the highest expected water and runoff levels. Do not use unit if it has been under water.

Step 5 — Rig and Place Unit

Rigging and handling of this equipment can be hazardous for many reasons due to the installation location (roofs, elevated structures, etc.).

Only trained, qualified crane operators and ground support staff should handle and install this equipment.

When working with this equipment, observe precautions in the literature, on tags, stickers, and labels attached to the equipment, and any other safety precautions that might apply.

Training for operators of the lifting equipment should include, but not be limited to, the following:

1. Application of the lifter to the load, and adjustment of the lifts to adapt to various sizes or kinds of loads.
2. Instruction in any special operation or precaution.
3. Condition of the load as it relates to operation of the lifting kit, such as balance, temperature, etc.

Follow all applicable safety codes. Wear safety shoes and work gloves.

INSPECTION

The lifting/rigging bracket is engineered and designed to be installed *only* on Small Packaged Products. This bracket is to be

used to rig/lift a Small Packaged Product onto roofs or other elevated structures.

Prior to initial use, and at monthly intervals, all rigging equipment and straps should be visually inspected for any damage, evidence of wear, structural deformation, or cracks. Particular attention should be paid to excessive wear at hoist hooking points and load support areas. Equipment or straps showing any kind of wear in these areas must not be used and should be discarded.

WARNING

UNIT FALLING HAZARD

Failure to follow this warning could result in personal injury or death.

Never stand beneath rigged units or lift over people.

WARNING

PROPERTY DAMAGE HAZARD

Failure to follow this warning could result in personal injury/death or property damage.

Rigging brackets for one unit use only. When removing a unit at the end of its useful life, use a new set of brackets.

USE OF RIGGING BRACKET

Field Installation of Rigging Bracket (if not already installed)

1. Remove unit from shipping carton. Leave top shipping skid on the unit for use as a spreader bar to prevent the rigging straps from damaging the unit. If the skid is not available, use a spreader bar of sufficient length to protect the unit from damage.
2. Remove 4 screws in unit corner posts.
3. Attach each of the 4 metal rigging brackets under the panel rain lip (See Fig. 6). Use the screws removed in step 2 above to secure the brackets to the unit.

WARNING

PROPERTY DAMAGE HAZARD

Failure to follow this warning could result in personal injury/death or property damage.

Rigging bracket **MUST** be under the rain lip to provide adequate lifting.

WARNING

PROPERTY DAMAGE HAZARD

Failure to follow this warning could result in personal injury/death or property damage.

Do not strip screws when re-securing the unit. If a screw is stripped, replace the stripped one with a larger diameter screw (included). When straps are taut, the clevis should be a minimum of 36 in. (914 mm) above the unit top cover.

Table 1 – Physical Data - Unit PY3P

UNIT SIZE PY3P	018040	024040	024060	030040	030060	036060	036090	042060	042090
NOMINAL CAPACITY (ton)	1.5	2	2	2-1/2	2-1/2	3	3	3-1/2	3-1/2
OPERATING WEIGHT lb (kg)	290 132	343 156	343 156	355 156	355 156	360 163	360 163	450 204	450 204
COMPRESSORS	Scroll								
REFRIGERANT (R-22) Quantity lb (kg)	5.3 2.4	5.9 2.7	5.9 2.7	6.0 2.7	6.0 2.7	7.2 3.3	7.2 3.3	7.8 3.5	7.8 3.5
REFRIGERANT METERING DEVICE	AccuRater								
Orifice ID in. Part Number	TXV NA EA36YD097	0.065	0.065	0.070	0.070	0.080	0.080	0.084	0.084
CONDENSER COIL Rows—Fins/in. Face Area (sq ft)	1...21 13.6	2...21 10.2	2...21 10.2	2...21 11.9	2...21 11.9	2...21 13.6	2...21 13.6	2...21 19.4	2...21 19.4
CONDENSER FAN Nominal Cfm Diameter (in.) Motor Hp (Rpm)	2200 22 1/8 (825)	2200 22 1/8 (825)	2200 22 1/8 (825)	2800 22 1/8 (825)	2800 22 1/8 (825)	3000 22 1/8 (825)	3000 22 1/8 (825)	3500 22 1/8 (825)	3500 22 1/8 (825)
EVAPORATOR COIL Rows—Fins/in. Face Area (sq ft)	3...17 3.7	3...17 3.7	3...17 3.7	3...17 3.7	3...17 3.7	4...17 3.7	4...17 3.7	3...17 4.7	3...17 4.7
EVAPORATOR BLOWER Nominal Airflow (Cfm) Size in. Size (mm) Motor Hp (RPM)	600 10x10 254x254 1/4 (825)	800 10x10 254x254 1/3 (1050)	800 10x10 254x254 1/3 (1050)	1000 10x10 254x254 1/3 (1050)	1000 10x10 254x254 1/3 (1050)	1200 10x10 254x254 1/2 (1000)	1200 10x10 254x254 1/2 (1000)	1400 11x10 279x254 1/2 (1075)	1400 11x10 279x254 1/2 (1075)
FURNACE SECTION* Burner Orifice No. (Qty—Drill Size) Natural Gas Burner Orifice No. (Qty—Drill Size) Propane	2...44 2...50	2...44 2...50	2...38 2...46	2...44 2...50	2...38 2...46	2...38 2...46	3...38 3...46	2...38 2...46	3...38 3...46
RETURN-AIR FILTERS Throwaway in.† (mm)	20x20x1 508x508x25				24x30x1 610x762x25				

PY3P

UNIT SIZE PY3P	048090	048115	048130	060090	060115	060130
NOMINAL CAPACITY (ton)	4	4	4	5	5	5
OPERATING WEIGHT lb (kg)	480 218	480 218	480 218	484 220	484 220	484 220
COMPRESSORS	Scroll					
REFRIGERANT (R-22) Quantity lb (kg)	12.4 5.6	12.4 5.6	12.4 5.6	12.0 5.4	12.0 5.4	12.0 5.4
REFRIGERANT METERING DEVICE	AccuRater					
Orifice ID (in.)	0.088	0.088	0.088	0.098	0.098	0.098
CONDENSER COIL Rows—Fins/in. Face Area (sq ft)	2...21 19.4	2...21 19.4	2...21 19.4	2...21 19.4	2...21 19.4	2...21 19.4
CONDENSER FAN Nominal Cfm Diameter in. Motor Hp (Rpm)	3500 22 1/4 (1100)	3500 22 1/4 (1100)	3500 22 1/4 (1100)	4200 22 1/4 (1100)	4200 22 1/4 (1100)	4200 22 1/4 (1100)
EVAPORATOR COIL Rows—Fins/in. Face Area (sq ft)	3...17 5.7	3...17 5.7	3...17 5.7	4...17 5.7	4...17 5.7	4...17 5.7
EVAPORATOR BLOWER Nominal Airflow (Cfm) Size in. Size (mm) Motor Hp (RPM)	1600 11x10 279x254 1/2 (1075)	1600 11x10 279x254 1/2 (1075)	1600 11x10 279x254 1/2 (1075)	1750 11x10 279x254 1 (1040)	1750 11x10 279x254 1 (1040)	1750 11x10 279x254 1 (1040)
FURNACE SECTION* Burner Orifice No. (Qty—Drill Size) Natural Gas Burner Orifice No. (Qty—Drill Size) Liquid Propane	3...38 3...46	3...33 3...42	3...31 3...41	3...38 3...46	3...33 3...42	3...31 3...41
RETURN-AIR FILTERS Throwaway in.† (mm)	24x36x1 610x914x25					

LEGEND

* Based on altitude of 0 to 2000 feet (0 to 610 m).

† Required filter sizes on shown are based on the larger of the ARI (Air Conditioning and Refrigeration Institute) rated cooling airflow or the heating airflow velocity of 300 ft/min for throwaway type or 450 ft/min for high-capacity type. Air filter pressure drop for non-standard filters must not exceed 0.08 in. wc.

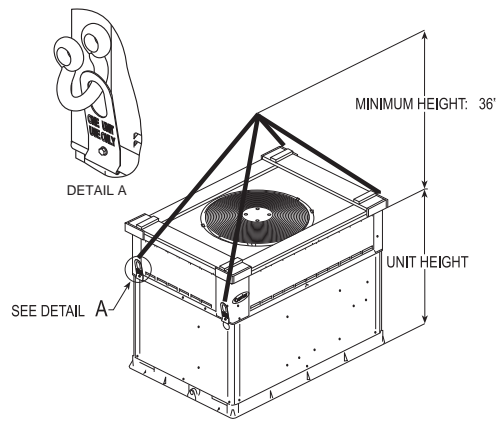
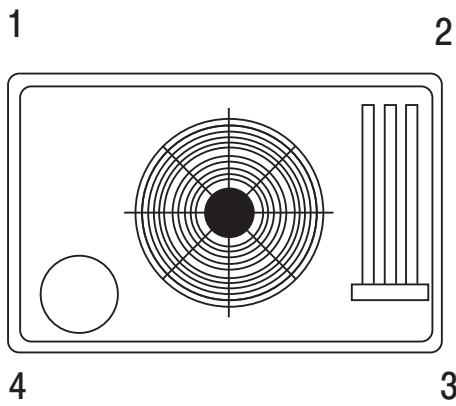

C00070B

A05161

PY3P

CORNER WEIGHTS (SMALL CABINET)									CORNER WEIGHTS (LARGE CABINET)						
Unit	018		024		030		036		Unit	042		048		060	
	lb	kg	lb	kg	lb	kg	lb	kg		lb	kg	lb	kg	lb	kg
Unit Only Weight	290	132	343	156	355	161	360	163	Unit Only Weight	450	204	480	218	484	220
Corner Weight 1	75	34	69	31	75	34	74	34	Corner Weight 1	90	41	97	44	98	45
Corner Weight 2	62	28	53	24	56	25	55	25	Corner Weight 2	72	33	74	34	75	34
Corner Weight 3	97	44	83	38	81	37	86	39	Corner Weight 3	110	50	116	53	118	54
Corner Weight 4	56	25	138	63	143	65	145	66	Corner Weight 4	178	81	193	88	193	88
Rigging Weight	309	140	353	160	365	166	370	168	Rigging Weight	465	211	495	225	499	226
Shipping Weight	344	156	383	173	395	179	400	181	Shipping Weight	510	231	540	245	544	247

Fig. 6 - PY3P Unit Corner Weights and Suggested Rigging

Rigging/Lifting of Unit

1. Bend top of brackets down approximately 30 degrees from the corner posts.
2. Attach straps of equal length to the rigging brackets at opposite ends of the unit. Be sure straps are rated to hold the weight of the unit (See Fig. 6).
3. Attach a clevis of sufficient strength in the middle of the straps. Adjust the clevis location to ensure unit is lifted level with the ground.

After the unit is placed on the roof curb or mounting pad, remove the top crating, remove corner post screws and rigging brackets, then re-install screws.

Step 6 — Connect Condensate Drain

NOTE: When installing condensate drain connection be sure to comply with local codes and restrictions.

Model PY3P disposes of condensate water through a 3/4 in. NPT fitting which exits through the base on the evaporator coil access side. See Fig. 3 & 4 for location.

Condensate water can be drained directly onto the roof in rooftop installations (where permitted) or onto a gravel apron in ground level installations. Install a field-supplied 2-in. condensate trap at the end of condensate connection to ensure proper drainage. Make sure that the outlet of the trap is at least 1 in. (25 mm) lower than the drain-pan condensate connection to prevent the pan from overflowing (See Fig. 7). Prime the trap with water. When using a gravel apron, make sure it slopes away from the unit.

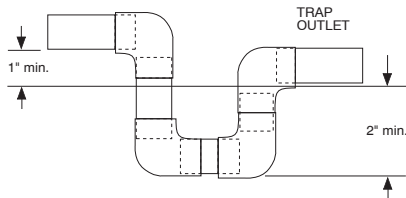

Fig. 7 - Condensate Trap

C00009

Connect a drain tube using a minimum of 3/4-in. PVC or 3/4-in. copper pipe (all field-supplied) at the outlet end of the 2-in. trap. Do not undersize the tube. Pitch the drain tube downward at a slope of at least 1-in. (25 mm) for every 10 ft (3 m) of horizontal run. Be sure to check the drain tube for leaks.

Step 7 — Install Flue Hood

The flue assembly is secured and shipped in the return air duct. Remove duct cover to locate the assembly (See Fig. 9 and 10).

NOTE: Dedicated low NOx models MUST be installed in California Air Quality Management Districts where a Low NOx rule exists.

These models meet the California maximum oxides of nitrogen (NOx) emissions requirements of 40 nanograms/joule or less as shipped from the factory.

NOTE: Low NOx requirements apply only to natural gas installations.

⚠ WARNING

CARBON MONOXIDE POISONING HAZARD

Failure to follow this warning could result in personal injury or death.

The venting system is designed to ensure proper venting. The flue hood assembly must be installed as indicated in this section of the unit installation instructions.

Install the flue hood as follows:

1. This installation must conform with local building codes and with the National Fuel Gas Code, NFPA 54/ANSI Z223.1 (in Canada, CAN/CGA B149.1, and B149.2) latest revision. Refer to Provincial and local plumbing or wastewater codes and other applicable local codes.

- Remove flue hood from shipping location (inside the return section of the blower compartment—see Fig. 9 & 10). Remove the return duct cover to locate the flue hood. Place flue hood assembly over flue panel. Orient screw holes in flue hood with holes in the flue panel.
- Secure flue hood to flue panel by inserting a single screw on the right side and the left side of the hood.

Step 8 — Install Gas Piping

The gas supply pipe enters the unit through the access hole provided. The gas connection to the unit is made to the 1/2-in. FPT gas inlet on the gas valve.

Install a gas supply line that runs to the heating section. Refer to Table 2 and the NFGC for gas pipe sizing. Do not use cast-iron pipe. It is recommended that a black iron pipe is used. Check the local utility for recommendations concerning existing lines. Size gas supply piping for 0.5 in. wc maximum pressure drop. Never use pipe smaller than the 1/2-in. FPT gas inlet on the unit gas valve.

For natural gas applications, the gas pressure at unit gas connection must not be less than 4.0 in. wc or greater than 13 in. wc while the unit is operating. For propane applications, the gas pressure must not be less than 7.0 in. wc or greater than 13 in. wc at the unit connection.

A 1/8-in. NPT plugged tapping, accessible for test gauge connection, must be installed immediately upstream of the gas supply connection to the gas valve.

When installing the gas supply line, observe local codes pertaining to gas pipe installations. Refer to the NFGC (NFPA 54/ANSI Z223.1) latest edition (in Canada, CAN/CGA B149.1).

NOTE: In the state of Massachusetts:

- Gas supply connections **MUST** be performed by a licensed plumber or gas fitter.
- When flexible connectors are used, the maximum length shall not exceed 36 inches (915 mm).
- When lever handle type manual equipment shutoff valves are used, they shall be T-handle valves.
- The use of copper tubing for gas piping is **NOT** approved by the state of Massachusetts.

In the absence of local building codes, adhere to the following pertinent recommendations:

- Avoid low spots in long runs of pipe. Grade all pipe 1/4 in. (6.4 mm) for every 15 ft (5 m) of length to prevent traps. Grade all horizontal runs downward to risers. Use risers to connect to heating section and to meter.
- Protect all segments of piping system against physical and thermal damage. Support all piping with appropriate straps, hangers, etc. Use a minimum of one hanger every 6 ft. (1.8 m). For pipe sizes larger than 1/2 in. (13 mm), follow recommendations of national codes.
- Apply joint compound (pipe dope) sparingly and only to male threads of joint when making pipe connections. Use only pipe dope that is resistant to action of liquefied petroleum gases as specified by local and/or national codes. Never use Teflon tape.
- Install sediment trap in riser leading to heating section (See Fig. 8). This drip leg functions as a trap for dirt and condensate.
- Install an accessible, external, manual main shutoff valve in gas supply pipe within 6 ft (1.8 m) of heating section.
- Install ground-joint union close to heating section between unit manual shutoff and external manual main shut-off valve.
- Pressure test all gas piping in accordance with local and national plumbing and gas codes before connecting piping to unit.

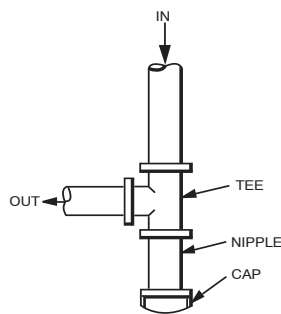

C99020

Fig. 8 - Sediment Trap

NOTE: Pressure test the gas supply system after the gas supply piping is connected to the gas valve. The supply piping must be disconnected from the gas valve during the testing of the piping systems when test pressure is in excess of 0.5 psig. Pressure test the gas supply piping system at pressures equal to or less than 0.5 psig. The unit heating section must be isolated from the gas piping system by closing the external main manual shutoff valve and slightly opening the ground-joint union.

⚠ WARNING

FIRE OR EXPLOSION HAZARD

Failure to follow this warning could result in personal injury, death and/or property damage.

–Connect gas pipe to unit using a backup wrench to avoid damaging gas controls.

–Never purge a gas line into a combustion chamber. Never test for gas leaks with an open flame. Use a commercially available soap solution made specifically for the detection of leaks to check all connections.

–Use proper length of pipe to avoid stress on gas control manifold.

–If a flexible connector is required or allowed by authority having jurisdiction, black iron pipe shall be installed at furnace gas valve and extend a minimum of 2 in. (51 mm) outside furnace casing.

–If codes allow a flexible connector, always use a new connector. do not use a connector which has previously serviced another gas appliance.

- Check for gas leaks at the field-installed and factory-installed gas lines after all piping connections have been completed. Use a commercially available soap solution made specifically for the detection of leaks (or method specified by local codes and/or regulations).

Step 9 — Install Duct Connections

The unit has duct flanges on the supply- and return-air openings on the side and bottom of the unit. For downshot applications, the ductwork connects to the roof curb (See Fig. 3 and 4 for connection sizes and locations).

Table 2 – Maximum Gas Flow Capacity*

NOMINAL IRON PIPE SIZE (IN.)	INTERNAL DIAMETER (IN.)	LENGTH OF PIPE (FT)†														
		10	20	30	40	50	60	70	80	90	100	125	150	175	200	
1/2	.622	175	120	97	82	73	66	61	57	53	50	44	40	—	—	
3/4	.824	360	250	200	170	151	138	125	118	110	103	93	84	77	72	
1	1.049	680	465	375	320	285	260	240	220	205	195	175	160	145	135	
1-1/4	1.380	1400	950	770	600	580	530	490	460	430	400	360	325	300	280	
1-1/2	1.610	2100	1460	1180	990	900	810	750	690	650	620	550	500	460	430	

*Capacity of pipe in cu ft of gas per hr for gas pressure of 0.5 psig or less. Pressure drop of 0.5–in. wc (based on a 0.60 specific gravity gas). Refer to Table, National Fire Protection Association NFPA 54.

† This length includes an ordinary number of fittings.

CONFIGURING UNITS FOR DOWNFLOW (VERTICAL) DISCHARGE

⚠ WARNING

ELECTRICAL SHOCK HAZARD

Failure to follow this warning could result in personal injury or death.

Before installing or servicing system, always turn off main power to system. There may be more than one disconnect switch.

1. Open all electrical disconnects before starting any service work.
2. Remove horizontal (metal) duct covers to access vertical (downflow) discharge duct knockouts in unit base.
3. Use a screwdriver and hammer to remove the panels in the bottom of the unit base (See Fig. 10).
4. If unit ductwork is to be attached to vertical opening flanges on the unit base (jackstand applications only), do so at this time.

⚠ CAUTION

PROPERTY DAMAGE HAZARD

Failure to follow this caution may result in property damage.

Collect ALL screws that were removed. **Do not** leave screws on rooftop as permanent damage to the roof may occur.

5. It is recommended that the base insulation around the perimeter of the vertical return-air opening be secured to the base with aluminum tape. Applicable local codes may require aluminum tape to prevent exposed fiberglass.
6. Cover both horizontal duct openings with the provided duct covers. Ensure opening is air- and watertight.
7. After completing unit conversion, perform all safety checks and power up unit.

NOTE: The design and installation of the duct system must be in accordance with the standards of the NFPA for installation of nonresidence-type air conditioning and ventilating systems, NFPA 90A or residence-type, NFPA 90B; and/or local codes and ordinances.

Adhere to the following criteria when selecting, sizing, and installing the duct system:

1. Units are shipped for horizontal duct installation (by removing duct covers).
2. Select and size ductwork, supply-air registers, and return-air grilles according to American Society of Heating, Refrigeration and Air Conditioning Engineers (ASHRAE) recommendations.

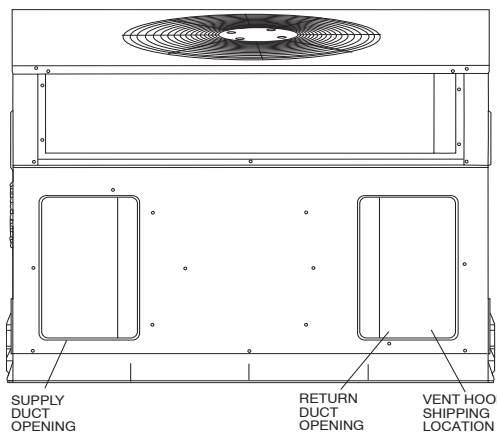

Fig. 9 - Supply and Return Duct Opening

A05143

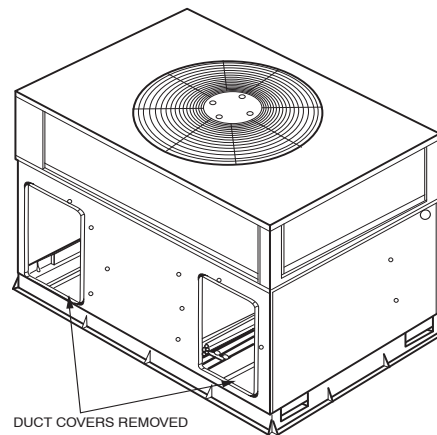

Fig. 10 - Vertical Duct Cover Removed

C99012

3. Use flexible transition between rigid ductwork and unit to prevent transmission of vibration. The transition may be screwed or bolted to duct flanges. Use suitable gaskets to ensure weather-tight and airtight seal.
4. All units must have field-supplied filters or accessory filter rack installed in the return-air side of the unit. Recommended sizes for filters are shown in Table 1.
5. Size all ductwork for maximum required airflow (either heating or cooling) for unit being installed. Avoid abrupt duct size increases or decreases or performance may be affected.
6. Adequately insulate and weatherproof all ductwork located outdoors. Insulate ducts passing through unconditioned space, and use vapor barrier in accordance with latest issue of Sheet Metal and Air Conditioning Contractors National Association (SMACNA) and Air Conditioning Contractors of America (ACCA) minimum installation standards for heating and air conditioning systems. Secure all ducts to building structure.

- Flash, weatherproof, and vibration isolate all openings in building structure in accordance with local codes and good building practices.

Step 10 — Install Electrical Connections

⚠ WARNING

ELECTRICAL SHOCK HAZARD

Failure to follow this warning could result in personal injury or death.

The unit cabinet must have an uninterrupted, unbroken electrical ground. This ground may consist of an electrical wire connected to the unit ground screw in the control compartment, or conduit approved for electrical ground when installed in accordance with NEC, ANSI/NFPA 70 American National Standards Institute/National Fire Protection Association (latest edition) (in Canada, Canadian Electrical Code CSA C22.1) and local electrical codes.

⚠ CAUTION

UNIT COMPONENT DAMAGE HAZARD

Failure to follow this caution may result in damage to the unit being installed.

- Make all electrical connections in accordance with NEC ANSI/NFPA 70 (latest edition) and local electrical codes governing such wiring. In Canada, all electrical connections must be in accordance with CSA standard C22.1 Canadian Electrical Code Part 1 and applicable local codes. Refer to unit wiring diagram.
- Use only copper conductor for connections between field-supplied electrical disconnect switch and unit. **DO NOT USE ALUMINUM WIRE.**
- Be sure that high-voltage power to unit is within operating voltage range indicated on unit rating plate. On 3-phase units, ensure phases are balanced within 2 percent. Consult local power company for correction of improper voltage and/or phase imbalance.
- Insulate low-voltage wires for highest voltage contained within conduit when low-voltage control wires are in same conduit as high-voltage wires.
- Do not damage internal components when drilling through any panel to mount electrical hardware, conduit, etc.

HIGH-VOLTAGE CONNECTIONS

When routing power leads into unit, use only copper wire between disconnect and unit. The high voltage leads should be in a conduit until they enter the duct panel; conduit termination at the duct panel must be watertight.

The unit must have a separate electrical service with a field-supplied, waterproof disconnect switch mounted at, or within sight from, the unit. Refer to the unit rating plate, NEC and local codes for maximum fuse/circuit breaker size and minimum circuit amps (ampacity) for wire sizing.

The field-supplied disconnect switch box may be mounted on the unit over the high-voltage inlet hole when the standard power and low-voltage entry points are used (See Fig. 3 and 4 for acceptable location).

See unit wiring label and Fig. 11 for reference when making high voltage connections. Proceed as follows to complete the high-voltage connections to the unit.

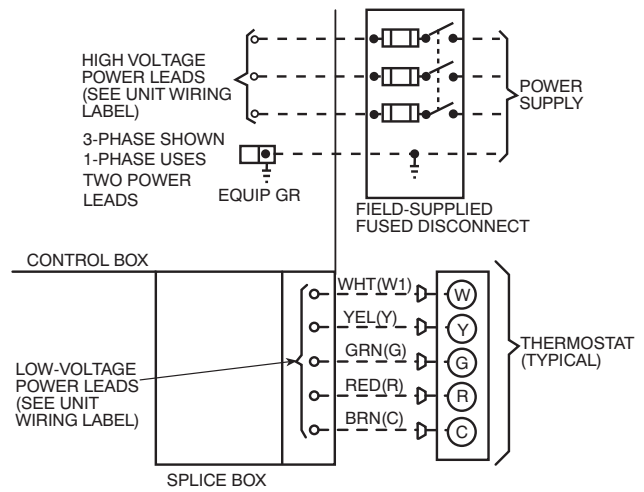

A08205

Fig. 11 - High- and Control-Voltage Connections

Single phase units:

- Run the high-voltage (L1, L2) and ground lead into the control box.
- Connect ground lead to chassis ground connection.
- Locate the black and yellow wires connected to the line side of the contactor.
- Connect field L1 to black wire connected to 11 terminal of the compressor contactor.
- Connect field wire L2 to yellow wire connected to 23 terminal of the compressor contactor.

Three-phase units:

- Run the high-voltage (L1, L2, L3) and ground lead into the control box.
- Connect ground lead to chassis ground connection.
- Locate the black and yellow wires connected to the line side of the contactor, and blue wire from compressor.
- Connect field L1 to black wire on connected to 11 terminal of the compressor contactor.
- Connect field wire L3 to yellow wire connected to 13 terminal of the compressor contactor.
- Connect field wire L2 to blue wire from compressor.

SPECIAL PROCEDURES FOR 208-V OPERATION

⚠ WARNING

ELECTRICAL SHOCK HAZARD

Failure to follow this warning could result in personal injury or death.

Before making any wiring changes, **make sure** the gas supply is switched off first. *Then* switch off the power supply to the unit and install lockout tag.

CONTROL VOLTAGE CONNECTIONS

Do not use any type of power-stealing thermostat. Unit control problems may result.

Use no. 18 American Wire Gage (AWG) color-coded, insulated (35°C minimum) wires to make the control voltage connections between the thermostat and the unit. If the thermostat is located more than 100 ft from the unit (as measured along the control voltage wires), use no. 16 AWG color-coded, insulated (35°C minimum) wires.

PY3P

Standard Connection

Locate the low voltage thermostat leads in 24 volt splice box. See Fig. 11 for connection diagram. Run the low-voltage leads from the thermostat, through the control wiring inlet hole grommet (Fig. 2 and 3), and into the low-voltage splice box. Provide a drip loop before running wires through panel. Secure and stain relief all wires so that they do not interfere with operation of unit.

HEAT ANTICIPATOR SETTING

See thermostat instructions for anticipator and cycle rate setup details.

NOTE: For thermostat selection purposes, use 0.18 amp for the approximate required setting. Failure to make a proper heat anticipator adjustment will result in improper operation, discomfort to the occupants of the conditioned space, and inefficient energy utilization; however, the required setting may be changed slightly to provide a greater degree of comfort for a particular installation.

TRANSFORMER PROTECTION

The transformer is of the energy-limiting type. It is set to withstand a 30-sec. overload or shorted secondary condition.

PRE-START-UP

⚠ WARNING

FIRE, EXPLOSION, ELECTRICAL SHOCK HAZARD

Failure to follow this warning could result in personal injury or death.

1. Follow recognized safety practices and wear protective goggles when checking or servicing refrigerant system.
2. Do not operate compressor or provide any electric power to unit unless compressor terminal cover is in place and secured.
3. Do not remove compressor terminal cover until all electrical sources are disconnected and tagged.
4. Relieve and recover all refrigerant from system before touching or disturbing anything inside terminal box if refrigerant leak is suspected around compressor terminals.
5. Never attempt to repair soldered connection while refrigerant system is under pressure.
6. Do not use torch to remove any component. System contains oil and refrigerant under pressure.
To remove a component, wear protective goggles and proceed as follows:
 - a. Shut off electrical power to unit and install lockout tag.
 - b. Relieve and reclaim all refrigerant from system using both high- and low-pressure ports.
 - c. Cut component connecting tubing with tubing cutter and remove component from unit.
 - d. Carefully unsweat remaining tubing stubs when necessary. Oil can ignite when exposed to torch flame.

Use the Start-Up Checklist supplied at the end of this book and proceed as follows to inspect and prepare the unit for initial start-up:

1. Remove access panel.
2. Read and follow instructions on all DANGER, WARNING, CAUTION, and INFORMATION labels attached to, or shipped with unit.
3. Make the following inspections:

- a. Inspect for shipping and handling damage, such as broken lines, loose parts, disconnected wires, etc.
- b. Inspect for oil at all refrigerant tubing connections and on unit base. Detecting oil generally indicates a refrigerant leak.
- c. Leak-test all refrigerant tubing connections using electronic leak detector, or liquid-soap solution. If a refrigerant leak is detected, see following Check for Refrigerant Leaks section.
- d. Inspect all field- and factory-wiring connections. Be sure that connections are completed and tight.
- e. Ensure wires do not touch refrigerant tubing or sharp sheet metal edges.
- f. Inspect coil fins. If damaged during shipping and handling, carefully straighten fins with a fin comb.

⚠ WARNING

FIRE, EXPLOSION HAZARD

Failure to follow this warning could result in personal injury, death or property damage.

Do not purge gas supply into the combustion chamber. Do not use a match or other open flame to check for gas leaks.

4. Verify the following conditions:
 - a. Make sure gas line is free of air. Before lighting the unit for the first time, perform the following with the gas valve in the OFF position:

NOTE: If the gas supply pipe was not purged before connecting the unit, it will be full of air. It is recommended that the ground joint union be loosened, and the supply line be allowed to purge until the odor of gas is detected. Never purge gas lines into a combustion chamber. Immediately upon detection of gas odor, retighten the union. Allow 5 minutes to elapse, then light unit.

- b. Make sure that condenser-fan blade is correctly positioned in fan orifice. As a general rule, the top 1/3 of condenser-fan blade should be within fan orifice venturi.
- c. Ensure fan hub is positioned correctly with respect to motor housing.
- d. Make sure that air filter(s) is in place.
- e. Make sure that condensate drain trap is filled with water to ensure proper drainage.
- f. Make sure that all tools and miscellaneous loose parts have been removed.

START-UP

Step 1 — CHECK FOR REFRIGERANT LEAKS

Proceed as follows to locate and repair a refrigerant leak and to charge the unit:

1. Locate leak and make sure that refrigerant system pressure has been relieved and reclaimed from both high- and low-pressure ports.
2. Repair leak following accepted practices.

NOTE: Install a filter drier whenever the system has been opened for repair.

3. Add a small charge of R-22 refrigerant vapor to system and leak-test unit.
4. Recover refrigerant from refrigerant system and evacuate to 500 microns if no additional leaks are found.
5. Charge unit with R-22 refrigerant, using a volumetric charging cylinder or accurate scale. Refer to unit rating plate for required charge. Be sure to add extra refrigerant to compensate for internal volume of filter drier.

Step 2 — START-UP HEATING AND MAKE ADJUSTMENTS

Complete the required procedures given in the Pre-Start-Up section before starting the unit. Do not jumper any safety devices when operating the unit. Make sure that burner orifices are properly aligned. Unstable operation may occur when the burner orifices in the manifold are misaligned.

Follow the lighting instructions on the heating section operation label (located inside the burner or blower access door) to start the heating section.

NOTE: Make sure that gas supply has been purged, and that all gas piping has been checked for leaks.

CHECK HEATING CONTROL

Start and check the unit for proper heating control operation as follows (see furnace lighting instructions located inside burner or blower access panel):

1. Place room thermostat SYSTEM switch in the HEAT position and the fan switch is placed in AUTO position.
2. Set the heating temperature control of the thermostat above room temperature.
3. The induced-draft motor will start.
4. After a call for heating, the main burner should light within 5 sec. If the burners do not light, there is a 22-sec. delay before another 5-sec. try. If the burners still do not light, this sequence is repeated. If the burners do not light within 15 minutes from the initial call for heat, there is a lockout. To reset the control, break the 24-v power to W.
5. The evaporator fan will turn on 45 sec. after the flame has been established. The evaporator fan will turn off 45 sec. after the thermostat has been satisfied.

CHECK GAS INPUT

Check gas input and manifold pressure after unit start-up (See Table 3). If adjustment is required proceed as follows:

- The rated gas inputs shown in Table 3 are for altitudes from sea level to 2000 ft (610 m) above sea level. These inputs are based on natural gas with a heating value of 1050 Btu/ft³ at 0.65 specific gravity, or propane gas with a heating value of 2500 Btu/ft³ at 1.5 specific gravity.
- For elevations above 2000 ft (610 m), reduce input 4% for each 1000 ft (305 m) above sea level. For example at 2001 ft (610 m) a 12% total derate is required.
- When the gas supply being used has a different heating value or

specific gravity, refer to national and local codes, or contact your distributor to determine the required orifice size.

⚠ CAUTION

UNIT DAMAGE HAZARD

Failure to follow this caution may result in reduced unit and/or component life.

Do Not redrill an orifice. Improper drilling (burrs, out-of-round holes, etc.) can cause excessive burner noise and misdirection of burner flame. If orifice hole appears damaged or it is suspected to have been redrilled, check orifice hole with a numbered drill bit of correct size.

ADJUST GAS INPUT

The gas input to the unit is determined by measuring the gas flow at the meter or by measuring the manifold pressure. Measuring the gas flow at the meter is recommended for natural gas units. The manifold pressure must be measured to determine the input of propane gas units.

Measure Gas Flow (Natural Gas Units)

Minor adjustment to the gas flow can be made by changing the manifold pressure. The manifold pressure must be maintained between 3.4 and 3.6 in. wc.

If larger adjustments are required, change main burner orifices following the recommendations of national and local codes.

NOTE: All other appliances that use the same meter must be turned off when gas flow is measured at the meter.

Proceed as follows:

1. Turn off gas supply to unit.
2. Remove pipe plug on manifold (See Fig. 12) and connect manometer. Turn on gas supply to unit.
3. Record number of seconds for gas meter test dial to make one revolution.
4. Divide number of seconds in Step 3 into 3600 (number of seconds in one hr).
5. Multiply result of Step 4 by the number of cubic feet (cu ft) shown for one revolution of test dial to obtain cubic feet (cu ft) of gas flow per hour.
6. Multiply result of Step 5 by Btu heating value of gas to obtain total measured input in Btuh. Compare this value with heating input shown in Table 3 (Consult the local gas supplier if the heating value of gas is not known).

EXAMPLE: Assume that the size of test dial is 1 cu ft, one revolution takes 32 sec, and the heating value of the gas is 1050 Btu/ft³. Proceed as follows:

1. 32 sec. to complete one revolution.
2. $3600 \div 32 = 112.5$.
3. $112.5 \times 1 = 112.5$ ft³ of gas flow/hr.
4. $112.5 \times 1050 = 118,125$ Btuh input.

If the desired gas input is 115,000 Btuh, only a minor change in the manifold pressure is required.

Observe manifold pressure and proceed as follows to adjust gas input:

1. Remove cover screw over regulator adjustment screw on gas valve.
2. Turn regulator adjustment screw clockwise to increase gas input, or turn regulator adjustment screw counterclockwise to decrease input. Manifold pressure must be between 3.4 and 3.6 in. wc.

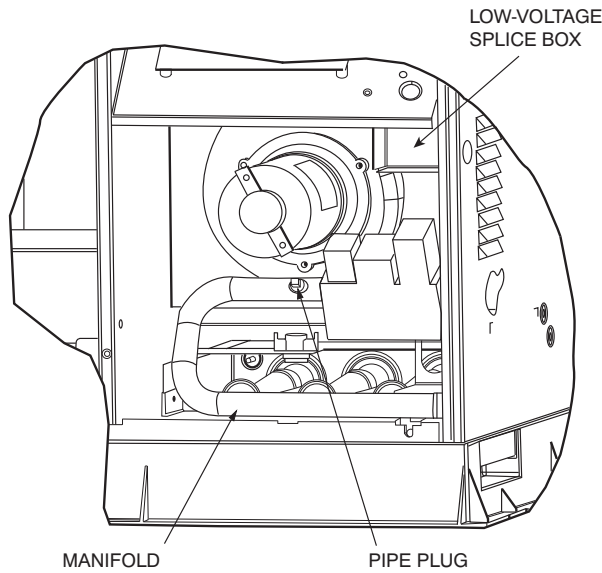
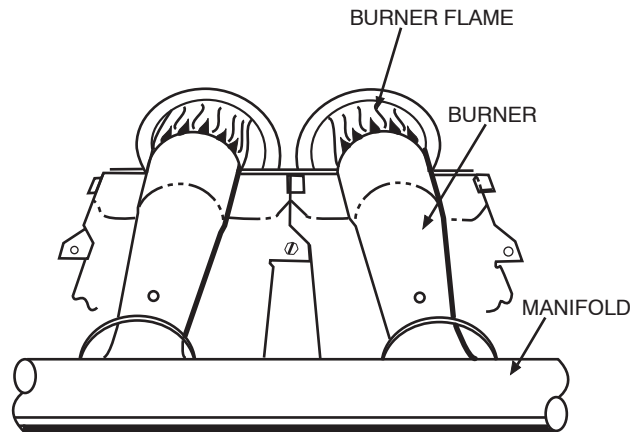

Fig. 12 - Burner Assembly

A07568



C99021

Fig. 13 - Monopoly Burner

AIRFLOW AND TEMPERATURE RISE

The heating section for each size unit is designed and approved for heating operation within the temperature-rise range stamped on the unit rating plate.

Table 8 shows the approved temperature rise range for each heating input, and the air delivery cfm at various temperature rises. The heating operation airflow must produce a temperature rise that falls within the approved range.

Refer to Indoor Airflow and Airflow Adjustments section to adjust heating airflow when required.

HEATING SEQUENCE OF OPERATION

(See Fig. 14-16 and unit wiring label.)

On a call for heating, terminal W of the thermostat is energized, starting the induced-draft motor. When the hall-effect sensor on the induced-draft motor senses that it has reached the required speed, the burner sequence begins. This function is performed by the integrated gas control (IGC). The indoor (evaporator)-fan motor is energized 45 sec after flame is established. When the thermostat is satisfied and W is de-energized, the burners stop firing and the indoor (evaporator) fan motor shuts off after a 45-sec time-off delay.

Please note that the ignition control board (IGC) has the capability to automatically reduce the indoor fan motor on and off delays in the event of high duct static and/or partially-clogged filter. An adjustment of fan delays by the ignition control board is indicated by a flash code "1" on the LED on the IGC.

An LED (light-emitting diode) indicator is provided on the control board to monitor operation. The control board is located by removing the burner access panel. During normal operation, the LED is continuously on (See Table 4 for status codes).

LIMIT SWITCHES

Normally closed limit switch (LS) completes the control circuit. Should the leaving-air temperature rise above the maximum allowable temperature, the limit switch opens and the control circuit "breaks." Any interruption in the control circuit instantly closes the gas valve and stops gas flow to the burners and pilot. The blower motor continues to run until LS resets.

When the air temperature at the limit switch drops to the low-temperature setting of the limit switch, the switch closes and completes the control circuit. The direct-spark ignition system cycles and the unit returns to normal heating operation.

⚠ WARNING

FIRE AND UNIT DAMAGE HAZARD

Failure to follow this warning could result in personal injury or death and/or property damage.

Unsafe operation of the unit may result if manifold pressure is outside this range.

3. Replace cover screw cap on gas valve.
4. Turn off gas supply to unit. Remove manometer from pressure tap and replace pipe plug on gas valve. Turn on gas to unit and check for leaks.

Measure Manifold Pressure (Propane Units)

The main burner orifices on a propane gas unit are sized for the unit rated input when the manifold pressure reading matches the level specified in Table 3.

Proceed as follows to adjust gas input on a propane gas unit:

1. Turn off gas to unit.
2. Remove pipe plug on manifold and connect manometer (See Fig. 12).
3. Turn on gas to unit.
4. Remove cover screw over regulator adjustment screw on gas valve.
5. Adjust regulator adjustment screw to the correct manifold pressure, as specified in Table 3. Turn adjusting screw clockwise to increase manifold pressure, or turn adjusting screw counterclockwise to decrease manifold pressure.
6. Replace cover screw.
7. Turn off gas to unit. Remove manometer from pressure tap. Replace pipe plug on gas valve, then turn on gas to unit. Check for leaks.

CHECK BURNER FLAME

With burner access panel removed, observe the unit heating operation. Watch the burner flames to see if they are light blue and soft in appearance, and that the flames are approximately the same for each burner. Propane will have blue flame (See Fig. 13). Refer to the Maintenance section for information on burner removal.

CONNECTION WIRING DIAGRAM

DANGER: ELECTRICAL SHOCK HAZARD DISCONNECT POWER BEFORE SERVICING

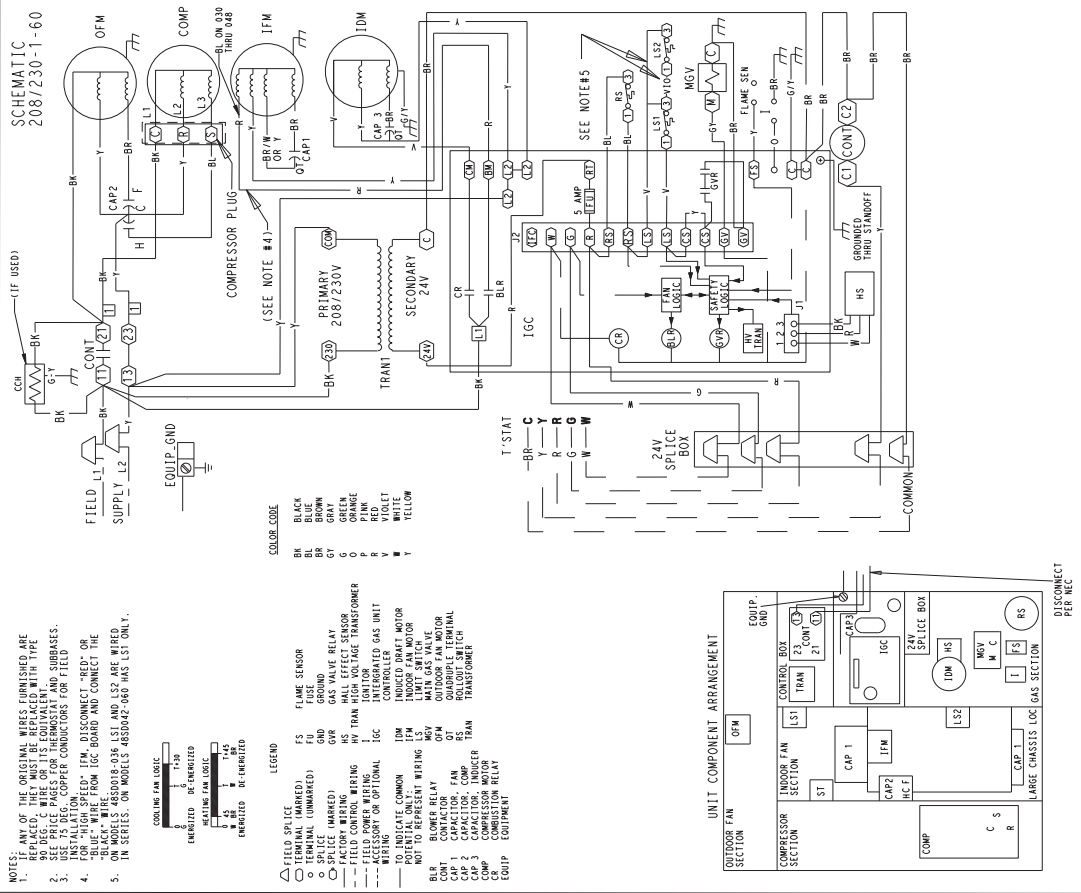

LADDER WIRING DIAGRAM

DANGER: ELECTRICAL SHOCK HAZARD DISCONNECT POWER BEFORE SERVICING

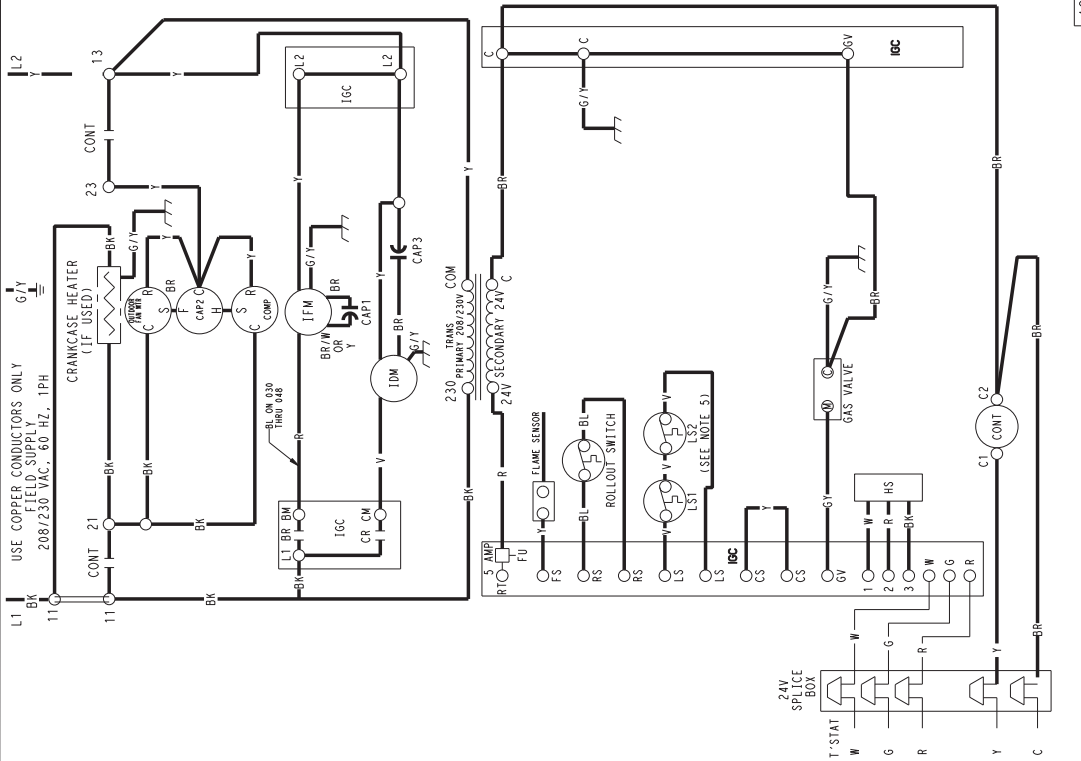
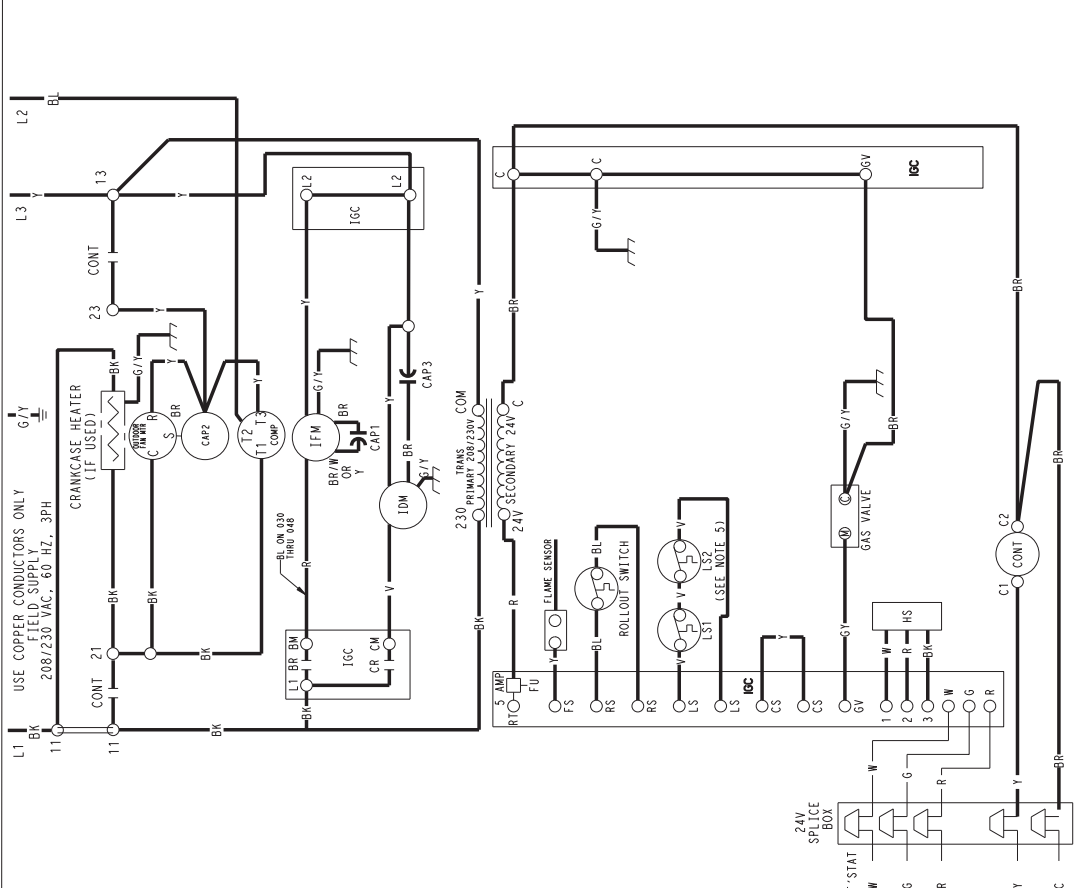

Fig. 14 - 208/230-1-60 Wiring Diagram

LADDER WIRING DIAGRAM

DANGER: ELECTRICAL SHOCK HAZARD DISCONNECT POWER BEFORE SERVICING



48SD500051 4.0

CONNECTION WIRING DIAGRAM

DANGER: ELECTRICAL SHOCK HAZARD DISCONNECT POWER BEFORE SERVICING

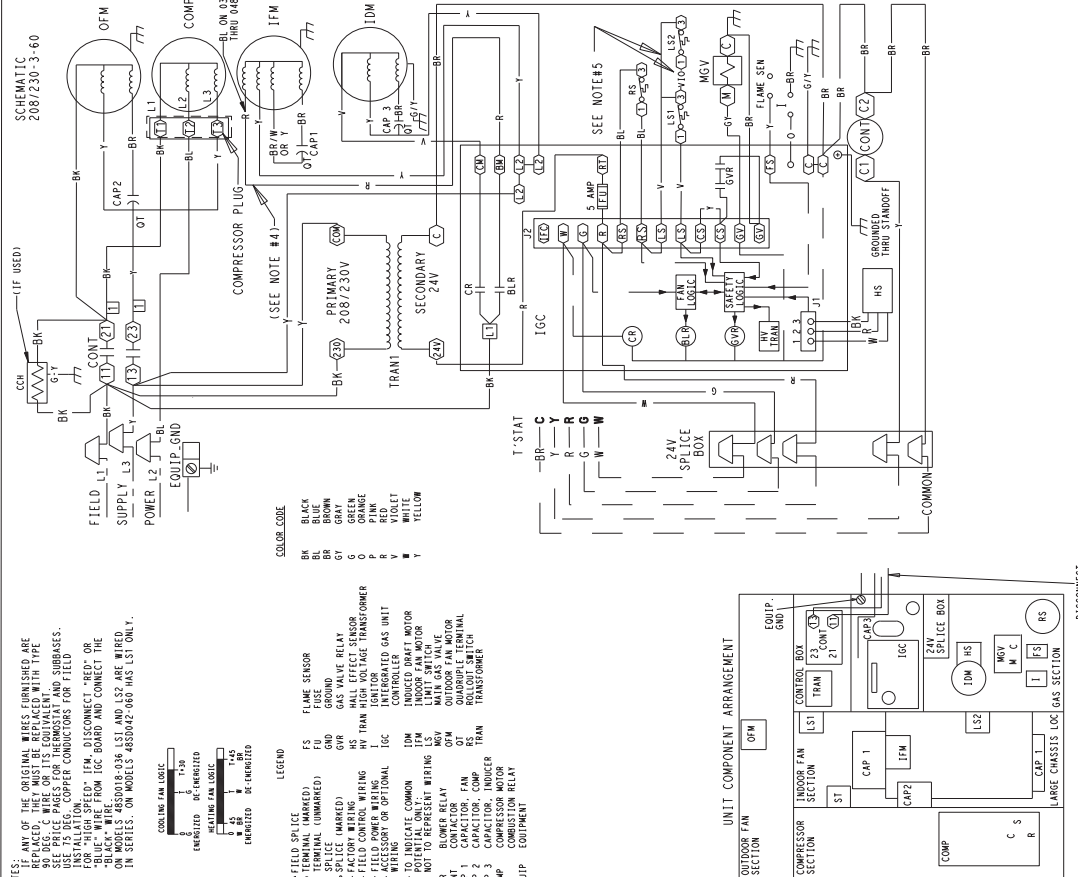

- NOTES:
- IF ANY OF THE ORIGINAL WIRES FURNISHED ARE 90 DEG C WIRE OR ITS EQUIVALENT WITH THE TYPE OF WIRE, THE WIRE MUST BE REPLACED WITH THE SAME TYPE.
 - SEE PRICE PAGES FOR THERMOSTAT AND SUBBASES.
 - INSTALLATION: USE COPPER CONDUCTORS FOR FIELD WIRING.
 - FOR "HIGH SPEED" IFM, DISCONNECT WIRE OR "BLACK" WIRE, FROM LOC BOARD AND CONNECT THE WIRE TO THE IFM.
 - ON MODELS 48SD03039, 48SD03042 AND 48SD03045 USE FIELD WIRING, ON MODELS 48SD03046 AND 48SD03047 USE ONLY.

COLOR CODE

BK	BLACK
BL	BLUE
BR	BROWN
BU	BROWN
OR	ORANGE
GR	GREEN
RD	RED
VT	VIOLET
WH	WHITE
Y	YELLOW

- LEGEND
- FIELD SPICE (USED)
 - TERMINAL (UNMARKED)
 - SPICE (MARKED)
 - FACTORY WIRING
 - FIELD CONTROL WIRING
 - ACCESSORY OR OPTIONAL WIRING
 - TO INDICATE COMMON
 - BLR BLOWER RELAY
 - CR CRANKCASE HEATER
 - CAP 1 CAPACITOR, COMP
 - CAP 2 CAPACITOR, COMP
 - CAP 3 CAPACITOR, INDUCER
 - COMP COMPRESSOR
 - CR COMBUSTION RELAY
 - EQUIP EQUIPMENT
 - FLAME SENSOR
 - FUSE
 - GRD GROUND
 - HS HIGH VOLTAGE RELAY
 - HW TRANS HIGH VOLTAGE TRANSFORMER
 - IGNER IGNITION
 - IGC INTEGRATED GAS UNIT CONTROLLER
 - IDM INDUCED DRAFT MOTOR
 - IFM INDOOR FAN MOTOR
 - LS LIMIT SWITCH
 - LS1 OUTDOOR FAN MOTOR
 - LS2 OUTDOOR FAN MOTOR
 - LS3 OUTDOOR FAN MOTOR
 - LS4 OUTDOOR FAN MOTOR
 - LS5 OUTDOOR FAN MOTOR
 - LS6 OUTDOOR FAN MOTOR
 - LS7 OUTDOOR FAN MOTOR
 - LS8 OUTDOOR FAN MOTOR
 - LS9 OUTDOOR FAN MOTOR
 - LS10 OUTDOOR FAN MOTOR
 - LS11 OUTDOOR FAN MOTOR
 - LS12 OUTDOOR FAN MOTOR
 - LS13 OUTDOOR FAN MOTOR
 - LS14 OUTDOOR FAN MOTOR
 - LS15 OUTDOOR FAN MOTOR
 - LS16 OUTDOOR FAN MOTOR
 - LS17 OUTDOOR FAN MOTOR
 - LS18 OUTDOOR FAN MOTOR
 - LS19 OUTDOOR FAN MOTOR
 - LS20 OUTDOOR FAN MOTOR
 - LS21 OUTDOOR FAN MOTOR
 - LS22 OUTDOOR FAN MOTOR
 - LS23 OUTDOOR FAN MOTOR
 - LS24 OUTDOOR FAN MOTOR
 - LS25 OUTDOOR FAN MOTOR
 - LS26 OUTDOOR FAN MOTOR
 - LS27 OUTDOOR FAN MOTOR
 - LS28 OUTDOOR FAN MOTOR
 - LS29 OUTDOOR FAN MOTOR
 - LS30 OUTDOOR FAN MOTOR
 - LS31 OUTDOOR FAN MOTOR
 - LS32 OUTDOOR FAN MOTOR
 - LS33 OUTDOOR FAN MOTOR
 - LS34 OUTDOOR FAN MOTOR
 - LS35 OUTDOOR FAN MOTOR
 - LS36 OUTDOOR FAN MOTOR
 - LS37 OUTDOOR FAN MOTOR
 - LS38 OUTDOOR FAN MOTOR
 - LS39 OUTDOOR FAN MOTOR
 - LS40 OUTDOOR FAN MOTOR
 - LS41 OUTDOOR FAN MOTOR
 - LS42 OUTDOOR FAN MOTOR
 - LS43 OUTDOOR FAN MOTOR
 - LS44 OUTDOOR FAN MOTOR
 - LS45 OUTDOOR FAN MOTOR
 - LS46 OUTDOOR FAN MOTOR
 - LS47 OUTDOOR FAN MOTOR
 - LS48 OUTDOOR FAN MOTOR
 - LS49 OUTDOOR FAN MOTOR
 - LS50 OUTDOOR FAN MOTOR
 - LS51 OUTDOOR FAN MOTOR
 - LS52 OUTDOOR FAN MOTOR
 - LS53 OUTDOOR FAN MOTOR
 - LS54 OUTDOOR FAN MOTOR
 - LS55 OUTDOOR FAN MOTOR
 - LS56 OUTDOOR FAN MOTOR
 - LS57 OUTDOOR FAN MOTOR
 - LS58 OUTDOOR FAN MOTOR
 - LS59 OUTDOOR FAN MOTOR
 - LS60 OUTDOOR FAN MOTOR
 - LS61 OUTDOOR FAN MOTOR
 - LS62 OUTDOOR FAN MOTOR
 - LS63 OUTDOOR FAN MOTOR
 - LS64 OUTDOOR FAN MOTOR
 - LS65 OUTDOOR FAN MOTOR
 - LS66 OUTDOOR FAN MOTOR
 - LS67 OUTDOOR FAN MOTOR
 - LS68 OUTDOOR FAN MOTOR
 - LS69 OUTDOOR FAN MOTOR
 - LS70 OUTDOOR FAN MOTOR
 - LS71 OUTDOOR FAN MOTOR
 - LS72 OUTDOOR FAN MOTOR
 - LS73 OUTDOOR FAN MOTOR
 - LS74 OUTDOOR FAN MOTOR
 - LS75 OUTDOOR FAN MOTOR
 - LS76 OUTDOOR FAN MOTOR
 - LS77 OUTDOOR FAN MOTOR
 - LS78 OUTDOOR FAN MOTOR
 - LS79 OUTDOOR FAN MOTOR
 - LS80 OUTDOOR FAN MOTOR
 - LS81 OUTDOOR FAN MOTOR
 - LS82 OUTDOOR FAN MOTOR
 - LS83 OUTDOOR FAN MOTOR
 - LS84 OUTDOOR FAN MOTOR
 - LS85 OUTDOOR FAN MOTOR
 - LS86 OUTDOOR FAN MOTOR
 - LS87 OUTDOOR FAN MOTOR
 - LS88 OUTDOOR FAN MOTOR
 - LS89 OUTDOOR FAN MOTOR
 - LS90 OUTDOOR FAN MOTOR
 - LS91 OUTDOOR FAN MOTOR
 - LS92 OUTDOOR FAN MOTOR
 - LS93 OUTDOOR FAN MOTOR
 - LS94 OUTDOOR FAN MOTOR
 - LS95 OUTDOOR FAN MOTOR
 - LS96 OUTDOOR FAN MOTOR
 - LS97 OUTDOOR FAN MOTOR
 - LS98 OUTDOOR FAN MOTOR
 - LS99 OUTDOOR FAN MOTOR
 - LS100 OUTDOOR FAN MOTOR

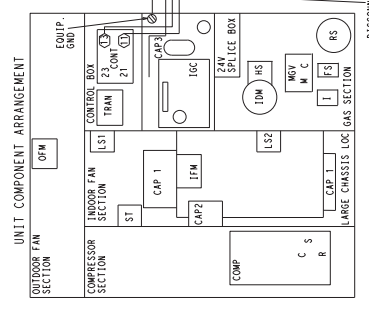
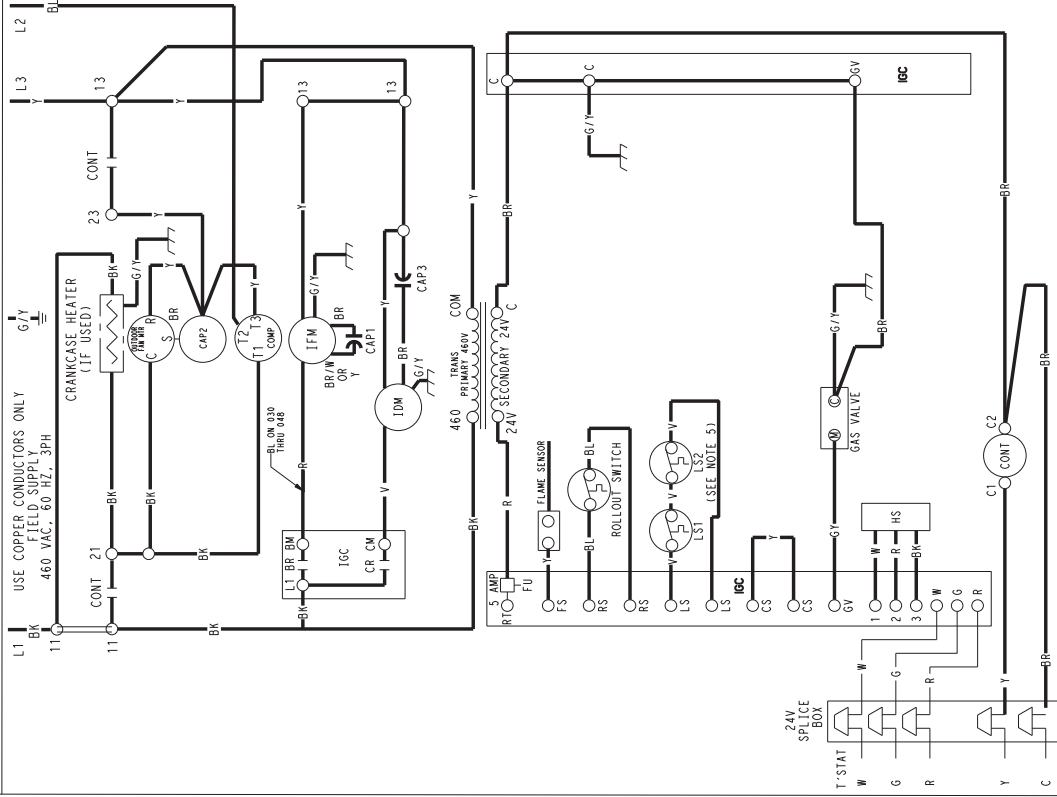

Fig. 15 - 208/230-3-60 Wiring Diagram

LADDER WIRING DIAGRAM

DANGER: ELECTRICAL SHOCK HAZARD DISCONNECT POWER BEFORE SERVICING



48SD500052 4.0

CONNECTION WIRING DIAGRAM

DANGER: ELECTRICAL SHOCK HAZARD DISCONNECT POWER BEFORE SERVICING

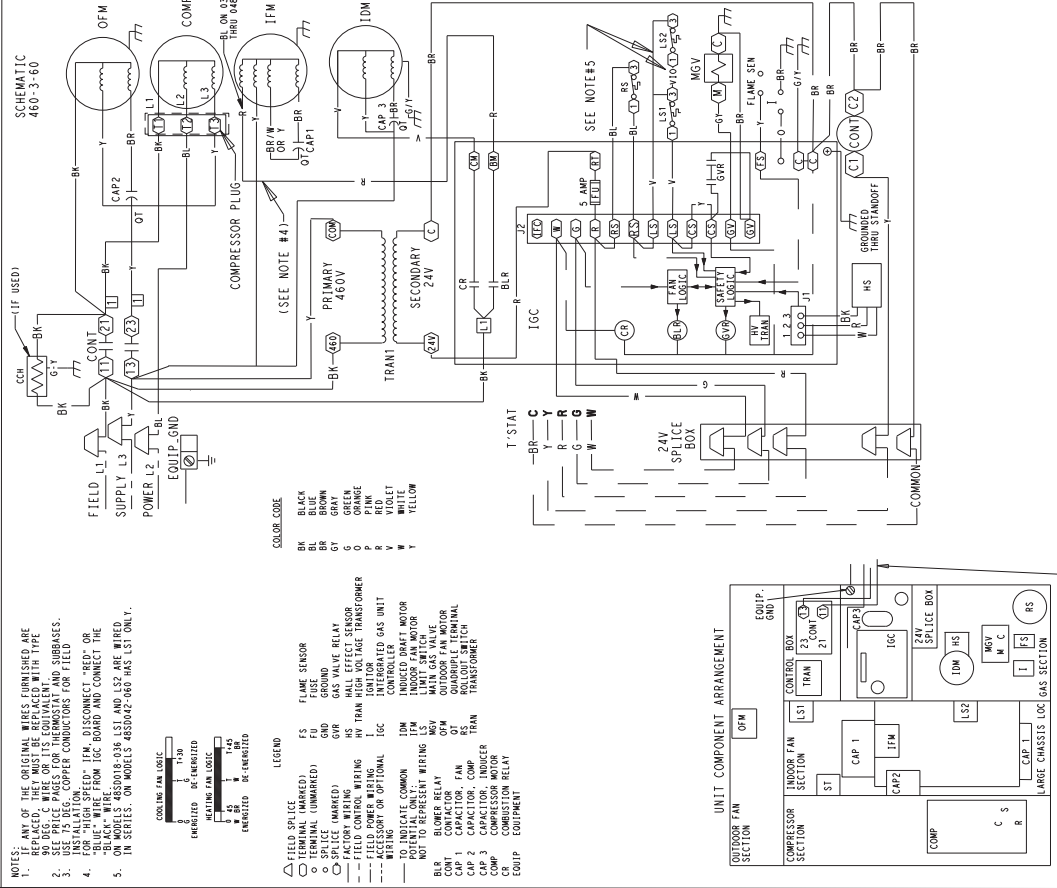

- NOTES:
- IF ANY OF THE ORIGINAL WIRES FURNISHED ARE REFLECTED, THEY MUST BE REPLACED WITH THE SAME TYPE AND SIZE.
 - SEE PRICE PAGES FOR THERMOSTAT AND SUBBASES.
 - USE 15 BGC COPPER CONDUCTORS FOR FIELD.
 - FOR "HIGH SPEED" IFM, DISCONNECT "HEP" OR "BLACK" WIRE.
 - ON MODELS 48SD018-036 L51 AND L52 ARE WIRE IN SERIES. ON MODELS 48SD042-060 HAS L51 ONLY.

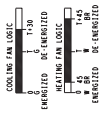

- LEGEND
- △ FIELD SPLICE (C)
 - TERMINAL (UNMARKED)
 - SPUR (S)
 - FACTORY WIRING (F)
 - FIELD CONTROL WIRING (C)
 - FIELD POWER WIRING (P)
 - OPTIONAL WIRING (O)
 - TO INDICATE COMMON (C)
 - NOT TO REPRESENT WIRING (N)
- FLAME SENSOR
FU FUSE
GRD GROUND
GAS VALVE RELAY
HV TRAN HIGH VOLTAGE TRANSFORMER
INDUCTOR
INDUCED DRIFT MOTOR
LIMIT SWITCH
OUTDOOR FAN MOTOR
QUADRUPEL TERMINAL
TRANS TRANSFORMER
EQUIP EQUIPMENT

- COLOR CODE
- BK BLACK
 - BL BLUE
 - BR BROWN
 - GT GREEN
 - OR ORANGE
 - PK PINK
 - RD RED
 - VI VIOLET
 - WH WHITE
 - YL YELLOW

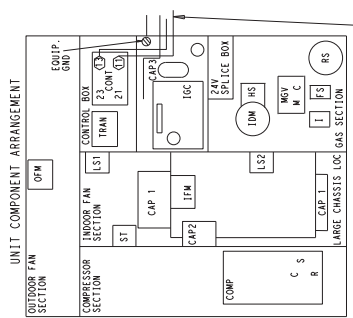

Fig. 16 - 460-3-60 Wiring Diagram

Table 3 – Heating Inputs

HEATING INPUT (BTUH)	NUMBER OF ORIFICES	GAS SUPPLY PRESSURE (IN. WC)				MANIFOLD PRESSURE (IN. WC)	
		Natural†		Propane*†		Natural†	Propane*†
		Min	Max	Min	Max		
40,000	2	4.0	13.0	4.0	13.0	3.5	3.5
60,000	2	4.0	13.0	4.0	13.0	3.5	3.5
90,000	3	4.0	13.0	4.0	13.0	3.5	3.4
115,000	3	4.0	13.0	4.0	13.0	3.5	3.7
130,000	3	4.0	13.0	4.0	13.0	3.5	3.5

*When a unit is converted to propane, different size orifices must be used. See separate, natural-to-propane conversion kit instructions.

†Based on altitudes from sea level to 2000 ft above sea level. For altitudes above 2000 ft, reduce input rating 4 percent for each additional 1000 ft above sea level. In Canada, from 2000 ft above sea level to 4500 ft above sea level, derate the unit 10 percent.

Table 4 – LED Indications

STATUS CODE	LED INDICATION
Normal Operation ²	On
Hardware Failure	Off
Fan On/Off Delay Modified ²	1 Flash
Limit Switch Fault	2 Flashes
Flame Sense Fault	3 Flashes
Four Consecutive Limit Switch Faults	4 Flashes
Ignition Lockout Fault	5 Flashes
Induced-Draft Motor Fault	6 Flashes
Rollout Switch Fault	7 Flashes
Internal Control Fault	8 Flashes
Temporary Lock-Out 1 hr auto reset ¹	9 Flashes

NOTES:

1. This code indicates an internal processor fault that will reset itself in one hr. Fault can be caused by stray RF signals in the structure or nearby. This is a UL requirement.
2. LED indicates acceptable operation. Do not change ignition control board.
3. When W1 is energized the burners will remain on for a minimum of 60 sec.
4. If more than one error mode exists they will be displayed on the LED in sequence.

ROLLOUT SWITCH

The function of the rollout switch is to close the main gas valve in the event of flame rollout. The switch is located above the main burners. When the temperature at the rollout switch reaches the maximum allowable temperature, the control circuit trips, closing the gas valve and stopping gas flow to the burners. The indoor (evaporator) fan motor (IFM) and induced draft motor continue to run until switch is reset. The IGC LED will display FAULT CODE 7.

Step 3 — START-UP COOLING AND MAKE ADJUSTMENTS

Complete the required procedures given in the Pre-Start-Up section before starting the unit. Do not jumper any safety devices when operating the unit. Do not operate the compressor when the outdoor temperature is below 40°F (4.4°C) (unless accessory low-ambient kit is installed). Do not rapid-cycle the compressor. Allow 5 minutes between on cycles to prevent compressor damage.

CHECKING COOLING CONTROL OPERATION

Start and check the unit for proper cooling control operation as follows:

1. Place room thermostat SYSTEM switch in OFF position. Observe that blower motor starts when FAN switch is placed in ON position and shuts down when FAN switch is placed in AUTO position.
2. Place SYSTEM switch in COOL position and FAN switch in AUTO position. Set cooling control below room temperature. Observe that compressor, condenser fan, and evaporator blower motors start. Observe that cooling cycle shuts down when control setting is satisfied. The evaporator fan will continue to run for 30 sec.
3. When using an auto-changeover room thermostat, place both SYSTEM and FAN switches in AUTO positions. Observe that unit operates in Heating mode when

temperature control is set to call for heating (above room temperature) and operates in Cooling mode when temperature control is set to call for cooling (below room temperature).

IMPORTANT: Three-phase, scroll compressors are direction oriented. Unit must be checked to ensure proper compressor 3-phase power lead orientation. If not corrected within 5 minutes, the internal protector will shut off the compressor. The 3-phase power leads to the unit must be reversed to correct rotation. When turning backwards, the difference between compressor suction and discharge pressures may be dramatically lower than normal.

CHECKING AND ADJUSTING REFRIGERANT CHARGE

⚠ CAUTION

UNIT DAMAGE HAZARD

Failure to follow this caution may result in unit damage.

When evaluating the refrigerant charge, an indicated adjustment to the specified factory charge must always be very minimal. If a substantial adjustment is indicated, an abnormal condition exists somewhere in the cooling system, such as insufficient airflow across either coil or both coils.

The refrigerant system is fully charged with R-22 refrigerant and is tested and factory sealed. Allow system to operate a minimum of 15 minutes before checking or adjusting charge.

NOTE: Adjustment of the refrigerant charge is not required unless the unit is suspected of not having the proper R-22 charge.

A refrigerant charging label is attached to the outside of the service access door. The charging label and the tables shown refer to system temperatures and pressures in cooling mode only.

018 Model Only

The charging chart (see Table 6) includes the required liquid line temperature at given discharge line pressures and outdoor ambient temperatures.

An accurate subcooling thermocouple or thermistor-type thermometer and a gauge manifold are required when using the subcooling charging method for evaluating the unit charge. Do not use mercury or small dial-type thermometers because they are not adequate for this type of measurement.

Proceed as follows:

1. Remove caps from low- and high-pressure service fittings.
2. Using hoses with valve core depressors, attach low- and high-pressure gauge hoses to low- and high-pressure service fittings, respectively.
3. Start unit in Cooling Mode and let unit run until system pressures stabilize.
4. Measure and record the following:
 - a. Outdoor ambient-air temperature (°F (°C)db).
 - b. Liquid line temperature (°F (°C)).
 - c. Discharge (high-side) pressure (psig).

PV3P

5. Using “Cooling Charging Charts,” compare outdoor-air temperature (°F (°C) db) with the discharge line pressure (psig) to determine desired system operating liquid line temperature (See Table 6).
6. Compare actual liquid line temperature with desired liquid line temperature. Using a tolerance of $\pm 2^{\circ}\text{F}$ ($\pm 1.1^{\circ}\text{C}$), add refrigerant if actual temperature is more than 2°F (1.1°C) higher than proper liquid line temperature, or remove refrigerant if actual temperature is more than 2°F (1.1°C) lower than required liquid line temperature.

024 through 060 Models

The charging chart (see Table 6A) includes the required suction line temperature at given suction line pressures and outdoor ambient temperatures.

An accurate superheat thermocouple or thermistor-type thermometer and a gauge manifold are required when using the superheat charging method for evaluating the unit charge. Do not use mercury or small dial-type thermometers because they are not adequate for this type of measurement.

Proceed as follows:

1. Remove caps from low- and high-pressure service fittings.
2. Using hoses with valve core depressors, attach low- and high-pressure gauge hoses to low- and high-pressure service fittings, respectively.
3. Start unit in Cooling Mode and let unit run until system pressures stabilize.
4. Measure and record the following:
 - a. Outdoor ambient-air temperature (°F (°C)db).
 - b. Evaporator inlet-air temperature (°F (°C) wb).
 - c. Suction-tube temperature (°F (°C) at low-side service fitting).
 - d. Suction (low-side) pressure (psig).
5. Using “Cooling Charging Charts,” compare outdoor-air temperature(°F (°C) db) with the suction line pressure (psig) to determine desired system operating suction line temperature. (See Fig. Table 6A.)
6. Compare actual suction-tube temperature with desired suction-tube temperature. Using a tolerance of $\pm 3^{\circ}\text{F}$ ($\pm 1.7^{\circ}\text{C}$), add refrigerant if actual temperature is more than 3°F (1.7°C) higher than proper suction-tube temperature, or remove refrigerant if actual temperature is more than 3°F (1.7°C) lower than required liquid line temperature.

NOTE: If the problem causing the inaccurate readings is a refrigerant leak, refer to the Check for Refrigerant Leaks section.

Indoor Airflow and Airflow Adjustments

⚠ CAUTION

UNIT OPERATION HAZARD

Failure to follow this caution may result in unit damage.

For cooling operation, the recommended airflow is 350 to 450 cfm for each 12,000 Btuh of rated cooling capacity. For heating operation, the airflow must produce a temperature rise that falls within the range stamped on the unit rating plate.

Table 8 shows the temperature rise in each heating mode. Refer to these tables to determine the desired heating airflow for the system being installed. (See Table 7 for filter pressure drop and Table 9 for wet coil pressure drop).

NOTE: Be sure that all supply-and return-air grilles are open, free from obstructions, and adjusted properly.

⚠ WARNING

ELECTRICAL SHOCK HAZARD

Failure to follow this warning could result in personal injury or death.

Disconnect electrical power to the unit and install lockout tag before changing blower speed.

Airflow can be changed by changing the lead connections of the blower motor.

All PY3P units are factor wired for low speed except the 030 through the 048 size.

For color coding on the motor leads, see Table 5.

Table 5 – Color Coding for Motor Leads

Black = High Speed
Blue = Medium Speed
Red = Low Speed

To change the speed of the indoor fan motor (IFM), remove the fan motor speed leg lead from the blower relay (BR). This wire is attached to terminal blower motor (BM) of the integrated gas control (IGC) board for single-phase units. To change the speed, remove and replace with lead for desired blower motor speed. Insulate the removed lead to avoid contact with chassis parts.

COOLING SEQUENCE OF OPERATION

With the room thermostat SYSTEM switch in the COOL position and the FAN switch in the AUTO position, the cooling sequence of operation is as follows:

1. When the room temperature rises to a point that is slightly above the cooling control setting of the thermostat, the thermostat completes the circuit between thermostat terminal R to terminals Y and G.
2. The normally open contacts of energized contactor (C) close and complete the circuit through compressor motor (COMP) to condenser (outdoor) fan motor (OFM). Both motors start instantly.
3. The set of normally open contacts of energized relay BM close and complete the circuit through evaporator blower (indoor) fan motor (IFM).

NOTE: Once the compressor has started and then stopped, it should not be started again until 5 minutes have elapsed. The cooling cycle remains on until the room temperature drops to a point that is slightly below the cooling control setting of the room thermostat. At this point, the thermostat breaks the circuit between thermostat terminal R to terminals Y and G. These open circuits deenergize contactor coil C. The condenser and compressor motors stop. After a 30-sec. delay, the blower motor stops. The unit is in a standby condition, waiting for the next call for cooling from the room thermostat.

PY3P

Table 6 – Cooling Charging Chart - 018 only

Model Size	Required Subcooling °F (°C)					Required Liquid Line Temperature for a Specific Subcooling (R-22)									
	Outdoor Ambient Temperature					Required Subcooling (°F)					Required Subcooling (°C)				
	75 (24)	85 (29)	95 (35)	105 (41)	115 (46)	Pressure (psig)	5	10	15	20	Pressure (kPa)	3	6	8	11
018	12 (6.7)	12 (6.7)	12 (6.7)	12 (6.7)	12 (6.7)	134	71	66	61	56	924	22	19	16	13
						141	74	69	64	59	972	23	21	18	15
						148	77	72	67	62	1020	25	22	19	17
						156	80	75	70	65	1076	27	24	21	18
						163	83	78	73	68	1124	28	26	23	20
						171	86	81	76	71	1179	30	27	24	22
						179	89	84	79	74	1234	32	29	26	23
						187	92	87	82	77	1289	33	31	28	25
						196	95	90	85	80	1351	35	32	29	27
						205	98	93	88	83	1413	37	34	31	28
						214	101	96	91	86	1475	38	36	33	30
						223	104	99	94	89	1538	40	37	34	32
						233	107	102	97	92	1606	42	39	36	33
						243	110	105	100	95	1675	43	41	38	35
						253	113	108	103	98	1744	45	42	39	37
						264	116	111	106	101	1820	47	44	41	38
						274	119	114	109	104	1889	48	46	43	40
						285	122	117	112	107	1965	50	47	44	42
						297	125	120	115	110	2048	52	49	46	43
						309	128	123	118	113	2130	53	51	48	45
						321	131	126	121	116	2213	55	52	49	47
						331	134	129	124	119	2282	57	54	51	48
						346	137	132	127	122	2386	58	56	53	50
						359	140	135	130	125	2475	60	57	54	52

PV3P

Table 6A—Cooling Charging Chart - 024 through 060 only

OD Temp. (°F)	Suction Line Temperature (°F)															
	Suction Line Pressure (PSIG)															
	52	54	56	59	61	64	67	70	73	76	79	82	85	89	92	
45	51	55	60	64	69	-	-	-	-	-	-	-	-	-	-	
55	-	-	53	57	62	66	70	-	-	-	-	-	-	-	-	
65	-	-	-	-	53	57	62	66	71	75	-	-	-	-	-	
75	-	-	-	-	-	-	-	56	61	66	71	76	-	-	-	
85	-	-	-	-	-	-	-	-	53	58	63	67	72	-	-	
95	-	-	-	-	-	-	-	-	-	50	54	58	62	66	-	
105	-	-	-	-	-	-	-	-	-	-	50	53	57	60	64	
115	-	-	-	-	-	-	-	-	-	-	49	52	55	58	61	
125	-	-	-	-	-	-	-	-	-	-	-	50	53	56	59	

OD Temp. (°C)	Suction Line Temperature (°C)															
	Suction Line Pressure (kPa)															
	361	370	387	405	423	442	462	482	502	523	544	566	589	612	636	
7	11	13	15	18	21	-	-	-	-	-	-	-	-	-	-	
13	-	-	12	14	16	19	21	-	-	-	-	-	-	-	-	
18	-	-	-	-	12	14	17	19	21	24	-	-	-	-	-	
24	-	-	-	-	-	-	-	13	16	19	22	24	-	-	-	
29	-	-	-	-	-	-	-	-	12	14	17	20	22	-	-	
35	-	-	-	-	-	-	-	-	-	10	12	14	17	19	-	
41	-	-	-	-	-	-	-	-	-	-	10	12	14	16	18	
46	-	-	-	-	-	-	-	-	-	-	9	11	13	14	16	
52	-	-	-	-	-	-	-	-	-	-	-	10	11	13	15	

A05109V2

Table 7 – Filter Pressure Drop Table (in. wc)

FILTER SIZE in. (mm)	CFM																		
	500	600	700	800	900	1000	1100	1200	1300	1400	1500	1600	1700	1800	1900	2000	2100	2200	2300
20X20X1 (508X508X25)	0.05	0.07	0.08	0.1	0.12	0.13	0.14	0.15	—	—	—	—	—	—	—	—	—	—	—
24X30X1 (610X762X25)	—	—	—	0.04	0.05	0.06	0.07	0.07	0.08	0.09	0.1	—	—	—	—	—	—	—	—
24X36X1 (610X914X24)	—	—	—	—	—	—	—	0.06	0.07	0.07	0.08	0.09	0.09	0.10	0.11	0.12	0.13	0.14	0.14

**Table 8 – Dry Coil Air Delivery* - Horizontal and Downflow Discharge -
Unit PY3P018-060 (Deduct 10% for 208 Volts)**

Unit	Heating Rise Range °F	Motor Speed	External Static Pressure (in. wc)										
			0.1	0.2	0.3	0.4	0.5	0.6	0.7	0.8	0.9		
PY3P018040	30 – 60	Low ¹	Watts	260	243	229	217	209	--	--	--	--	--
			CFM	859	775	667	536	382	--	--	--	--	--
			Heating Rise °F	35	39	45	56	NA	NA	NA	NA	NA	
		High	Watts	340	328	317	307	300	294	--	--	--	--
			CFM	1064	948	820	680	528	364	--	--	--	--
			Heating Rise °F	NA	32	37	44	57	NA	NA	NA	NA	
PY3P024040	20 – 50	Low ¹	Watts	311	309	304	301	286	290	286	280	-----	
			CFM	935	885	820	757	686	583	423	263	-----	
			Heating Rise °F	32	34	37	40	44	NA	NA	NA	NA	
		Medium	Watts	411	405	398	390	379	357	357	345	327	
			CFM	1195	1155	1100	1028	957	868	769	647	365	
			Heating Rise °F	25	26	27	29	31	35	39	46	NA	
		High	Watts	528	518	509	492	477	467	447	435	421	
			CFM	1484	1421	1368	1279	1185	1088	970	853	712	
			Heating Rise °F	20	21	22	23	25	28	31	35	42	
PY3P024060	35 – 65	Low ¹	Watts	311	309	304	301	286	290	286	280	-----	
			CFM	935	885	820	757	686	583	423	263	-----	
			Heating Rise °F	48	51	55	59	NA	NA	NA	NA	NA	
		Medium	Watts	411	405	398	390	379	357	357	345	327	
			CFM	1195	1155	1100	1028	957	868	769	647	365	
			Heating Rise °F	38	39	41	44	47	52	59	NA	NA	
		High	Watts	528	518	509	492	477	467	447	435	421	
			CFM	1484	1421	1368	1279	1185	1088	970	853	712	
			Heating Rise °F	NA	NA	NA	35	38	41	46	53	63	
PY3P030040	20 – 50	Low	Watts	311	309	304	301	286	290	286	280	-----	
			CFM	935	885	820	757	686	583	423	263	-----	
			Heating Rise °F	32	34	37	40	44	NA	NA	NA	NA	
		Medium ¹	Watts	411	405	398	390	379	357	357	345	327	
			CFM	1195	1155	1100	1028	957	868	769	647	365	
			Heating Rise °F	25	26	27	29	31	35	39	46	NA	
		High	Watts	528	518	509	492	477	467	447	435	421	
			CFM	1484	1421	1368	1279	1185	1088	970	853	712	
			Heating Rise °F	20	21	22	23	25	28	31	35	42	
PY3P030060	35 – 65	Low	Watts	311	309	304	301	286	290	286	280	-----	
			CFM	935	885	820	757	686	583	423	263	-----	
			Heating Rise °F	48	51	55	59	NA	NA	NA	NA	NA	
		Medium ¹	Watts	411	405	398	390	379	357	357	345	327	
			CFM	1195	1155	1100	1028	957	868	769	647	365	
			Heating Rise °F	38	39	41	44	47	52	59	NA	NA	
		High	Watts	528	518	509	492	477	467	447	435	421	
			CFM	1484	1421	1368	1279	1185	1088	970	853	712	
			Heating Rise °F	NA	NA	NA	35	38	41	46	53	63	
PY3P036060	25 – 55	Low	Watts	439	429	415	401	395	380	356	339	329	
			CFM	1242	1170	1089	994	917	837	702	570	442	
			Heating Rise °F	36	38	41	45	49	54	NA	NA	NA	
		Medium ¹	Watts	503	491	479	461	450	436	418	404	389	
			CFM	1320	1244	1162	1081	1005	897	767	662	541	
			Heating Rise °F	34	36	39	42	45	50	NA	NA	NA	
		High	Watts	641	627	623	609	601	588	571	559	548	
			CFM	1362	1288	1205	1119	1033	933	826	714	580	
			Heating Rise °F	33	35	37	40	44	48	54	NA	NA	
PY3P036090	40 – 70	Low	Watts	439	429	415	401	395	380	356	339	329	
			CFM	1242	1170	1089	994	917	837	702	570	442	
			Heating Rise °F	54	58	62	68	NA	NA	NA	NA	NA	
		Medium ¹	Watts	503	491	479	461	450	436	418	404	389	
			CFM	1320	1244	1162	1081	1005	897	767	662	541	
			Heating Rise °F	51	54	58	62	67	NA	NA	NA	NA	
		High	Watts	641	627	623	609	601	588	571	559	548	
			CFM	1362	1288	1205	1119	1033	933	826	714	580	
			Heating Rise °F	50	52	56	60	65	NA	NA	NA	NA	
PY3P042060	25 – 55	Low	Watts	434	428	422	403	404	390	375	360	344	
			CFM	1282	1241	1206	1160	1109	1040	967	890	813	
			Heating Rise °F	35	36	37	39	41	43	47	51	55	
		Medium ¹	Watts	560	548	535	526	511	496	478	460	439	
			CFM	1526	1482	1437	1398	1344	1281	1205	1125	1029	
			Heating Rise °F	29	30	31	32	33	35	37	40	44	
		High	Watts	765	746	730	709	690	664	642	624	600	
			CFM	1860	1805	1751	1685	1620	1541	1468	1370	1265	
			Heating Rise °F	NA	25	26	27	28	29	31	33	36	
PY3P042090	40 – 70	Low	Watts	434	428	422	403	404	390	375	360	344	
			CFM	1282	1241	1206	1160	1109	1040	967	890	813	
			Heating Rise °F	53	54	56	58	61	65	70	NA	NA	
		Medium ¹	Watts	560	548	535	526	511	496	478	460	439	
			CFM	1526	1482	1437	1398	1344	1281	1205	1125	1029	
			Heating Rise °F	44	46	47	48	50	53	56	60	66	
		High	Watts	765	746	730	709	690	664	642	624	600	
			CFM	1860	1805	1751	1685	1620	1541	1468	1370	1265	
			Heating Rise °F	NA	NA	NA	40	42	44	46	49	53	
PY3P048090	25 – 55	Low	Watts	627	617	607	584	567	548	528	503	480	
			CFM	1550	1530	1493	1461	1414	1361	1320	1250	1177	
			Heating Rise °F	44	44	45	46	48	50	51	54	NA	
		Medium ¹	Watts	771	755	734	711	690	665	639	607	572	
			CFM	1798	1771	1734	1687	1645	1595	1530	1449	1355	
			Heating Rise °F	38	38	39	40	41	42	44	47	50	
		High	Watts	969	941	908	887	858	827	804	767	748	
			CFM	2124	2071	2000	1944	1876	1811	1735	1647	1555	
			Heating Rise °F	32	33	34	35	36	37	39	41	43	
PY3P048115	35 – 65	Low	Watts	627	617	607	584	567	548	528	503	480	
			CFM	1550	1530	1493	1461	1414	1361	1320	1250	1177	
			Heating Rise °F	56	56	58	59	61	63	65	NA	NA	
		Medium ¹	Watts	771	755	734	711	690	665	639	607	572	
			CFM	1798	1771	1734	1687	1645	1595	1530	1449	1355	
			Heating Rise °F	48	49	50	51	52	54	56	60	64	
		High	Watts	969	941	908	887	858	827	804	767	748	
			CFM	2124	2071	2000	1944	1876	1811	1735	1647	1555	
			Heating Rise °F	41	42	43	44	46	48	50	52	55	

PY3P

Table 8 Con't—Dry Coil Air Delivery* - Horizontal and Downflow Discharge - Unit PY3P018-060 (Deduct 10% for 208 Volts)

Unit	Heating Rise Range °F	Motor Speed	External Static Pressure (in. wc)									
			0.1	0.2	0.3	0.4	0.5	0.6	0.7	0.8	0.9	
PY3P048130	40 – 70	Low	Watts	627	617	607	584	567	548	528	503	480
			CFM	1550	1530	1493	1461	1414	1361	1320	1250	1177
			Heating Rise °F	63	64	65	67	69	NA	NA	NA	NA
		Medium ¹	Watts	771	755	734	711	690	665	639	607	572
			CFM	1798	1771	1734	1687	1645	1595	1530	1449	1355
			Heating Rise °F	54	55	56	58	59	61	64	67	NA
		High	Watts	969	941	908	887	858	827	804	767	748
			CFM	2124	2071	2000	1944	1876	1811	1735	1647	1555
			Heating Rise °F	46	47	49	50	52	54	56	59	63
PY3P060090	25 – 55	Low ¹	Watts	786	769	754	736	722	705	684	658	616
			CFM	2027	1960	1901	1821	1759	1693	1616	1513	1354
			Heating Rise °F	33	34	36	37	38	40	42	45	50
		Medium	Watts	873	849	833	815	798	782	763	748	704
			CFM	2095	2026	1962	1887	1817	1748	1679	1583	1439
			Heating Rise °F	32	33	34	36	37	39	40	43	47
		High	Watts	1012	993	981	963	948	927	904	886	846
			CFM	2184	2109	2036	1963	1886	1812	1729	1647	1496
			Heating Rise °F	31	32	33	34	36	37	39	41	45
PY3P060115	35 – 65	Low ¹	Watts	786	769	754	736	722	705	684	658	616
			CFM	2027	1960	1901	1821	1759	1693	1616	1513	1354
			Heating Rise °F	43	44	45	47	49	51	53	57	64
		Medium	Watts	873	849	833	815	798	782	763	748	704
			CFM	2095	2026	1962	1887	1817	1748	1679	1583	1439
			Heating Rise °F	41	43	44	46	47	49	51	54	60
		High	Watts	1012	993	981	963	948	927	904	886	846
			CFM	2184	2109	2036	1963	1886	1812	1729	1647	1496
			Heating Rise °F	39	41	42	44	46	48	50	52	58
PY3P060130	40 – 70	Low ¹	Watts	786	769	754	736	722	705	684	658	616
			CFM	2027	1960	1901	1821	1759	1693	1616	1513	1354
			Heating Rise °F	48	50	51	54	55	58	60	64	NA
		Medium	Watts	873	849	833	815	798	782	763	748	704
			CFM	2095	2026	1962	1887	1817	1748	1679	1583	1439
			Heating Rise °F	47	48	50	52	54	56	58	62	68
		High	Watts	1012	993	981	963	948	927	904	886	846
			CFM	2184	2109	2036	1963	1886	1812	1729	1647	1496
			Heating Rise °F	45	46	48	50	52	54	56	59	65

*Air delivery values are without air filter and are for dry coil (see Wet Coil Pressure Drop table).

¹Factory – shipped heating/cooling speed

“NA” = Not allowed for heating speed

Note: Deduct field – supplied air filter pressure drop and wet coil pressure drop to obtain external static pressure available for ducting.

Table 9 – PY3P Wet Coil Pressure Drop (in. wc)

UNIT SIZE	STANDARD CFM (S.C.F.M.)														
	500	600	700	800	900	1000	1200	1300	1400	1500	1600	1700	1800	1900	2000
018	0.011	0.013	0.018	0.022	-	-	-	-	-	-	-	-	-	-	-
024	-	0.030	0.037	0.044	0.053	0.063	-	-	-	-	-	-	-	-	-
030	-	-	0.037	0.044	0.053	0.063	0.072	0.081	0.105	-	-	-	-	-	-
036	-	-	-	-	0.05	0.061	0.072	0.080	0.090	0.110	-	-	-	-	-
042	-	-	-	-	-	0.044	0.051	0.059	0.065	0.072	0.080	0.088	0.095	0.105	-
048	-	-	-	-	-	-	-	0.044	0.050	0.053	0.059	0.066	0.072	0.077	0.086
060	-	-	-	-	-	-	-	-	-	-	0.079	0.087	0.095	0.102	0.113

MAINTENANCE

To ensure continuing high performance and to minimize the possibility of premature equipment failure, periodic maintenance must be performed on this equipment. This unit should be inspected at least once each year by a qualified service person. To troubleshoot unit, refer to Table 10, Troubleshooting Chart.

NOTE TO EQUIPMENT OWNER: Consult your local dealer about the availability of a maintenance contract.

⚠ WARNING

PERSONAL INJURY AND UNIT DAMAGE HAZARD

Failure to follow this warning could result in personal injury or death and unit component damage.

The ability to properly perform maintenance on this equipment requires certain expertise, mechanical skills, tools and equipment. If you do not possess these, do not attempt to perform any maintenance on this equipment, other than those procedures recommended in the Owner's Manual.

⚠ WARNING

ELECTRICAL SHOCK HAZARD

Failure to follow these warnings could result in personal injury or death:

1. Turn off electrical power to the unit before performing any maintenance or service on this unit.
2. Use extreme caution when removing panels and parts.
3. Never place anything combustible either on or in contact with the unit.

⚠ CAUTION

UNIT OPERATION HAZARD

Failure to follow this caution may result in improper operation.

Errors made when reconnecting wires may cause improper and dangerous operation. Label all wires prior to disconnecting when servicing.

The minimum maintenance requirements for this equipment are as follows:

1. Inspect air filter(s) each month. Clean or replace when necessary.
2. Inspect indoor coil, drain pan, and condensate drain each cooling season for cleanliness. Clean when necessary.
3. Inspect blower motor and wheel for cleanliness at the beginning of each heating and cooling season. Clean when necessary. For first heating and cooling season, inspect blower wheel bi-monthly to determine proper cleaning frequency.
4. Check electrical connections for tightness and controls for proper operation each heating and cooling season. Service when necessary.
5. Ensure electric wires are not in contact with refrigerant tubing or sharp metal edges.
6. Check and inspect heating section before each heating season. Clean and adjust when necessary.
7. Check flue hood and remove any obstructions, if necessary.

AIR FILTER

IMPORTANT: Never operate the unit without a suitable air filter in the return-air duct system. Always replace the filter with the same dimensional size and type as originally installed. See Table 1 for recommended filter sizes.

Inspect air filter(s) at least once each month and replace (throwaway-type) or clean (cleanable-type) at least twice during each cooling season and twice during the heating season, or whenever the filter becomes clogged with dust and lint.

INDOOR BLOWER AND MOTOR

NOTE: All motors are pre-lubricated. Do not attempt to lubricate these motors.

For longer life, operating economy, and continuing efficiency, clean accumulated dirt and grease from the blower wheel and motor annually.

⚠ WARNING

ELECTRICAL SHOCK HAZARD

Failure to follow this warning could result in personal injury or death.

Disconnect and tag electrical power to the unit before cleaning and lubricating the blower motor and wheel.

To clean the blower motor and wheel:

1. Remove and disassemble blower assembly as follows:
 - a. Remove unit access panel.
 - b. Disconnect motor lead from blower relay (BM). Disconnect yellow lead from terminal L2 of the contactor.
 - c. On all units remove blower assembly from unit. Remove screws securing blower to blower partition and slide assembly out. Be careful not to tear insulation in blower compartment.
 - d. Ensure proper reassembly by marking blower wheel and motor in relation to blower housing before disassembly.
 - e. Loosen setscrew(s) that secures wheel to motor shaft, remove screws that secure motor mount brackets to housing, and slide motor and motor mount out of housing.
2. Remove and clean blower wheel as follows:
 - a. Ensure proper reassembly by marking wheel orientation.

- b. Lift wheel from housing. When handling and/or cleaning blower wheel, be sure not to disturb balance weights (clips) on blower wheel vanes.
 - c. Remove caked-on dirt from wheel and housing with a brush. Remove lint and/or dirt accumulations from wheel and housing with vacuum cleaner, using soft brush attachment. Remove grease and oil with mild solvent.
 - d. Reassemble wheel into housing.
 - e. Reassemble motor into housing. Be sure setscrews are tightened on motor shaft flats and not on round part of shaft.
 - f. Reinstall unit access panel.
3. Restore electrical power to unit. Start unit and check for proper blower rotation and motor speeds during heating and cooling cycles.

FLUE GAS PASSAGEWAYS

To inspect the flue collector box and upper areas of the heat exchanger:

1. Remove the induced-draft blower assembly according to directions below.
2. Remove the flue collector box cover (See Fig. 17) from the heat exchanger assembly. Inspect the heat exchangers.
3. Clean all surfaces, as required, using a wire brush.

INDUCED-DRAFT (COMBUSTION AIR) BLOWER ASSEMBLY

The induced-draft blower assembly consists of the inducer motor, the blower housing, and the induced-draft blower wheel.

Clean periodically to assure proper airflow and heating efficiency. Inspect blower wheel every fall and periodically during the heating season. For the first heating season, inspect blower wheel bimonthly to determine proper cleaning frequency.

To inspect blower wheel, remove draft hood assembly. Shine a flashlight into opening to inspect wheel. If cleaning is required, remove induced-draft blower assembly as follows:

1. Remove unit access panel (See Fig. 18).
2. Remove the 7 screws that attach induced-draft motor assembly to the flue collector box cover.
3. Slide the assembly out of the unit. (See Fig. 19). Clean the blower wheel. If additional cleaning is required, continue with Steps 4 and 5.
4. To remove blower wheel, remove 2 setscrews.
5. To remove inducer motor, remove screws that hold the inducer motor to the blower housing.
6. To reinstall, reverse the procedure outlined above.

LIMIT SWITCH

Remove unit access panel. Limit switch is located on the blower partition.

NOTE: Some models have two limit switches.

BURNER IGNITION

Unit is equipped with a direct spark ignition 100 percent lockout system. Ignition module is located in the control box (See Fig. 17). Module contains a self-diagnostic LED. During servicing, refer to label diagram for LED interpretation.

If lockout occurs, unit may be reset by either momentarily interrupting power supply to unit or by turning selector switch to OFF position at the thermostat.

MAIN BURNERS

At the beginning of each heating season, inspect for deterioration or blockage due to corrosion or other causes. Observe the main burner flames and adjust, if necessary.

Removal of Burner Assembly

To remove the burner assembly for servicing:

1. Shut off main gas valve.
2. Shut off power to unit and install lockout tag.
3. Remove unit access panel (See Fig. 18).
4. Disconnect gas piping at unit gas valve.
5. Remove wires connected to gas valve. Mark each wire.
6. Remove ignitor and sensor wires at the ignitor module.
7. Remove the mounting screw that attaches the burner rack to the unit base (See Fig. 17).
8. Slide the burner rack out of the unit (See Fig. 17 and 20).
9. To reinstall, reverse the procedure outlined above.

Outdoor Coil, Indoor Coil, and Condensate Drain Pan

Inspect the condenser coil, evaporator coil, and condensate drain pan at least once each year.

The coils are easily cleaned when dry; therefore, inspect and clean the coils either before or after each cooling season. Remove all obstructions, including weeds and shrubs, that interfere with the airflow through the condenser coil.

Straighten bent fins with a fin comb. If coated with dirt or lint, clean the coils with a vacuum cleaner, using the soft brush attachment. Be careful not to bend the fins. If coated with oil or grease, clean the coils with a mild detergent and water solution. Rinse coils with clear water, using a garden hose. Be careful not to splash water on motors, insulation, wiring, or air filter(s). For best results, spray condenser coil fins from inside to outside the unit. On units with an outer and inner condenser coil, be sure to clean between the coils. Be sure to flush all dirt and debris from the unit base.

Inspect the drain pan and condensate drain line when inspecting the coils. Clean the drain pan and condensate drain by removing all foreign matter from the pan. Flush the pan and drain trough with clear water. Do not splash water on the insulation, motor, wiring, or air filter(s). If the drain trough is restricted, clear it with a “plumbers snake” or similar probe device.

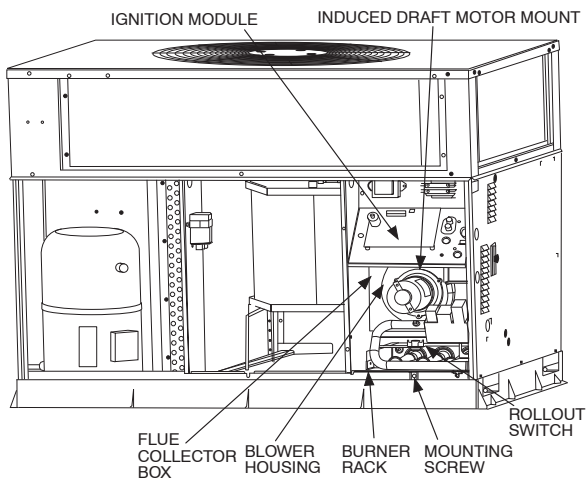

Fig. 17 - Blower Housing and Flue Collector Box

A05119

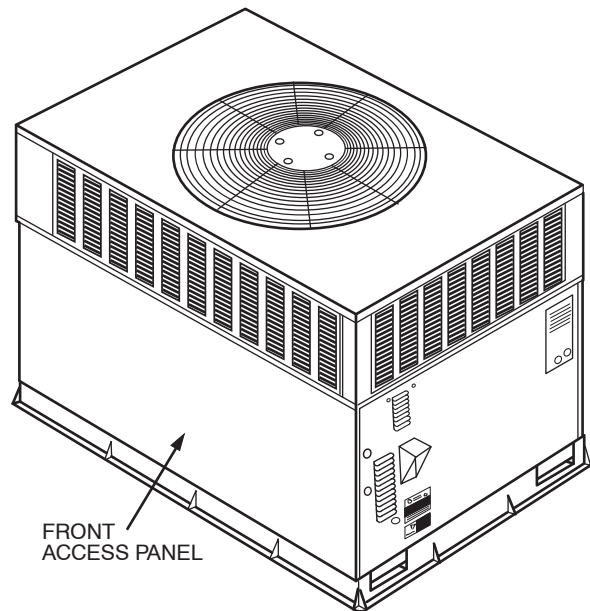

Fig. 18 - Unit Access Panel

C99091

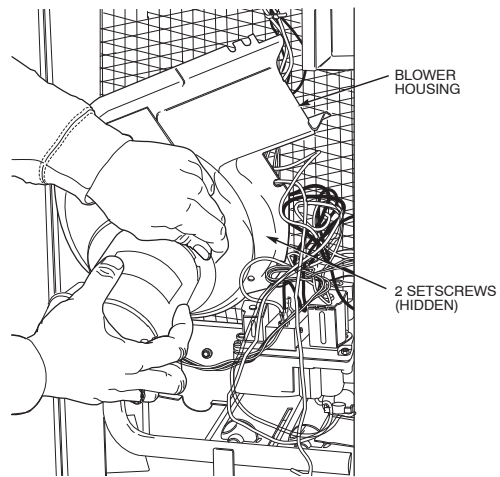

Fig. 19 - Removal of Induced-Draft Blower Assembly

C99085

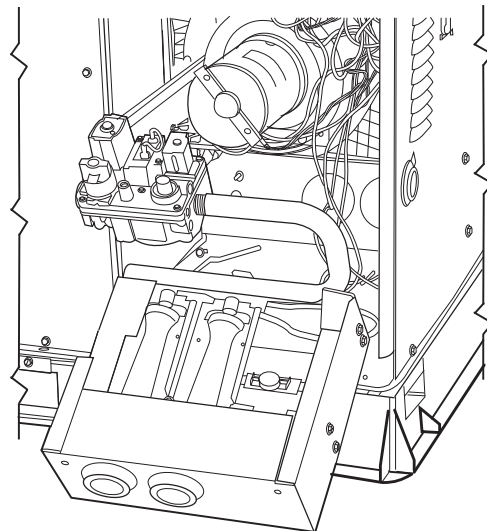

Fig. 20 - Burner Rack Removed

C99086

Outdoor Fan



CAUTION

UNIT OPERATION HAZARD

Failure to follow this caution may result in damage to unit components.

Keep the condenser fan free from all obstructions to ensure proper cooling operation. Never place articles on top of the unit.

1. Remove 6 screws holding outdoor grille and motor to top cover.
2. Turn motor/grille assembly upside down on top cover to expose fan blade.
3. Inspect the fan blades for cracks or bends.
4. If fan needs to be removed, loosen setscrew and slide fan off motor shaft.
5. When replacing fan blade, position blade so that the hub is 1/8 in. away from the motor end (1/8 in. of motor shaft will be visible).
6. Ensure that setscrew engages the flat area on the motor shaft when tightening.
7. Replace grille.

Electrical Controls and Wiring

Inspect and check the electrical controls and wiring annually. Be sure to turn off the electrical power to the unit.

Remove access panel to locate all the electrical controls and wiring. Check all electrical connections for tightness. Tighten all screw connections. If any smoky or burned connections are noticed, disassemble the connection, clean all the parts, re-strip the wire end and reassemble the connection properly and securely.

After inspecting the electrical controls and wiring, replace all the panels. Start the unit, and observe at least one complete cooling cycle to ensure proper operation. If discrepancies are observed in operating cycle, or if a suspected malfunction has occurred, check each electrical component with the proper electrical instrumentation. Refer to the unit wiring label when making these checks.

Refrigerant Circuit

Inspect all refrigerant tubing connections and the unit base for oil accumulation annually. Detecting oil generally indicates a refrigerant leak.



WARNING

EXPLOSION, PERSONAL INJURY HAZARD

Failure to follow this warning could result in property damage, personal injury or death.

System under pressure. Relieve pressure and recover all refrigerant before system repair or final unit disposal. Use all service ports and open all flow-control devices, including solenoid valves.

If oil is detected or if low performance is suspected, leak test all refrigerant tubing using an electronic leak detector, or liquid-soap solution. If a refrigerant leak is detected, refer to **Check for Refrigerant Leaks** section.

If no refrigerant leaks are found and low performance is suspected, refer to **Checking and Adjusting Refrigerant Charge** section.

Indoor Airflow

The heating and/or cooling airflow does not require checking unless improper performance is suspected. If a problem exists, be sure that all supply- and return-air grilles are open and free from obstructions, and that the air filter is clean.

Metering Devices

018 Model Only-TXV

This metering device is a hard shutoff, balance port TXV. The TXV maintains a constant superheat at the evaporator exit resulting in higher overall system efficiency.

024 through 060 Models-AccuRater Piston

Refrigerant metering device is a fixed orifice and is located in the distributor assembly to the indoor coil.

TROUBLESHOOTING

Refer to the Troubleshooting Chart (Table 10-12) for troubleshooting information.

START-UP CHECKLIST

Use the Start-Up Checklist at the back of this manual.

Table 10 – Troubleshooting Chart

SYMPTOM	CAUSE	REMEDY
Compressor and condenser fan will not start.	Power failure	Call power company
	Fuse blown or circuit breaker tripped	Replace fuse or reset circuit breaker
	Defective contactor, transformer, or high-pressure, loss-of-charge or low-pressure switch	Replace component
	Insufficient line voltage	Determine cause and correct
	Incorrect or faulty wiring	Check wiring diagram and rewire correctly
	Thermostat setting too high	Lower thermostat temperature setting below room temperature
Compressor will not start but condenser fan runs	Faulty wiring or loose connections in compressor circuit	Check wiring and repair or replace
	Compressor motor burned out, seized, or internal overload open	Determine cause Replace compressor
	Defective run/start capacitor, overload, start relay	Determine cause and replace
	One leg of 3-phase power dead	Replace fuse or reset circuit breaker Determine cause
	Low input voltage (20% low)	Determine cause and correct
Three-phase scroll compressor makes excessive noise, and there may be a low pressure differential.	Scroll compressor is rotating in the wrong direction	Correct the direction of rotation by reversing the 3-phase power leads to the unit. Shut down unit to allow pressures to equalize.
Compressor cycles (other than normally satisfying thermostat)	Refrigerant overcharge or undercharge	Recover refrigerant, evacuate system, and recharge to capacities shown on rating plate
	Defective compressor	Replace and determine cause
	Insufficient line voltage	Determine cause and correct
	Blocked outdoor coil	Determine cause and correct
	Defective run/start capacitor	Determine cause and replace
	Faulty outdoor fan motor or capacitor	Replace
	Restriction in refrigerant system	Locate restriction and remove
Compressor operates continuously	Dirty air filter	Replace filter
	Unit undersized for load	Decrease load or increase unit size
	thermostat temperature set too low	Reset thermostat
	Low refrigerant charge	Locate leak, repair, and recharge
	Air in system	Recover refrigerant, evacuate system, and recharge
	Outdoor coil dirty or restricted	Clean coil or remove restriction
Excessive head pressure	Dirty air filter	Replace filter
	Dirty condenser coil	Clean coil
	Refrigerant overcharged	Recover excess refrigerant
	Air in system	Recover refrigerant, evacuate system, and recharge
	Condenser air restricted or air short-cycling	Determine cause and correct
Head pressure too low	Low refrigerant charge	Check for leaks, repair, and recharge.
	Restriction in liquid tube	Remove restriction
Excessive suction pressure	High heat load	Check for source and eliminate
	Compressor valves leaking	Replace compressor
	Refrigerant overcharged	Recover excess refrigerant
Suction pressure too low	Dirty air filter	Replace filter
	Low refrigerant charge	Check for leaks, repair and recharge
	Metering device or low side restricted	Remove source of restriction
	Insufficient evaporator airflow	Increase air quantity Check filter—replace if necessary
	Temperature too low in conditioned area	Reset thermostat
	Outdoor ambient below 55°F	Install low-ambient kit
	Filter drier restricted	Replace filter

PY3P

Table 11 – Troubleshooting Guide–Heating

SYMPTOM	CAUSE	REMEDY
Burners will not ignite	Water in gas line	Drain. Install drip leg.
	No power to furnace	Check power supply fuses, wiring or circuit breaker.
	No 20-v power supply to control circuit	Check transformer. NOTE: Some transformers have internal over-current protection that requires a cool-down period to reset.
	Mis-wired or loose connections	Check all wiring and wire nut connections
	Misaligned spark electrodes	Check flame ignition and sense electrode positioning. Adjust as necessary.
	No gas at main burners	1. Check gas line for air. Purge as necessary. NOTE: After purging gas line of air, wait at least 5 minutes for any gas to dissipate before attempting to light unit. 2. Check gas valve.
Inadequate heating	Dirty air filter	Clean or replace filter as necessary
	Gas input to furnace too low	Check gas pressure at manifold match with that on unit nameplate
	Unit undersized for application	Replace with proper unit or add additional unit
	Restricted airflow	Clean or replace filter. Remove any restriction.
	Limit switch cycles main burners	Check rotation of blower, temperature rise of unit. Adjust as necessary.
Poor flame characteristics	Incomplete combustion results in: Aldehyde odors, carbon monoxide, sooting flame, floating flame	1. Tighten all screws around burner compartment 2. Cracked heat exchanger. Replace. 3. Unit over-fired. Reduce input (change orifices or adjust gas line or manifold pressure). 4. Check burner alignment. 5. Inspect heat exchanger for blockage. Clean as necessary.

Table 12 – Troubleshooting Guide–LED Status Codes

SYMPTOM	CAUSE	REMEDY
Hardware failure (LED OFF)	Loss of power to control module (IGC)*.	Check 5-amp fuse on IGC*, power to unit, 24-v circuit breaker, and transformer. Units without a 24-v circuit breaker have an internal overload in the 24-v transformer. If the overload trips, allow 10 minutes for automatic reset.
Limit switch faults (LED 2 flashes)	High temperature limit switch is open.	Check the operation of the indoor (evaporator) fan motor. Ensure that the supply-air temperature rise is in accordance with the range on the unit nameplate. Clean or replace filters.
Flame sense fault (LED 3 flashes)	The IGC* sensed flame that should not be present.	Reset unit. If problem persists, replace control board.
4 consecutive limit switch faults (LED 4 flashes)	Inadequate airflow to unit.	Check the operation of the indoor (evaporator) fan motor and that supply-air temperature rise agrees with range on unit nameplate information.
Ignition lockout (LED 5 flashes)	Unit unsuccessfully attempted ignition for 15 minutes.	Check ignitor and flame sensor electrode spacing, gaps, etc. Ensure that flame sense and ignition wires are properly terminated. Verify that unit is obtaining proper amount of gas.
Induced-draft motor fault (LED 6 flashes)	IGC does not sense that induced-draft motor is operating.*	Check for proper voltage. If motor is operating, check the speed sensor plug/IGC Terminal J2 connection. Proper connection: PIN 1 - White PIN 2 - Red PIN 3 - Black
Rollout switch fault (LED 7 flashes)	Rollout switch has opened.	Rollout switch will automatically reset, but IGC* will continue to lockout unit. Check gas valve operation. Ensure that induced-draft blower wheel is properly secured to motor shaft. Inspect heat exchanger. Reset unit at unit disconnect.
Internal control fault (LED 8 flashes)	Microprocessor has sensed an error in the software or hardware.	If error code is not cleared by resetting unit power, replace the IGC*.
Temporary software lockout (LED 9 flashes)	Electrical interference impeding IGC software	Reset 24-v. to control board or turn thermostat off, then on again. Fault will automatically reset itself in one (1) hour.

***WARNING** ⚠: If the IGC must be replaced, be sure to ground yourself to dissipate any electrical charge that may be present before handling new control board. The IGC is sensitive to static electricity and may be damaged if the necessary precautions are not taken.

IMPORTANT: Refer to Table 11 – Troubleshooting Guide – Heating for additional troubleshooting analysis.

LEGEND

IGC—Integrated Gas Unit Controller

LED—Light – Emitting Diode

PY3P

START-UP CHECKLIST
(Remove and Store in Job File)

I. Preliminary Information

MODEL NO.: _____
SERIAL NO.: _____
DATE: _____
TECHNICIAN: _____

II. PRE-START-UP (Insert checkmark in box as each item is completed)

- VERIFY THAT ALL PACKING MATERIALS HAVE BEEN REMOVED FROM UNIT
- REMOVE ALL SHIPPING HOLD DOWN BOLTS AND BRACKETS PER INSTALLATION INSTRUCTIONS
- CHECK ALL ELECTRICAL CONNECTIONS AND TERMINALS FOR TIGHTNESS
- CHECK GAS PIPING FOR LEAKS (WHERE APPLICABLE)
- CHECK THAT INDOOR (EVAPORATOR) AIR FILTER IS CLEAN AND IN PLACE
- VERIFY THAT UNIT INSTALLATION IS LEVEL
- CHECK FAN WHEEL, AND PROPELLER FOR LOCATION IN HOUSING/ORIFICE AND SETSCREW TIGHTNESS

PY3P

III. START-UP

ELECTRICAL

SUPPLY VOLTAGE _____
COMPRESSOR AMPS _____
INDOOR (EVAPORATOR) FAN AMPS _____

TEMPERATURES

OUTDOOR (CONDENSER) AIR TEMPERATURE _____ DB
RETURN-AIR TEMPERATURE _____ DB _____ WB
COOLING SUPPLY AIR _____ DB _____ WB
GAS HEAT SUPPLY AIR _____

PRESSURES

GAS INLET PRESSURE _____ IN.WG
GAS MANIFOLD PRESSURE _____ IN.WG
REFRIGERANT SUCTION _____ PSIG SUCTION LINE TEMP* _____
REFRIGERANT DISCHARGE _____ PSIG DISCHARGE TEMP† _____

- VERIFY REFRIGERANT CHARGE USING CHARGING CHARTS

GAS HEAT TEMPERATURE RISE
TEMPERATURE RISE (See Literature) RANGE _____
MEASURED TEMPERATURE RISE _____

*Measured at suction inlet to compressor
†Measured at liquid line leaving condenser.