



Safety and Installation Instructions

Model 1700

READ COMPLETE INSTALLATION INSTRUCTIONS BEFORE STARTING. SAVE THIS MANUAL.

TABLE OF CONTENTS

Safety Instructions	2	Location	7
Specification Overview	2	Ducting	8
Installation Overview	3	Air Filter	9
Whole-House Dehumidifier Operation and Installations	3	Wiring	10
Localized Dehumidifier Operation and Installation	4	Control and Setup	12
Whole-House Convertible to Localized Dehumidifier Operation and Installation	5	Troubleshooting Guide	14

SAFETY INSTRUCTIONS

WARNING

ATTENTION INSTALLER: This product must be installed by a qualified heating and air conditioning contractor. Failure to do so could result in serious injury from electrical shock or damage to product.

WARNING

- 1. 120 volts may cause serious injury from electric shock.** Disconnect electrical power before starting installation. Leave power disconnected until installation is completed.
- 2. Sharp edges may cause serious injury from cuts.** Use care when cutting plenum openings and handling ductwork.
- 3. Unit weight and dropping may cause personal injury or equipment damage.** Handle with care.

CAUTION

- 1. Unit must be transported and installed in an upright position.** If the unit is tilted on its side, a 24 hour settling period is required before running the unit.
- 2. Installation must conform to all applicable codes.**
- 3. If unit is ducted to an HVAC system, ΔP must be ≤ 0.8 " w.c. external static pressure across the dehumidifier, which corresponds to a dehumidifier airflow rate of 210 minimum.**

SPECIFICATION OVERVIEW

The purpose of the Aprilaire® Dehumidifier is to keep the humidity in the house at acceptable limits to reduce the unwanted effects of high humidity. The dehumidifier will gather data from the HVAC system and measure the dew point of the house air to decide when to run. The dryness set point can be adjusted with the control knob on the side of the unit. The integrated air cycling feature will be able to turn on the HVAC blower to cycle air through the house to balance the indoor conditions. This feature is set up during installation based on house size and homeowner preference. An optional ventilation damper can also be installed to bring in outside air during air cycling.

Model: Aprilaire Model 1700

Dimensions: 20"W x 24"L x 21.75"H

Weight: 100 lbs

Capacity: 90 pints per day @ 60% RH, 80°F (ANSI/AHAM DH-1-2003 conditions)

Power: 115 VAC, 9 Amps. Unit equipped with an 8 ft. grounded power cord.

Airflow: 275 CFM @ 0.6 in. w.c. external static pressure.

Filter: Aluminum frame filter, foam core.
Recommended replacement frequency = 1 year.

Cabinet Insulation: Entire interior surface is sealed with 1" foil faced EPS insulation.

Inlet Air Operating Conditions: 40°F to 105°F

INSTALLATION OVERVIEW

	<u>SEE PAGE</u>	<u>SEE PAGE</u>
STEP 1: Select the type of installation.		
a. Whole-house	3	
b. Localized	4	
c. Whole-house Convertible to Localized	5	
STEP 2: Determine if outside ventilation will be included with dehumidification system (Ventilation time calculation included)	11	
STEP 3: Select location and mounting method for dehumidifier		7
STEP 4: Install ductwork including dampers if used		8
STEP 5: Install wiring		10
STEP 6: Set up control		12
STEP 7: Checkout system		13

WHOLE-HOUSE DEHUMIDIFIER OPERATION AND INSTALLATIONS

In this configuration, the dehumidifier will pull air from the principle living space or the return duct. The air passes through the dehumidifier, where moisture is removed, and then is returned to the HVAC system downstream of the cooling coil in the main supply duct. The dehumidifier will turn on with the first HVAC blower call in each time interval (see CONTROL AND SETUP section on page 12 to set time interval) in order to get an accurate air sample. If no HVAC blower call occurs during the time interval, the dehumidifier will activate its own internal blower and take an air sample. If the incoming air is above the set point, the dehumidifier compressor will turn on. Even if the HVAC blower shuts off, the dehumidifier will continue to run until the set point is satisfied. If an HVAC call starts when the dehumidifier is running the dehumidifier will continue to run.

WHOLE-HOUSE, PRINCIPLE LIVING SPACE TO SUPPLY

In this installation, the inlet to the dehumidifier will come from a new return duct installed in a principle living space. Air is drawn from this area, through the dehumidifier and into the supply duct of the HVAC system, as shown in **Figure 1**.

Note: Due to backflow of air through the dehumidifier while it is not running, it is recommended to install an optional powered damper (6508). A wiring connection is provided. A 24-volt transformer (not provided) is required to power the damper.

A barometric or other backdraft damper **should not** be used due to the large pressure drop.

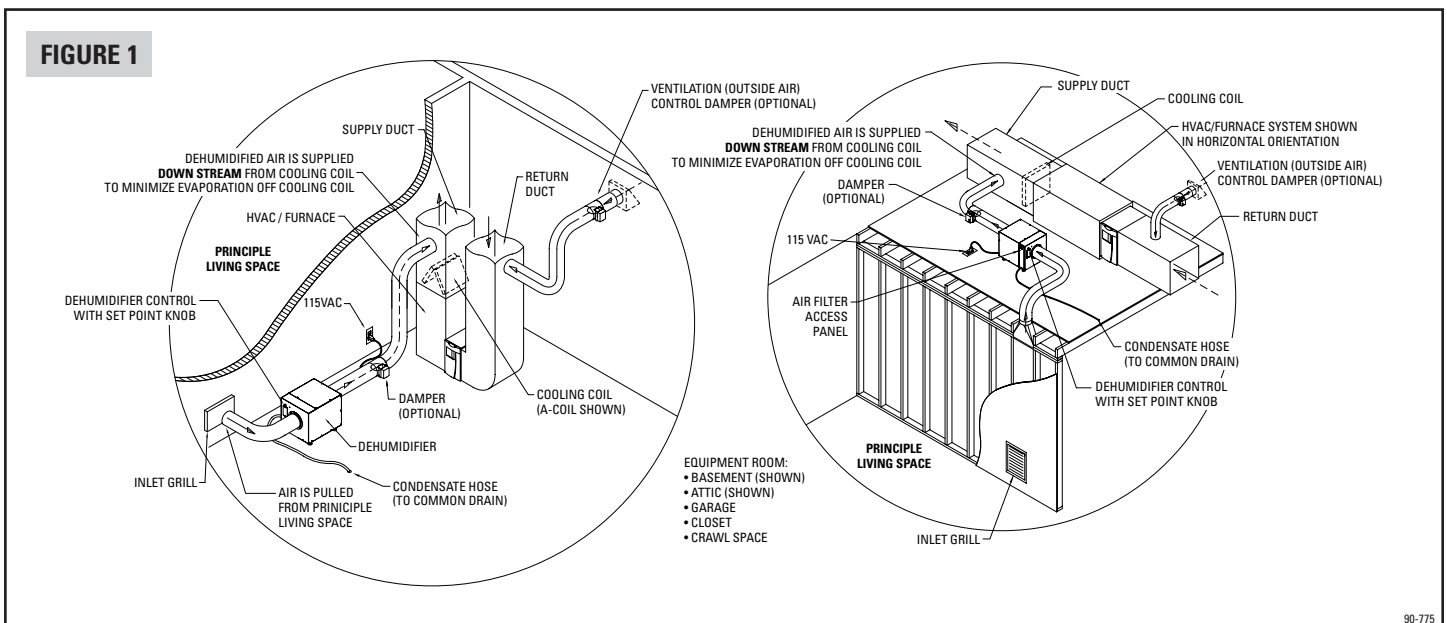

WHOLE-HOUSE, RETURN TO SUPPLY

This installation (**Figure 2**) is similar to the “Principle Living Space to Supply” installation, except that the inlet to the dehumidifier will come from a bypass duct from the HVAC system’s return duct rather than the principle living space.

Note: An optional powered damper (6508) is recommended to be installed on the dehumidifier outlet to prevent airflow from recirculating through the dehumidifier when the HVAC system is on and dehumidifier is off. A wiring connection is provided. A 24-volt transformer (not provided) is required to power the damper.

A barometric or other backdraft damper **should not** be used due to the large pressure drop.

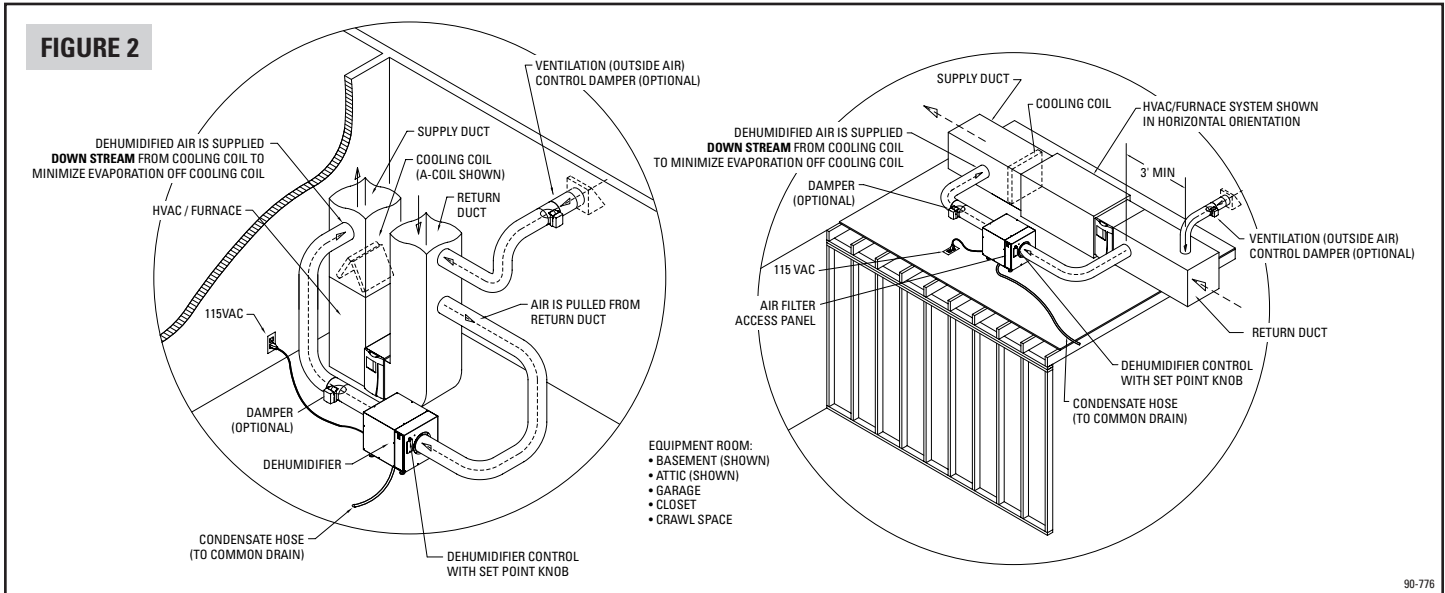

LOCALIZED DEHUMIDIFIER OPERATION AND INSTALLATION

In this configuration (**Figure 3**), the dehumidifier will pull air from the principle living space and return it to the same space. If wired to the HVAC system (necessary for whole house air cycling, see CONTROL AND SETUP section on page 12 for detailed information), the dehumidifier will still turn on with the first HVAC blower call in each time interval. If no HVAC blower call occurs during a time interval or the unit is not wired to the HVAC, the dehumidifier will activate its own internal blower and take an air sample. If the incoming air is above the set point, the dehumidifier (compressor) will turn on and run until the set point is satisfied. We recommend air cycling be enabled to move this drier air throughout the house.

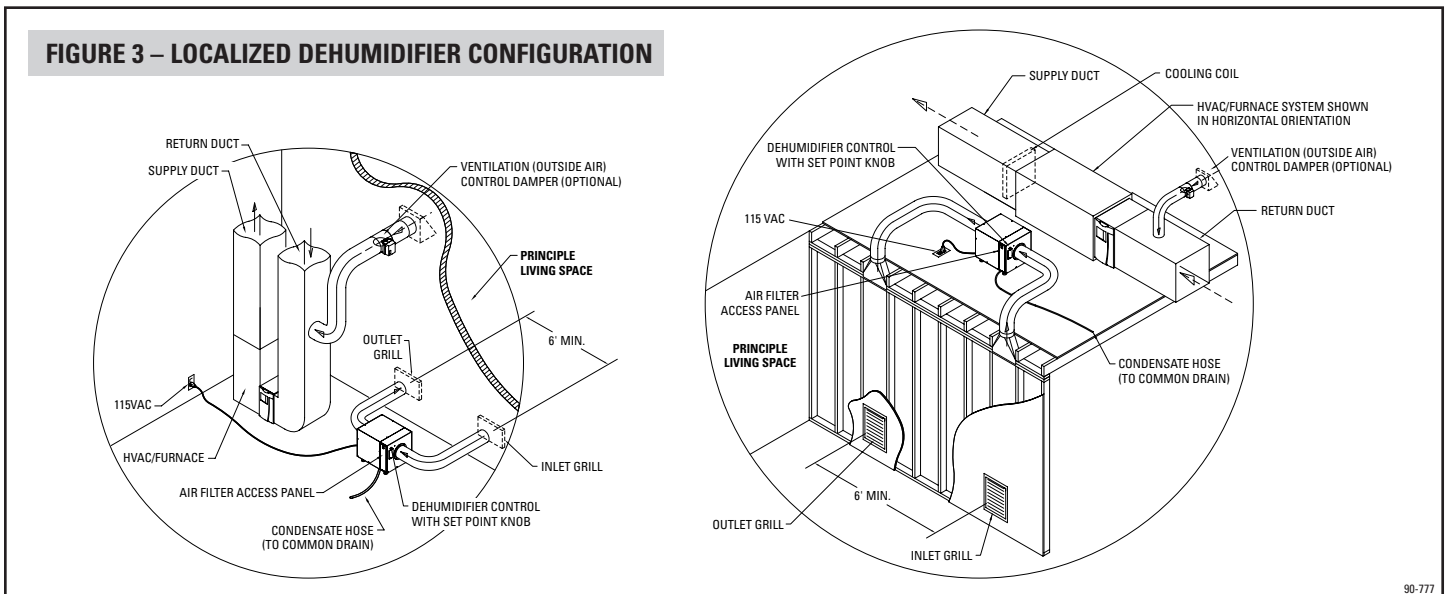

WHOLE-HOUSE CONVERTIBLE TO LOCALIZED DEHUMIDIFIER OPERATION AND INSTALLATION

In this configuration, the dehumidifier will automatically switch between whole-house dehumidification when the HVAC equipment is on, and localized dehumidification when the HVAC equipment is off.

WHOLE-HOUSE, WITH LOCALIZED OPTION FOR CONDITIONED SPACE

This installation is used to dehumidify a whole house and also a separate conditioned space like a finished basement. Two dampers are installed, one normally-closed damper (6508) is installed in the branch leading from the dehumidifier to the supply duct, and one normally-open damper (6608) is installed in the branch leading from the dehumidifier back to the conditioned space. For convenience, a basement kit (4522), which includes a normally-closed damper (6508), a normally-open damper (6608), and a 40VA, 24 VAC plug in transformer (8027) can be ordered.

When the HVAC blower and the dehumidifier are on, the dampers will energize and the dehumidifier will operate in a whole-house mode (**Figure 4**).

When the HVAC blower is off, the dampers will be de-energized and the dehumidifier will operate in a localized mode (**Figure 5**).

Note: The dampers will also be de-energized when the dehumidifier is off preventing backflow of air when only the HVAC blower is on.

FIGURE 4 – DEHUMIDIFIER OPERATING AS WHOLE-HOUSE SYSTEM

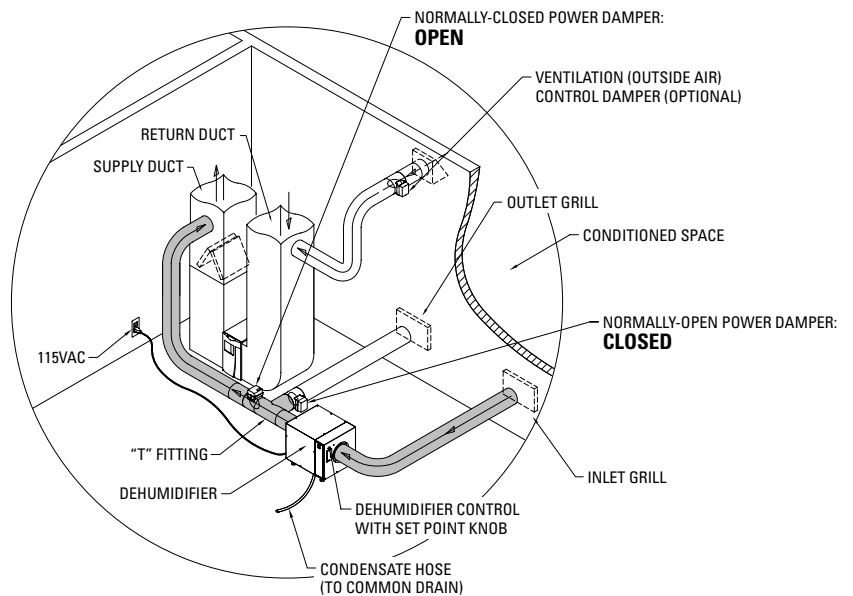

90-778

FIGURE 5 – DEHUMIDIFIER OPERATING AS LOCALIZED SYSTEM

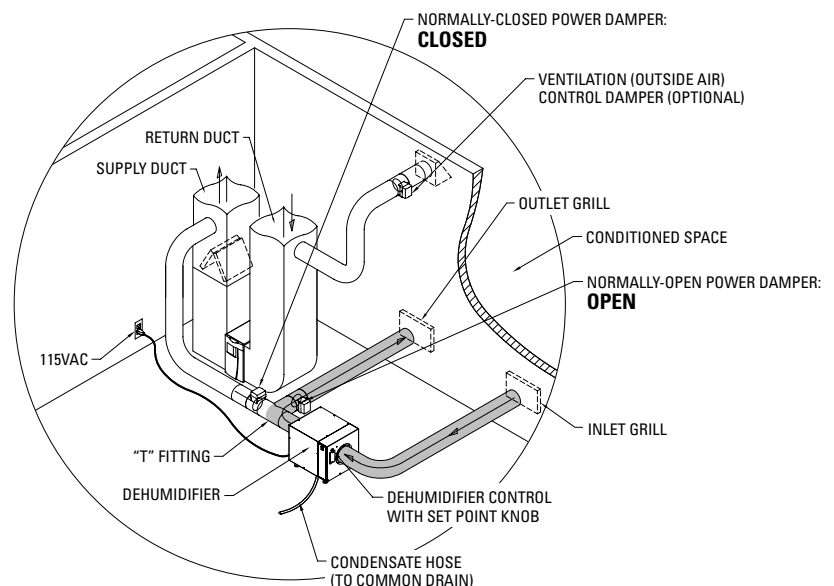

90-778

WHOLE-HOUSE, WITH LOCALIZED OPTION FOR UNCONDITIONED SPACE

This installation is used to dehumidify a whole house and also a separate unconditioned space like an unfinished basement or an area where circulation of air from that location throughout the house is undesirable. Four dampers are installed.

In whole house mode (**Figure 6**), whenever the HVAC blower turns on, air is pulled from the return duct, dehumidified, and returned to the HVAC system downstream of the cooling coil in the main supply duct.

In localized mode (**Figure 7**) the four-damper configuration cuts out the HVAC ducting and opens the ducting to the unconditioned space, pulling and returning air from this area alone. This keeps the living space and unconditioned spaces separate.

FIGURE 6 – DEHUMIDIFIER OPERATING AS WHOLE-HOUSE SYSTEM

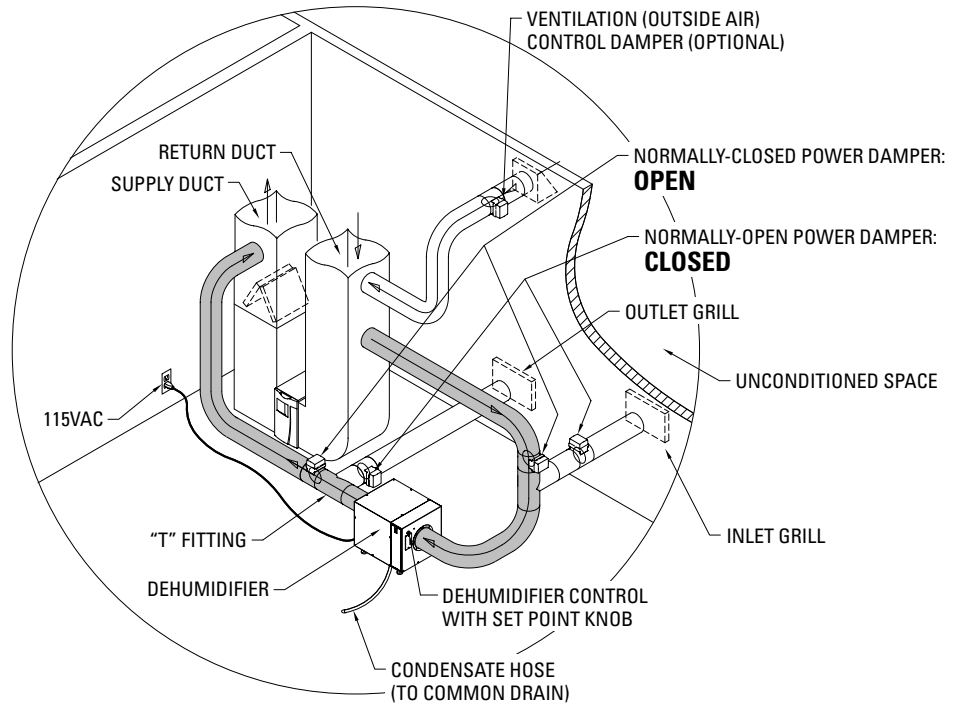

90-779

FIGURE 7 – DEHUMIDIFIER AUTOMATICALLY CONVERTED TO LOCALIZED SYSTEM

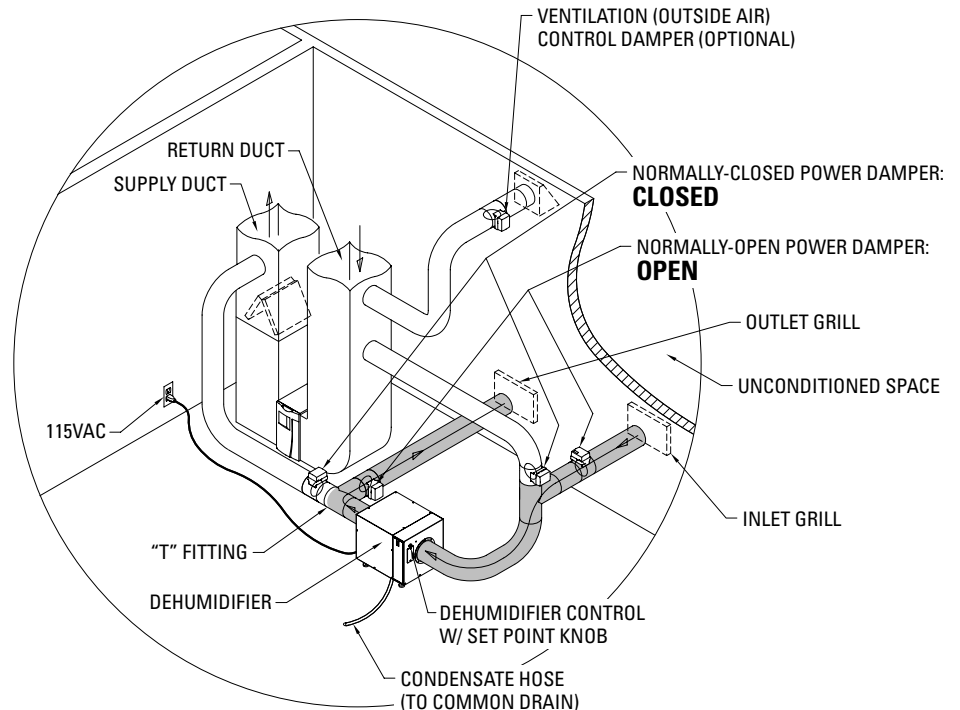

90-779

LOCATION

The dehumidifier can be installed in a wide variety of locations. It is required to be sheltered from the elements, but can operate in 40°F to 150°F ambient conditions.

- The dehumidifier is designed for a dedicated 15 amp circuit.
- Care must be taken to install the unit level.
- The condensate drain must have a trap installed. Please see **Figure 8** for drain trap recommendations. Make sure that a secure, leak-proof connection is made between the drain trap and drain elbow on the dehumidifier. The condensate hose should be sloped to a drain so water cannot back up past trap.
- There must also be clearance for removing the filter from the unit. This requires 20" on the left side of the filter door (**Figure 9**).

Note: If a condensate pump is used, the dehumidifier must be raised above the inlet so that the drain water flows freely to the pump.

HANGING

If the unit is to be hung, it must be supported from the bottom. It is recommended to use two unistruts to support the base on the outside edges of the feet locations. The strut must come out a minimum of 3" in front of the filter access panel to allow the panel to be removed. Make sure that the filter itself can still be removed.

ATTIC INSTALLATION

It is strongly recommended that the unit be placed in a drain pan with overflow protection to prevent water damage in the event of a drain failure. The condensate line should also be insulated to prevent condensation on the outside of the line.

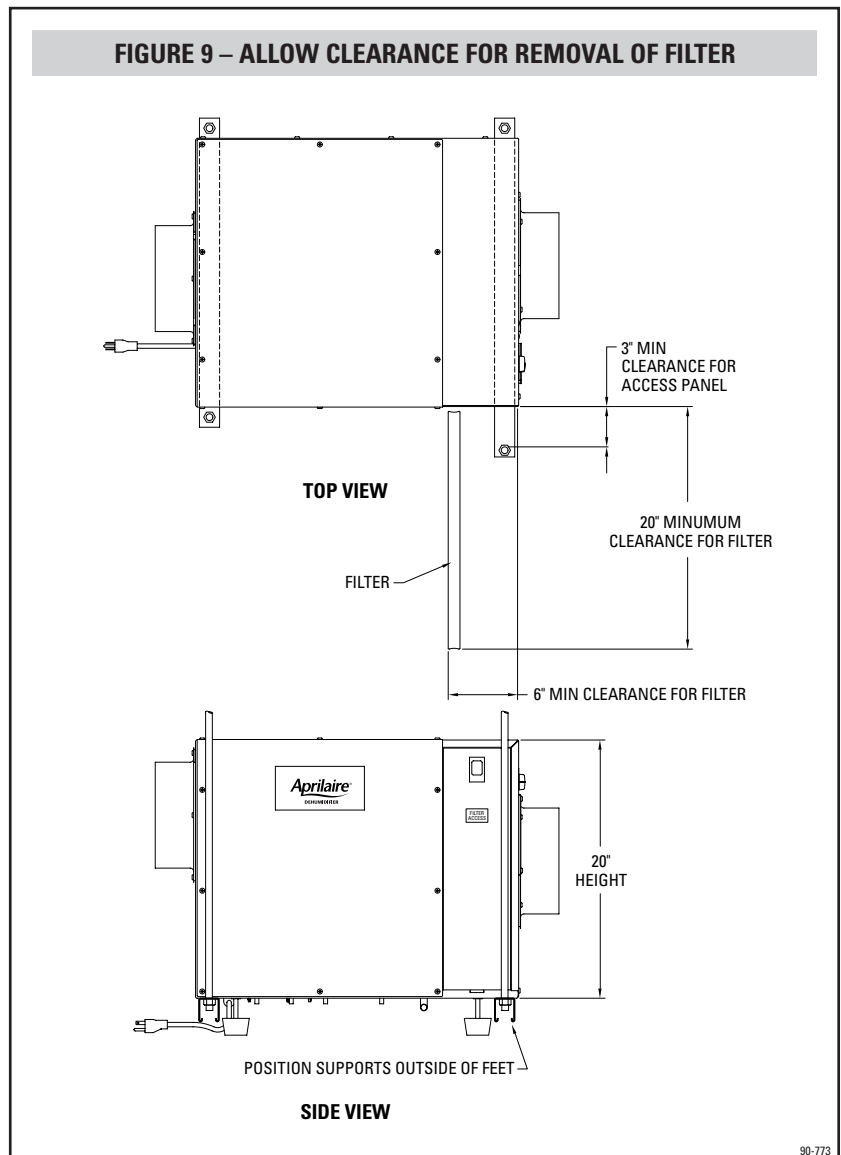
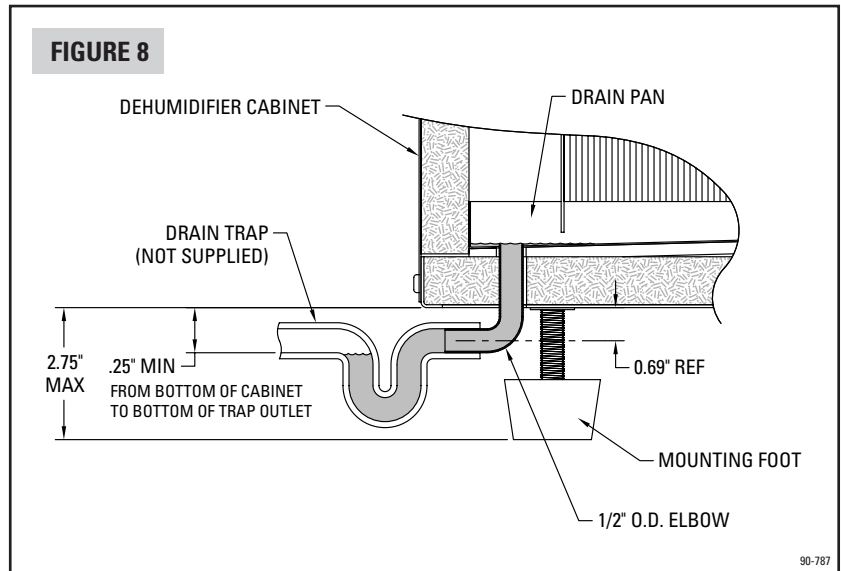

DUCTING

INSTALLING DUCT COLLARS

The Aprilaire® Dehumidifier is supplied with two, 8” round collars for connecting to the inlet and outlet of the dehumidifier. They are packaged inside the unit behind the filter access panel and must be removed. To install a collar, center it over the opening and allow the foam seal to uniformly contact the dehumidifier. Secure with 4 galvanized sheet metal screws (not included).

Note: Use the collars supplied with the dehumidifier. Do not install reducers or restrict the inlet or outlet of the dehumidifier; this may cause problems with the operation of the dehumidifier.

DUCTWORK

UL approved 8” diameter, insulated, flexible duct is recommended for connecting to the dehumidifier. The flexible duct should be capable of handling at least 0.75” of negative and 2” of positive static pressure. Additionally, the flexible duct should meet and be installed to meet all local codes and requirements for ductwork.

The duct should be installed in general accordance with SMACNA HVAC Duct Construction Standard-Metal & Flexible Duct, “Seal Class A” regardless of the operating pressures. The operation of the dehumidifier is controlled based on the conditions of the inlet air to the dehumidifier. Therefore, leakage at the inlet collar is particularly important to eliminate.

All joints and seams must be sealed.

The “Maximum Total Equivalent Length” of 8” flexible duct that can be connected to the Aprilaire® Dehumidifier is a function of the pressures in the HVAC system. The following table can be used as a guideline for determining this.

Maximum Amount of Flex Duct in Equivalent Length (E.L.) in Dehumidifier System at Listed Plenum Static Pressure Drop (ΔP)			
Plenum Static ΔP	Maximum Amount of Flex Duct in E.L.	Total Flex Duct Length	Total Number 90° Elbows
”w.c.	ft	ft	#
≤ 0.4	240	230	2
		220	4
		210	6
		200	8
0.50	150	140	2
		130	4
		120	6
		110	8
0.60	60	50	2
		40	4
		30	6
		20	8

Example:

A system with 0.5” w.c. static ΔP and (4) 90° elbows would be able to use a maximum of 130 feet of flex duct.

Notes:

1. The dehumidifier system's air leakage is considered to be Zero.
2. The Equivalent Length (E.L.) for one 90° elbow is 5 feet.
3. The E.L. is based on a “Minimum Allowable Airflow” of 175 CFM with a dirty air filter and 210 CFM with a clean air filter.
4. Equivalent duct includes both the dehumidifier inlet and outlet ducts.
5. If the difference between “HVAC Supply Static Pressure” and the “HVAC Return Static Pressure” exceeds 0.80” w.c., the dehumidifier should not be installed.

After determining the manner or type of dehumidification system configuration that will be used, and if the duct system equivalent length is acceptable, please use the following criteria and guidelines for installing the ductwork.

- If needed, use Aprilaire® Normally-Closed Damper Model 6508 on the dehumidifier outlet. The recommended location for this damper is at least 3 feet downstream of the outlet collar. Do not use conventional back draft dampers, the pressure drop of these dampers is too high.
- The outlet from the dehumidifier to the HVAC supply duct must be located at least 6" downstream of the cooling coil.
- If the dehumidifier inlet is drawing air from the HVAC return duct, it must be located at least 6" upstream of the HVAC system air cleaner. This will prevent any trapped particulates from being drawn into the dehumidifier.
- If UV Germicidal lamps are installed in the HVAC System, use appropriate methods to protect the flexible duct from the UV light.
- **At the time of install with a new air filter, the airflow rate through the dehumidifier must exceed 210 cfm. If it does not the dehumidifier must not be installed.**
- If air noise is a problem, install at least 5 feet of acoustical flexible duct on the outlet of the dehumidifier.
- If inlet or exhaust grilles are used they must be properly sized so as not to restrict airflow. They should be sized for an airflow rate of 275 cfm.
- If a ventilation duct is used, locate the ventilation air inlet at least 3' upstream from the duct that feeds the dehumidifier inlet.
- The blower in the dehumidifier has a shutoff pressure of 1.2" w.c. Therefore, with added safety factor ductwork must be able to withstand pressure of 2" w.c.
- If tees are used in the ductwork, install them in such a manner that reduces system pressure drop.

AIR FILTER

Under normal circumstances, the air filter in the dehumidifier should be cleaned or replaced once a year. A clean filter is necessary to prevent damage to the dehumidifier and to allow the dehumidifier to function at full capacity. To remove the filter, first unplug or disconnect power to the dehumidifier, then remove the air filter via the filter access panel on the side of the dehumidifier. To clean, flush with warm water and detergent solution. After a clean or new filter (Model 4510) is reinstalled, replace the access panel and reconnect power to the dehumidifier.

WIRING

WIRE DEHUMIDIFIER TO HVAC EQUIPMENT

NOTE – When installing the dehumidifier in a system with a power-stealing thermostat, the use of load resistors on the Y and W terminals are recommended.

CAUTION

Improper wiring to the HVAC equipment could cause damage to the dehumidifier control and/or the HVAC equipment.

- Six wires are required to connect the dehumidifier to the HVAC equipment. See **Figure 10**.
- Connect wires from the R, C, W, and Y terminals on the dehumidifier to the corresponding terminals on the HVAC equipment control board.
- On the HVAC equipment control board, disconnect the G wire that comes from the thermostat and use a wire nut (not provided) to connect the G wire from the thermostat to the G_S wire on the dehumidifier.
- Connect the G_H wire from the dehumidifier to the (now open) G terminal on the HVAC equipment control board. **Note:** the only wire connected to the G terminal on the HVAC equipment control board should be the G_H wire from the dehumidifier.

FIGURE 10

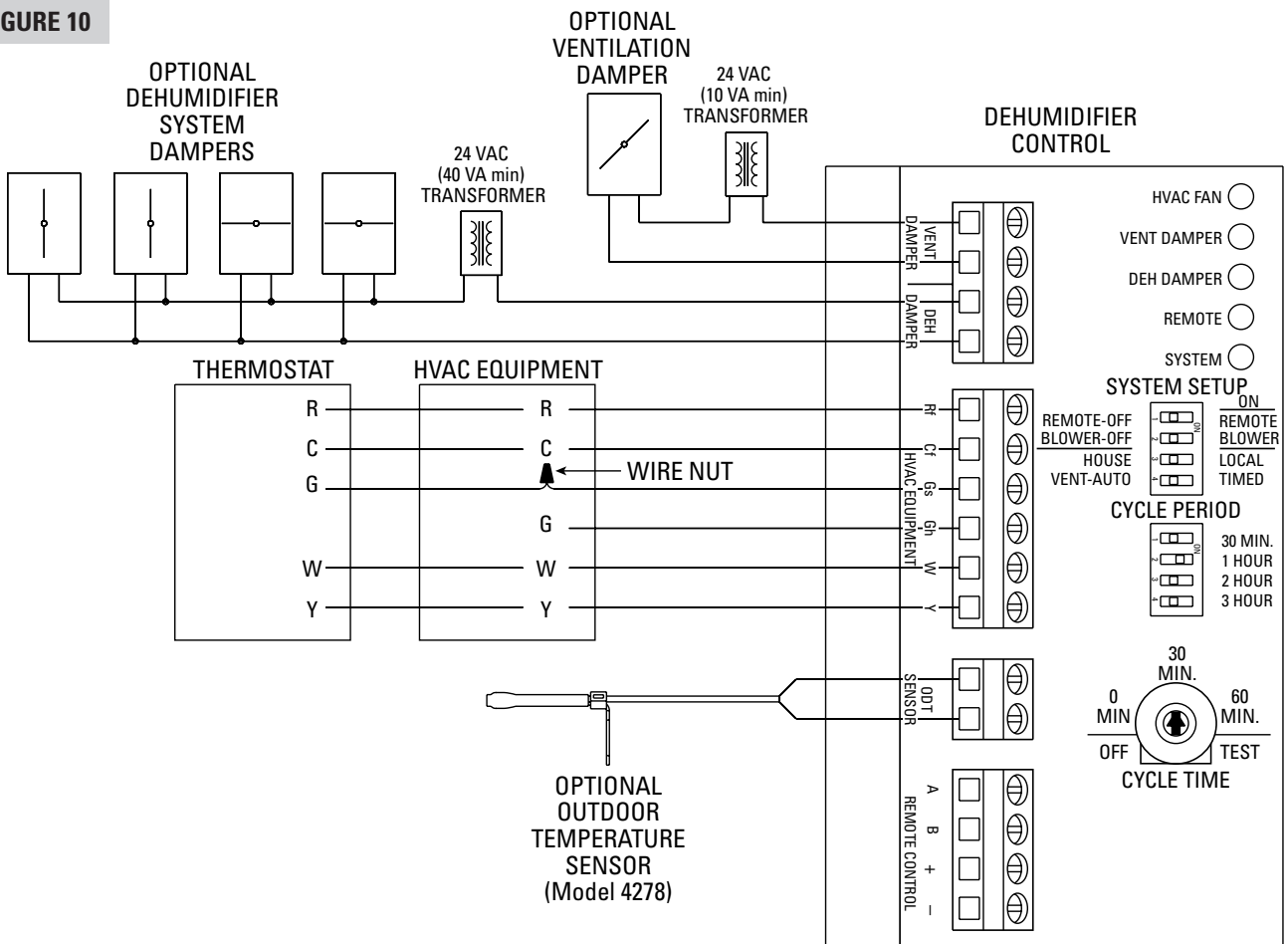

OPTIONAL VENTILATION – DAMPER AND OUTDOOR TEMPERATURE SENSOR

This installed option allows outside air to be combined with the air cycling feature from the dehumidifier, provided the outside air temperature is in the acceptable range. **Note:** The dehumidifier can control the HVAC blower to provide air cycling, regardless of whether or not an outdoor ventilation duct is installed.

- The Aprilaire® Normally-Closed Damper (Model 6506) needs to be installed in the outside air intake. It should be wired to the terminals labeled “VENT DAMPER” on the dehumidifier control board.
- In addition to these instructions, follow all installation instructions supplied with the damper.
- The Outdoor Temperature Sensor (Model 4278) can be installed outside in a shaded location (**Figure 11**) or in an outside air intake duct, but no more than 3 feet from the outside (**Figure 12**).
- The Outdoor Temperature Sensor is not affected by wire length. However, do not route the wire alongside wires carrying high voltage (115 VAC or greater), as interference may occur.
- Connect the wires from the sensor into the terminals labeled “ODT SENSOR” on the dehumidifier. See **Figure 10** for terminal locations.

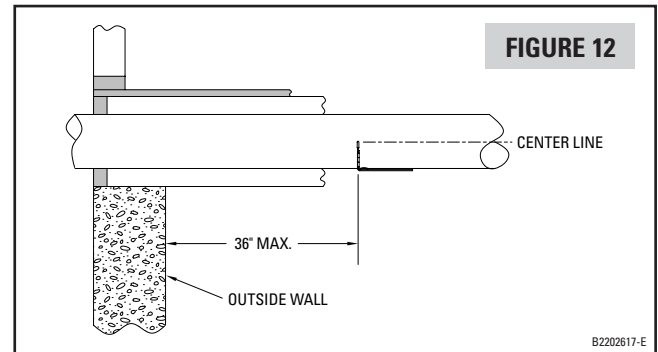
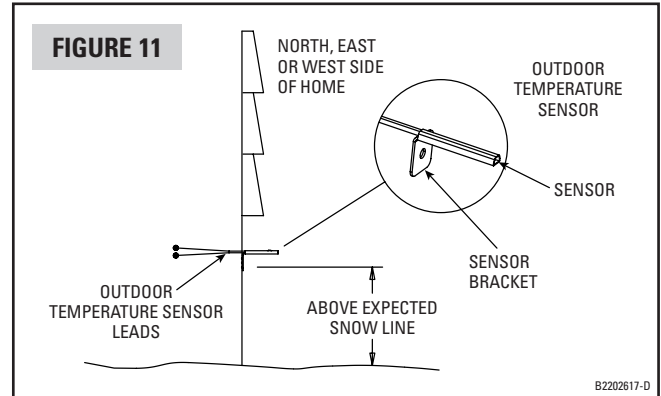

VENTILATION GUIDELINES

Air Cycling Time Setting (min./hr.)				
House Size (square feet)	Bedrooms			
	2	3	4	5
1000-1500	15	20	25	25
1501-2000	20	25	25	30
2001-2500	20	25	30	30
2501-3000	25	30	30	35
3001-3500	25	30	35	40

Notes:

1. Based on ASHRAE 62.2 ventilation requirement.
2. Based on outside air duct of 6" dia., 20' long flex duct, 0.08 in. w.c. static pressure at fresh air duct.
3. Based on 'Cycle Period' being in the default (1 hour) position.
4. A longer outside air duct and/or lower static pressure will require a longer Ventilation Time.

As an example, for a 2,500 square foot home with 3 bedrooms, set the cycle time to 25 minutes of ventilation per one-hour cycle.

A longer fresh air intake duct or lower return static pressure will increase the ventilation time required. Additionally, local codes may affect the setting.

See CONTROL AND SETUP (page 12) for setting up the cycle period and cycle time.

INSTALL AND WIRE POWERED BACKFLOW DAMPER

- If the Aprilaire® Normally-Closed Damper (Model 6508) needs to be installed in the dehumidifier outlet, it should be wired to the terminals labeled “DEH DAMPER” of the dehumidifier. In addition to these instructions, follow all installation instructions supplied with the damper.

CONTROL AND SETUP

ADJUSTING THE DEHUMIDIFIER SET POINT

Use the main control knob (**Figure 13**) on the outside of the dehumidifier to set the dryness setting. Start with a “3” or “NORMAL” setting for most installations. The homeowner can adjust the setting as needed. Moving the knob clockwise toward “7” or “MORE DRY” will decrease the dehumidifier dew point setting, thus making the unit run longer and produce dry conditions. Moving the knob toward “1” or “LESS DRY” will increase the dew point setting, allowing for higher moisture levels.

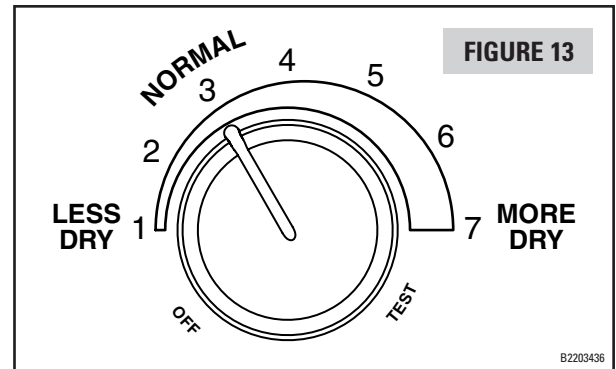

SETTING THE CONTROL OPTIONS

SYSTEM SETUP BLOCK #1

- Switch 1 – Sets Local Control or Remote Control. Default setting is “REMOTE-OFF”, Local Control.

Local Control setting activates the internal RH and temperature measuring, while Remote Control setting overrides the internal sensors with an Aprilaire remote control (Model 70 – not included).

- Switch 2 – Sets active or passive HVAC blower. Default setting is “BLOWER-OFF”, passive blower.

This controls whether or not the HVAC blower activates whenever the dehumidifier is running.

- Switch 3 – Sets whole house or localized mode. Default setting is whole “HOUSE”, mode. **Note:** If used as a convertible system, this switch needs to be placed in the “LOCAL” position.

This controls the powered dampers. In whole house mode, the dampers energize (open) whenever the dehumidifier runs. In localized mode (or convertible) dampers open when the HVAC blower and the dehumidifier are on to allow the whole house option, but the dampers close as soon as the HVAC or dehumidifier blower shuts off.

- Switch 4 – Sets automatic or timed mode for the Ventilation Controller. Default setting is “VENT-AUTO”, automatic mode.

In automatic mode, the dehumidifier will use measurements of outdoor temperature along with the user adjustable time settings to determine when to ventilate. The ventilation damper will not bring in outside air if the outside temperature is above 100°F or below 0°F. The ventilation damper will allow outside air to be brought in when the temperature is between 20°F and 0°F only during a heat call. In timed mode, outdoor air is taken based on the time setting only, regardless of temperature.

SYSTEM SETUP BLOCK #2

- Sets the cycle period for air cycling, and sets the dehumidifier cycle time (for air sampling) if air cycling is disabled. (30 minutes, 1 hour, 2 hours, or 3 hours depending on switch positions.) Default setting is 1 hour cycles. Position one switch with the desired setting to “ON”. Position the other three switches to “OFF”. **Note:** If air cycling is not desired, the cycle time potentiometer must be set to “OFF”. See next section.

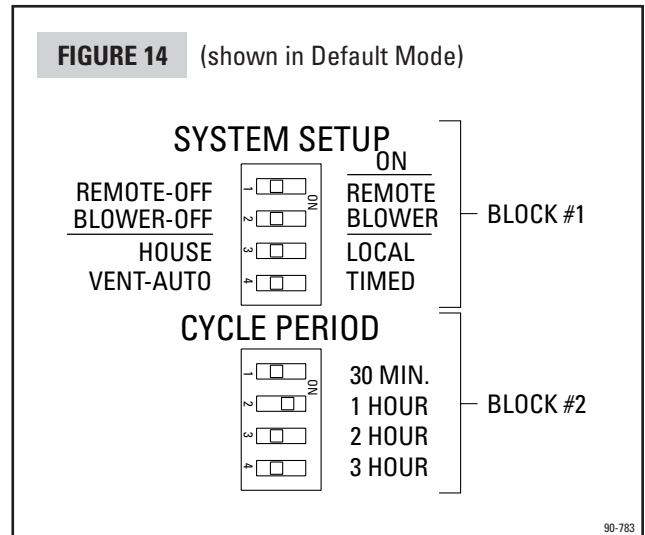

SETTING THE AIR CYCLING TIME

- The “CYCLE TIME” potentiometer on the control (**Figure 15**) is used to set the cycle time within the period you set in the previous step.
- The potentiometer settings range from “OFF” which is all the way counter-clockwise, to “TEST” which is all the way clockwise. Within those two extreme settings, the air cycling can be set from 0 to 60 minutes of air cycling time. **Here’s how this works:** If you set the cycle period to 1 hour and the cycle time potentiometer to 20 minutes, you will get 20 minutes of air cycling every hour.

FIGURE 15 (shown in Default Mode)

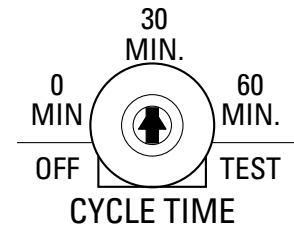

90-783

DEHUMIDIFIER SYSTEM CHECKOUT

1. Check the wiring to the HVAC equipment.
2. Rotate the main control knob clockwise to the “TEST” position.
3. If all is set up properly, the dehumidifier blower will turn on. The compressor will turn on after the dehumidifier blower has run for 30 seconds. After 1 minute the dehumidifier blower and compressor will shut off (“TEST” mode only).
4. If the dehumidifier blower does not activate in TEST mode, refer to the Troubleshooting Guide.
5. For ventilation (optional) test, be sure that 24 VAC is applied in series with the Aprilaire® Normally-Closed Damper (Model 6506) and connected to the “VENT DAMPER” terminals on the dehumidifier control.
6. Rotate the “CYCLE TIME” potentiometer clockwise to the “TEST” position.
7. If all is set up properly, the HVAC blower will turn on and the ventilation damper will open. Both should be audible to the installer. The HVAC blower will remain on and the ventilation damper will remain open for 1 minute or until the potentiometer is turned from the “TEST” position, whichever happens first.
8. If the optional ventilation damper or HVAC blower does not activate in TEST mode, refer to the Troubleshooting Guide.

TROUBLESHOOTING GUIDE

SYMPTOM

TROUBLESHOOTING PROCEDURE

The dehumidifier damper does not open in "TEST" Mode

- Follow all of the system checkout procedures.
- Check the wiring diagram for the damper & 24 VAC transformer.

The ventilation damper does not open when the HVAC blower is active.

- The damper will not open if the cycle time within the current period has already been met. For instance if the cycle time is set to 5 minutes and the control has already ventilated for 5 minutes in that interval, the damper will remain closed.
- If the outdoor temperature is below 0°F or above 100°F, the damper will remain closed for energy efficiency.
- If using the Outdoor Temperature Sensor, check that it is installed in the Fresh Air Intake a maximum of 3 feet from the outside, **or** on the North, East or West side of the house. (Not in direct sunlight.)

The fan turns on unexpectedly

- The control will turn on the fan as needed to meet the air cycling requirements determined by the cycle time and cycle period settings.

HVAC blower does not turn on when cycle time potentiometer is in "TEST" mode

- Make sure there is power to the HVAC equipment.
- Check the wiring diagram for the R, C, W, Y, G_H, and G_S at the HVAC equipment, thermostat, and the dehumidifier.
- Make sure the supplied Temperature Sensor is connected to the Outdoor Temperature Sensor terminals or the System Setup block is set to "TIMED" mode.
- Check the voltage across the R and C terminals at the dehumidifier. Voltage should be 22 VAC minimum – 30 VAC maximum.
- In "TEST" Mode, the HVAC blower will activate for 1 minute, **DO NOT LEAVE IN TEST MODE AS DEHUMIDIFIER WILL NOT OPERATE.**

Air cycling operates continuously after the potentiometer is taken off "TEST" mode

- If the HVAC equipment is making a Heat or Cool call, or the fan is in Continuous Operation, air cycling will remain on until the requirement set by the cycle period dip switch and knob is met.
- If the interval is set at 1 HOUR and the cycle time is set at 60 minutes, air cycling will be on continuously. Change the setting to a lower amount if this is not desired.

The dehumidifier does not run

- Follow all of the system checkout procedures.
- Check that the power switch on the dehumidifier is on.
- Check that the circuit breaker is not tripped. The dehumidifier requires a minimum of 9 amps. It is recommended the dehumidifier be placed on its own dedicated 15 amp circuit.



10006238
B2203431

P.O. BOX 1467 • MADISON, WI 53701-1467 • PHONE: 800/334-6011 • FAX: 608/257-4357 • www.aprilaircontractor.com