



www.Source1Parts.com

FC9C SERIES MODULATING VARIABLE SPEED CONDENSING UPFLOW NATURAL GAS FURNACES (STYLE A)

HVAC SERVICE PARTS

Supersedes: 035-21279-001 Rev. B (0108)

035-21279-001 Rev. C (0708)

1 of 8

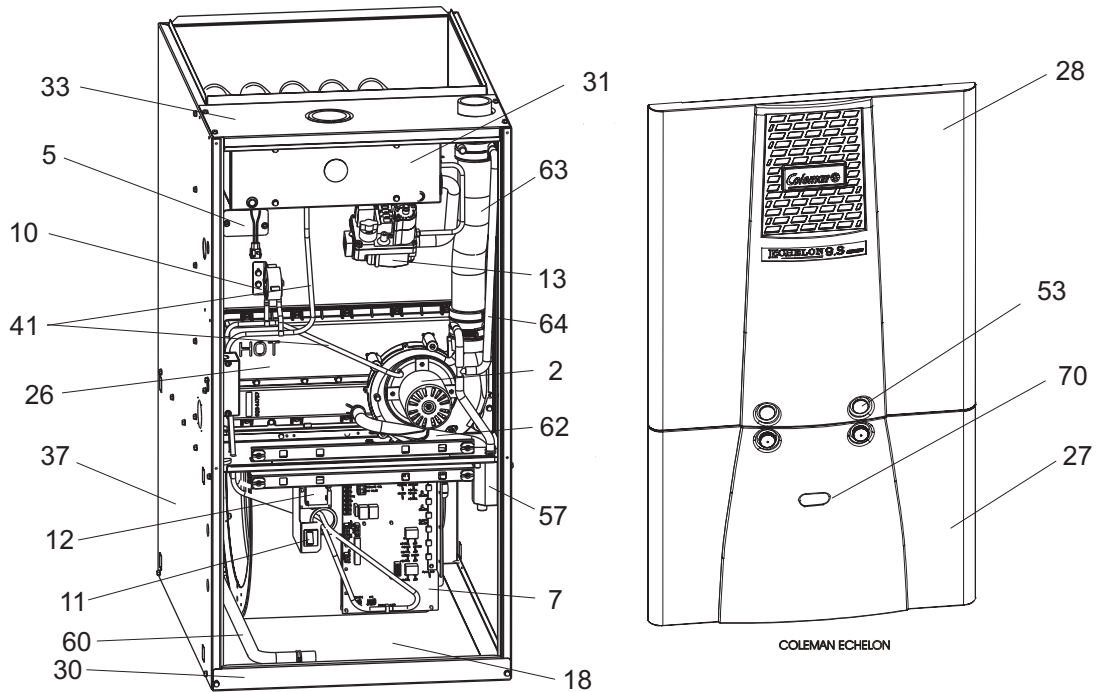

Figure 1: MODULATING VARIABLE SPEED CONDENSING UPFLOW NATURAL GAS FURNACES

FIG	ITEM	DESCRIPTION	FC9C060B12UP11A	FC9C080B12UP11A	FC9C080C16UP11A
			(3 BURNER)	(4 BURNER)	(4 BURNER)
MOTOR					
2	1	ECM PROGRAMMED MOTOR/MODULE	S1-02435352000	S1-02435352000	S1-02435353000
*	1A	ECM PROGRAMMED MODULE (only)	S1-32432013076	S1-32432013076	S1-32432014077
*	1B	ECM MOTOR (only, less ECM module)	S1-02431940000	S1-02431940000	S1-02431947000
1,2	2	MOTOR, INDUCER ASS'Y	S1-32435817000	S1-32435817000	S1-32435817000
ELECTRICAL					
	3				
2	4	SWITCH, LIMIT (INDUCER)	S1-02538737000	S1-02538737000	S1-02538737000
1	5	LIMIT, TEMPERATURE (Primary)	S1-02529041012	S1-02529041012	S1-02529041012
3	6	LIMIT, FLAME ROLL-OUT	S1-02527792001	S1-02527792001	S1-02527792001
1	7	CONTROL, FURNACE MODULATING	S1-03109153000	S1-03109153000	S1-03109153000
3	8	IGNITER	S1-02532625000	S1-02532625000	S1-02532625000
3	9	SENSOR, FLAME	S1-02537499000	S1-02537499000	S1-02537499000
1	10	SWITCH, PRESSURE	S1-02435308000	S1-02435308000	S1-02435308000
1	11	SWITCH, DOOR	S1-02427640000	S1-02427640000	S1-02427640000
1	12	TRANSFORMER	S1-02530889000	S1-02530889000	S1-02530889000
1,3	13	VALVE, GAS	S1-02538975000	S1-02538975000	S1-02538975000
2	14	SENSOR, THERMISTOR	S1-03109141000	S1-03109141000	S1-03109141000
AIR MOVING					
2	15	HOUSING, BLOWER	S1-37323724001	S1-37319812751	S1-37323746001
2	16	WHEEL, BLOWER	S1-02619654009	S1-02619654009	S1-02619654014
*	17	BRACKET, BLOWER MOUNTING (2 Req'd)	S1-07323778001	S1-07323778001	S1-07323778001

NOTE: *Not Shown

New replacement parts shown in **bold** face type at the first printing of parts list dated 7/08.

Major components and suggested stocking items are shown with shaded item number.

"<" Across from row indicates a change in that row.

--- Not applicable to specified model.



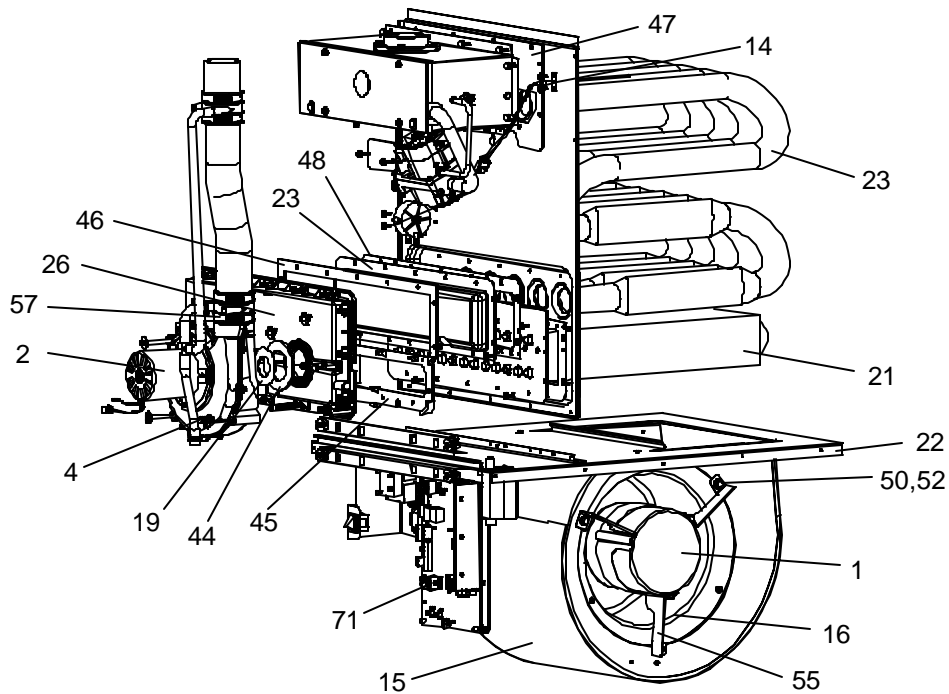

Figure 2: MODULATING VARIABLE SPEED CONDENSING UPFLOW NATURAL GAS FURNACES

FIG	ITEM	DESCRIPTION	FC9C060B12UP11A	FC9C080B12UP11A	FC9C080C16UP11A
			(3 BURNER)	(4 BURNER)	(4 BURNER)
FABRICATED PARTS					
1	18	PANEL, BLOCK-OFF	S1-07319812090	S1-07319812090	S1-07319816090
2	19	COMBUSTION BLWR RESTRICTOR	S1-02815163000	---	S1-02815164000
3	20	BURNER, MAIN GAS	S1-02920482000	S1-02920482000	S1-02920482000
2	21	COIL, CONDENSING	S1-37319812801	S1-37319812801	S1-37319816801
2	22	SHELF, BLOWER	S1-07323783001	S1-07323783001	S1-07323783002
2	23	HEAT EXCHANGER ASS'Y	S1-37323785001	S1-37323785002	S1-37323785003
3	24	MANIFOLD, GAS	S1-02922253030	S1-02922253040	S1-02922253040
2	25	SHIELD, PAN	S1-07319812560	S1-07319812560	S1-07319816560
1,2	26	CONDENSATE PAN	S1-02814756001	S1-02814756001	S1-02814757001
1	27	PANEL, BLOWER ACCESS (Magnet)	S1-37323801022	S1-37323801022	S1-37323801023
1	28	ACCESS PANEL, UPPER (Magnet)	S1-37323801058	S1-37323801058	S1-37323801059
3	29	WRAPPER, BURNER BOX	S1-07319811030	S1-07319811040	S1-07319811040
1	30	CHANNEL, TOE PLATE	S1-07319862052	S1-07319862052	S1-07319862053
1,3	31	COVER, GAS CONTROL	S1-37322155002	S1-37322155003	S1-37322155003
3	32	BOTTOM PANEL, BURNER BOX	S1-07319811130	S1-07319811140	S1-07319811140
1	33	PANEL, TOP	S1-07323753003	S1-07323753003	S1-07323753004
3	34	SUPPORT, BURNER	S1-07319811330	S1-07319811340	S1-07319811340
1	35	PLATE, DIFFUSER	S1-07314566002	S1-07314566003	S1-07314566003
3	36	BRACKET, IGNITER	S1-07317403000	S1-07317403000	S1-07317403000
1	37	WRAPPER, INSULATED	S1-37319812141	S1-37319812141	S1-37319816141
	38				

NOTE: *Not Shown
 New replacement parts shown in **bold** face type at the first printing of parts list dated 7/08.
 Major components and suggested stocking items are shown with shaded item number.
 "<" Across from row indicates a change in that row.
 --- Not applicable to specified model.

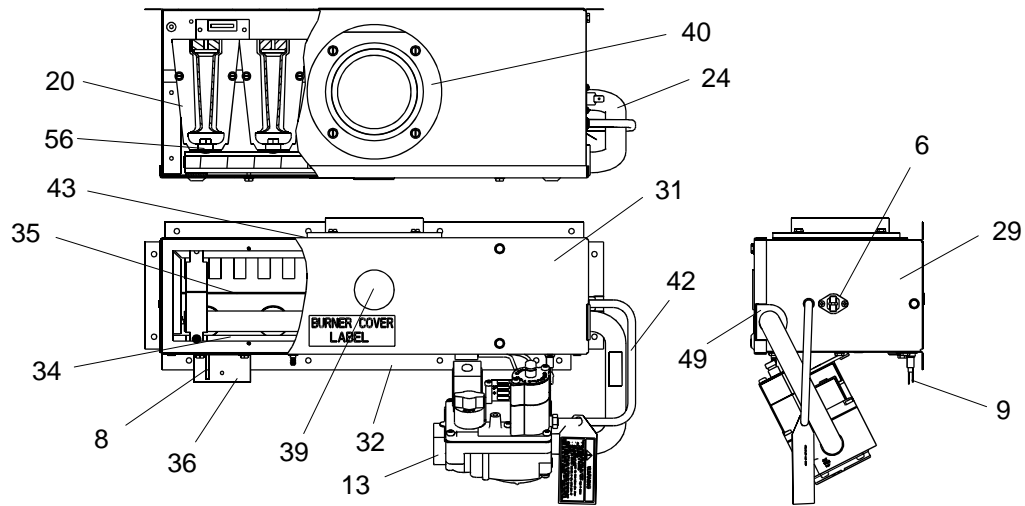

Figure 3: GAS CONTROLS

FIG	ITEM	DESCRIPTION	FC9C060B12UP11A	FC9C080B12UP11A	FC9C080C16UP11A
			(3 BURNER)	(4 BURNER)	(4 BURNER)
MISCELLANEOUS					
3	39	PLUG, WINDOW, CLEAR -1.5"	S1-02537005000	S1-02537005000	S1-02537005000
3	40	CONNECTOR AIR INTAKE 2"	S1-02811289000	S1-02811289000	S1-02811289000
1	41	HOSE ASSEMBLY, VACUM (2 Req'd)	S1-02815235000	S1-02815235000	S1-02815235000
1,3	42	TUBING, PREFORMED	S1-02815170000	S1-02815170000	S1-02815170000
3	43	GASKET, AIR INTAKE	S1-02812460001	S1-02812460001	S1-02812460001
2	44	GASKET, COMBUSTION BLOWER	S1-02814767000	S1-02814767000	S1-02814767000
2	45	GASKET, CONDENSATE PAN	S1-02814759002	S1-02814759002	S1-02814759003
2	46	GASKET, UPPER CONDENSATE PAN	S1-02814773000	S1-02814773000	S1-02814774000
2	47	GASKET, GAS CONTROLS	S1-02815222000	S1-02815222000	S1-02815223000
2	48	GASKET (COND. COIL/LOWER PAN) (2 Req'd)	S1-02814760002	S1-02814760002	S1-02814760002
3	49	GROMMET, MANIFOLD SEAL	S1-02812465000	S1-02812465000	S1-02812465000
2	50	GROMMET, MOTOR (3 Req'd)	S1-02814740000	S1-02814740000	S1-02814740000
*	51	GROMMET, 1/2" DIA.	S1-02530823000	S1-02530823000	S1-02530823000
2	52	FERRULE, MOTOR MOUNT(3 Req'd)	S1-02320541000	S1-02320541000	S1-02320541000
1	53	DOOR KNOB, RED (4 Req'd) (Magnet)	S1-02924411000	S1-02924411000	S1-02924411000
*	54	HARNESS, MAIN WIRING	S1-02538976000	S1-02538976000	S1-02538976000
2	55	MOUNT, 1 PC. MOTOR	S1-07319831001	S1-07319831001	S1-07319831001
3	56	ORIFICE, BURNER (Natural #45)	S1-02921182045	S1-02921182045	S1-02921182045
1	57	TRAP, CONDENSATE	S1-02814762000	S1-02814762000	S1-02814762000
*	58	WIRING DIAGRAM	172111	172111	172111
2	59	DRAIN ASSY, INDUCER EXHAUST	S1-02815229000	S1-02815229000	S1-02815229000
1	60	DRAIN TUBE, CONDENSATE TRAP	S1-02813309004	S1-02813309004	S1-02813309004
1	61	DRAIN TUBE, COMBUSTION BLOWER	S1-02814764000	S1-02814764000	S1-02814764000
1	62	DRAIN TUBE, CONDENSATE PAN	S1-02814763000	S1-02814763000	S1-02814763000
1	63	VENT TUBE	S1-02815226000	S1-02815226000	S1-02815226000
1	64	DRAIN ASSY, DOUBLE GUTTER	S1-02815227000	S1-02815227000	S1-02815227000
*	65	LOCKNUT, CONDUIT (1/2")	S1-02532683000	S1-02532683000	S1-02532683000
*	66	ADAPTER, INSERT	S1-02531808000	S1-02531808000	S1-02531808000
*	67	BUSHING, THREADED	S1-02531807000	S1-02531807000	S1-02531807000
*	68	WASHER, FLAT FIBERGLASS (2 Req'd)	S1-02814768000	S1-02814768000	S1-02814768000
*	69	2" PVC	S1-02815228000	S1-02815228000	S1-02815228000
1	70	SIGHT GLASS, OVAL	S1-02538899000	S1-02538899000	S1-02538899000
2	71	JUMPER PLUG	S1-02539853000	S1-02538977000	S1-02538978000
*	72	INSERT, SILICONE	S1-02815455000	S1-02815455000	S1-02815456000
*	73	MAGNET, DOOR (4 Req'd)	S1-02924413000	S1-02924413000	S1-02924413000
*	74	HARNESS, CONTROL (16 Pin)	S1-02435351000	S1-02435351000	S1-02435351000
*	75	HARNESS, POWER (5 Pin)	S1-02435350000	S1-02435350000	S1-02435350000

NOTE: *Not Shown
 New replacement parts shown in **bold** face type at the first printing of parts list dated 7/08.
 Major components and suggested stocking items are shown with shaded item number.
 "<" Across from row indicates a change in that row.
 --- Not applicable to specified model.



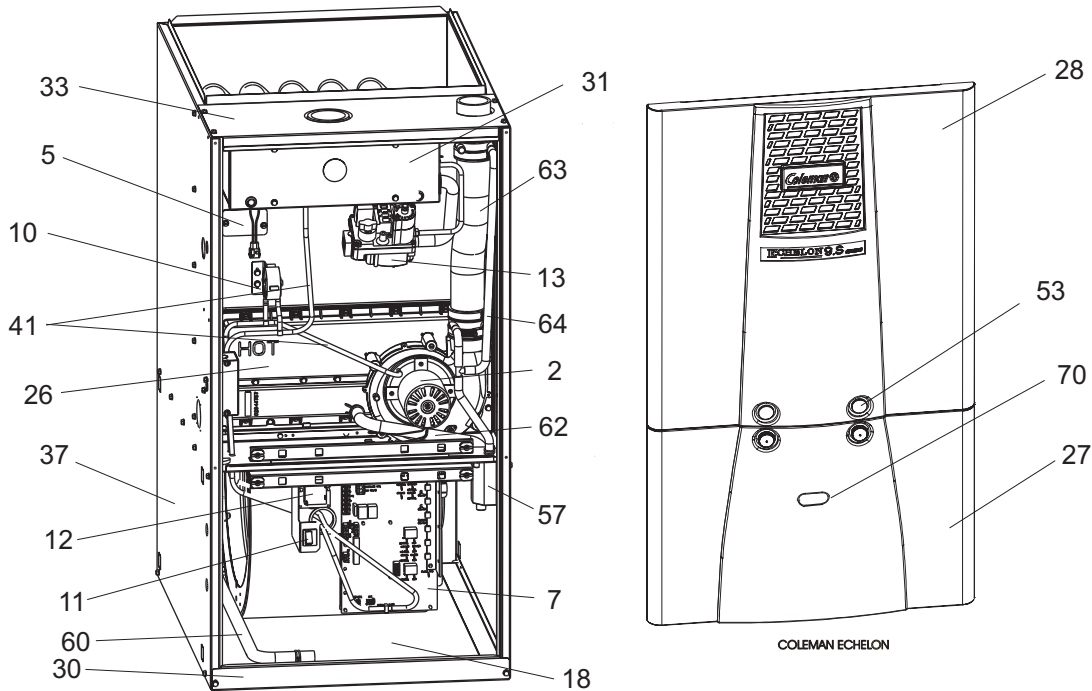

Figure 1: MODULATING VARIABLE SPEED CONDENSING UPFLOW NATURAL GAS FURNACES

FIG	ITEM	DESCRIPTION	FC9C100C16UP11A	FC9C100C20UP11A	FC9C120D20UP11A
			(5 BURNER)	(5 BURNER)	(6 BURNER)
MOTOR					
2	1	ECM PROGRAMMED MOTOR/MODULE	S1-02435353000	S1-02435354000	S1-02435354000
*	1A	ECM PROGRAMMED MODULE (only)	S1-32432014077	S1-32432015078	S1-32432015078
*	1B	ECM MOTOR (only, less ECM module)	S1-02431947000	S1-02431941000	S1-02431941000
1,2	2	MOTOR, INDUCER ASS'Y	S1-32435817000	S1-32435817000	S1-32435817000
ELECTRICAL					
	3				
2	4	SWITCH, LIMIT (INDUCER)	S1-02538737000	S1-02538737000	S1-02538737000
1	5	LIMIT, TEMPERATURE (Primary)	S1-02529041001	S1-02529041012	S1-02529041001
3	6	LIMIT, FLAME ROLL-OUT	S1-02527792001	S1-02527792001	S1-02527792001
1	7	CONTROL, MODULATING	S1-03109153000	S1-03109153000	S1-03109153000
3	8	IGNITER	S1-02532625000	S1-02532625000	S1-02532625000
3	9	SENSOR, FLAME	S1-02537499000	S1-02537499000	S1-02537499000
1	10	SWITCH, PRESSURE	S1-02435308000	S1-02435308000	S1-02435308000
1	11	SWITCH, DOOR	S1-02427640000	S1-02427640000	S1-02427640000
1	12	TRANSFORMER	S1-02530889000	S1-02530889000	S1-02530889000
1,3	13	VALVE, GAS	S1-02538975000	S1-02538975000	S1-02538975000
2	14	SENSOR, THERMISTOR	S1-03109141000	S1-03109141000	S1-03109141000
AIR MOVING					
2	15	HOUSING, BLOWER	S1-37323746001	S1-37323747001	S1-37323746001
2	16	WHEEL, BLOWER	S1-02619654014	S1-02638510000	S1-02638510000
*	17	BRACKET, BLOWER MOUNTING (2 Req'd)	S1-07323778001	S1-07323778001	S1-07323778001

NOTE: *Not Shown
 New replacement parts shown in **bold** face type at the first printing of parts list code dated 7/087.
 Major components and suggested stocking items are shown with shaded item number.
 “<” Across from row indicates a change in that row.
 --- Not applicable to specified model.

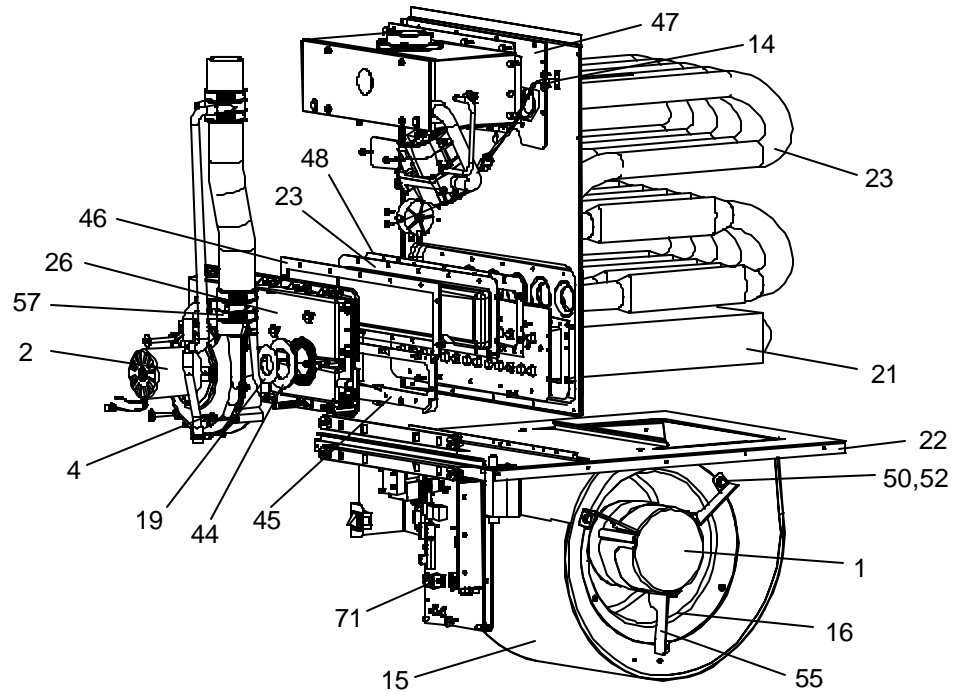

Figure 2: MODULATING VARIABLE SPEED CONDENSING UPFLOW NATURAL GAS FURNACES

FIG	ITEM	DESCRIPTION	FC9C100C16UP11A	FC9C100C20UP11A	FC9C120D20UP11A
			(5 BURNER)	(5 BURNER)	(6 BURNER)
FABRICATED PARTS					
1	18	PANEL, BLOCK-OFF	S1-07319816090	S1-07319816090	S1-07319820090
2	19	COMBUSTION BLWR RESTRICTOR	---	---	---
3	20	BURNER, MAIN GAS	S1-02920482000	S1-02920482000	S1-02920482000
2	21	COIL, CONDENSING	S1-37319816801	S1-37319816801	S1-37319820801
2	22	SHELF, BLOWER	S1-07323783002	S1-07323783003	S1-07323783004
2	23	HEAT EXCHANGER ASS'Y	S1-37323784004	S1-37323784004	S1-37323784005
3	24	MANIFOLD, GAS	S1-02922253050	S1-02922253050	S1-02922253060
2	25	SHIELD, PAN	S1-07319816560	S1-07319816560	S1-07319820560
1,2	26	CONDENSATE PAN	S1-02814757001	S1-02814757001	S1-02814758002
1	27	PANEL, BLOWER ACCESS (Magnet)	S1-37323801023	S1-37323801023	S1-37323801024
1	28	ACCESS PANEL, UPPER (Magnet)	S1-37323801059	S1-37323801059	S1-37323801060
3	29	WRAPPER, BURNER BOX	S1-07319811050	S1-07319811050	S1-07319811060
1	30	CHANNEL, TOE PLATE	S1-07319862053	S1-07319862053	S1-07319862054
1,3	31	COVER, GAS CONTROL	S1-37322155004	S1-37322155004	S1-37322155005
3	32	BOTTOM PANEL, BURNER BOX	S1-07319811150	S1-07319811150	S1-07319811160
1	33	PANEL, TOP	S1-07323753005	S1-07323753005	S1-07319815086
3	34	SUPPORT, BURNER	S1-07319811340	S1-07319811350	S1-07319811360
1	35	PLATE, DIFFUSER	S1-07314566003	S1-07314566004	S1-07314566005
3	36	BRACKET, IGNITER	S1-07317403000	S1-07317403000	S1-07317403000
1	37	WRAPPER, INSULATED	S1-37319816141	S1-37319816141	S1-37319820141
	38				

NOTE: *Not Shown
 New replacement parts shown in **bold** face type at the first printing of parts list dated 7/08.
 Major components and suggested stocking items are shown with shaded item number.
 "<" Across from row indicates a change in that row.
 --- Not applicable to specified model.



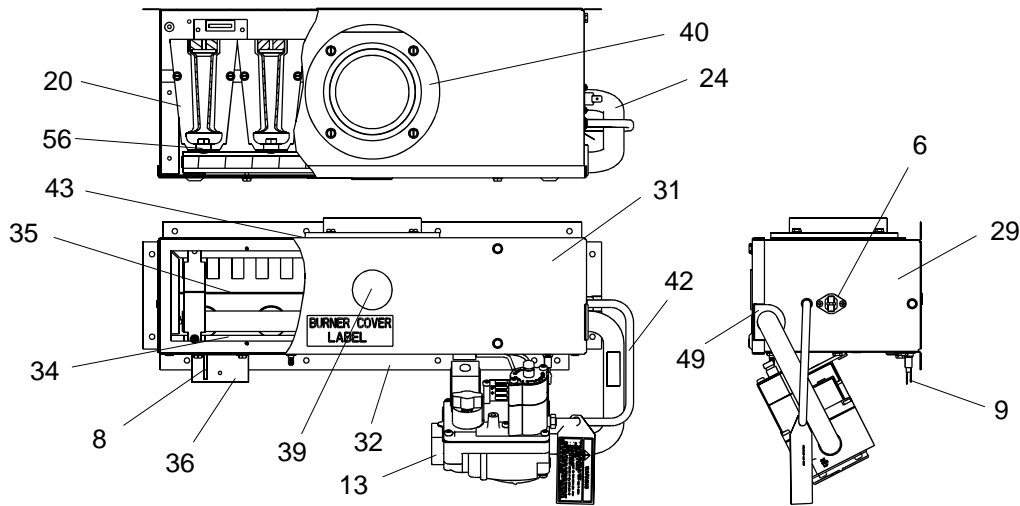

Figure 3: GAS CONTROLS

FIG	ITEM	DESCRIPTION	FC9C100C16UP11A	FC9C100C20UP11A	FC9C120D20UP11A
			(5 BURNER)	(5 BURNER)	(6 BURNER)
MISCELLANEOUS					
3	39	PLUG, WINDOW, CLEAR -1.5"	S1-02537005000	S1-02537005000	S1-02537005000
3	40	CONNECTOR AIR INTAKE 2"	S1-02811289000	S1-02811289000	S1-02811290000
1	41	HOSE ASSEMBLY, VACUM (2 Req'd)	S1-02815235000	S1-02815235000	S1-02815235000
1,3	42	TUBING, PREFORMED	S1-02815170000	S1-02815170000	S1-02815170000
3	43	GASKET, AIR INTAKE	S1-02812460001	S1-02812460001	S1-02812460002
2	44	GASKET, COMBUSTION BLOWER	S1-02814767000	S1-02814767000	S1-02814767000
2	45	GASKET, CONDENSATE PAN	S1-02814759003	S1-02814759003	S1-02814759004
2	46	GASKET, UPPER CONDENSATE PAN	S1-02814774000	S1-02814774000	S1-02814775000
2	47	GASKET, GAS CONTROLS	S1-02815224000	S1-02815224000	S1-02815223000
2	48	GASKET (COND. COIL/LOWER PAN) (2 Req'd)	S1-02814760003	S1-02814760003	S1-02814760004
3	49	GROMMET, MANIFOLD SEAL	S1-02812465000	S1-02812465000	S1-02812465000
2	50	GROMMET, MOTOR (3 Req'd)	S1-02814740000	S1-02814740000	S1-02814740000
*	51	GROMMET, 1/2" DIA.	S1-02530823000	S1-02530823000	S1-02530823000
2	52	FERRULE, MOTOR MOUNT(3 Req'd)	S1-02320541000	S1-02320541000	S1-02320541000
1	53	DOOR KNOB, RED (4 Req'd) (Magnet)	S1-02924411000	S1-02924411000	S1-02924411000
*	54	HARNESS, MAIN WIRING	S1-02538976000	S1-02538976000	S1-02538976000
2	55	MOUNT, 1 PC. MOTOR	S1-07319831001	S1-07319831001	S1-07319831001
3	56	ORIFICE, BURNER (Natural #45)	S1-02921182045	S1-02921182045	S1-02921182045
1	57	TRAP, CONDENSATE	S1-02814762000	S1-02814762000	S1-02814762000
*	58	WIRING DIAGRAM	172111	172111	172111
2	59	DRAIN ASSY, INDUCER EXHAUST	S1-02815229000	S1-02815229000	S1-02815229000
1	60	DRAIN TUBE, CONDENSATE TRAP	S1-02813309004	S1-02813309004	S1-02813309004
*	61	DRAIN TUBE, COMBUSTION BLOWER	S1-02814764000	S1-02814764000	S1-02814764000
1	62	DRAIN TUBE, CONDENSATE PAN	S1-02814763000	S1-02814763000	S1-02814763000
1	63	VENT TUBE	S1-02815226000	S1-02815226000	S1-02815226000
1	64	DRAIN ASSY, DOUBLE GUTTER	S1-02815227000	S1-02815227000	S1-02815227000
*	65	LOCKNUT, CONDUIT (1/2")	S1-02532683000	S1-02532683000	S1-02532683000
*	66	ADAPTER, INSERT	S1-02531808000	S1-02531808000	S1-02531808000
*	67	BUSHING, THREADED	S1-02531807000	S1-02531807000	S1-02531807000
*	68	WASHER, FLAT FIBERGLASS (2 Req'd)	S1-02814768000	S1-02814768000	S1-02814768000
*	69	2" PVC	S1-02815228000	S1-02815228000	S1-02815228000
*	70	SIGHT GLASS, OVAL	S1-02538899000	S1-02538899000	S1-02538899000
2	71	JUMPER PLUG	S1-02538977000	S1-02538977000	S1-02538977000
*	72	INSERT, SILICONE	S1-02815456000	S1-02815456000	S1-02815457000
*	73	MAGNET, DOOR (4 Req'd)	S1-02924413000	S1-02924413000	S1-02924413000
*	74	HARNESS, CONTROL (16 Pin)	S1-02435351000	S1-02435351000	S1-02435351000
*	75	HARNESS, POWER (5 Pin)	S1-02435350000	S1-02435350000	S1-02435350000

NOTE: *Not Shown
 New replacement parts shown in **bold** face type at the first printing of parts list dated 7/08.
 Major components and suggested stocking items are shown with shaded item number.
 "<" Across from row indicates a change in that row.
 --- Not applicable to specified model.

NOTES

TO ORDER AUTHORIZED FACTORY REPLACEMENT PARTS - Contact your Source1 HVAC Parts Distributor or visit our website at **www.Source1Parts.com** for a Distributor and Dealer listing.

Subject to change without notice. Printed in U.S.A.
Copyright © 2008 by Johnson Controls, Inc. All rights reserved.

035-21279-001 Rev. C (0708)
Supersedes: 035-21279-001 Rev. B (0108)

Johnson Controls Unitary Products
5005 York Drive
Norman, OK 73069