

Split System Heat Pump

13
seer

Form No. D13HPD-100 (11/2010)

13HPD Features and Benefits

- Nitrogen charged for replacement of R22 components only
- High-quality condenser coil with copper tubing and enhanced louvered fin for maximum heat transfer capacity
- Top discharge directs hot air and sound away from living area and shrubbery
- All units run tested
- Available with wire guard coil protection
- Easy access to electrical panels, pre-wired for easy hook-up
- Bi-directional liquid line filter drier factory installed
- Discharge muffler for quiet operation
- Reliable, solid state time/temperature defrost control, with field selectable 30/60/90 minute intervals
- Defrost control is Quiet Shift[™] capable
- Integrated control with LED diagnostics
- Short cycle protection factory installed
- All units UL and ULC approved



WARRANTY

- 5 year limited warranty on compressor, 5 year limited warranty on all parts

Model Number Guide

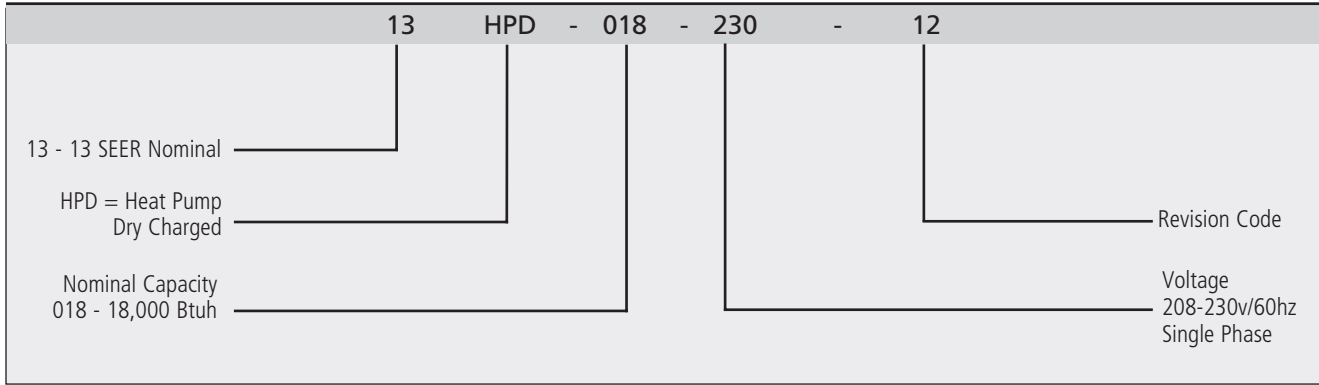

Electrical and Physical Data

Model	Voltage/ Hz/ Phase	Voltage Range	Min. Circuit (Amps)	Max. Fuse (Amps)	Compressor		Fan Motor			Field Supplied R22 Charge (oz.)	Shipping Weight (lbs)
					Rated Load (Amps)	Locked Rotor (Amps)	Full Load (Amps)	Rated HP	Nom. RPM		
13HPD018	208-230/60/1	197-253	12.3	20	8.9	41	1.1	1/5	1075	102	130
13HPD024	208-230/60/1	197-253	14.0	20	10.3	56	1.1	1/5	1075	99	144
13HPD030	208-230/60/1	197-253	18.0	30	13.5	72.5	1.1	1/5	1075	132	162
13HPD036	208-230/60/1	197-253	19.4	30	14.7	83	1.1	1/5	1075	138	170
13HPD042	208-230/60/1	197-253	22.9	40	17	95	1.7	1/3	1075	166	200
13HPD048	208-230/60/1	197-253	25.7	45	19.2	129	1.7	1/3	1075	188	237
13HPD060	208-230/60/1	197-253	34.3	60	26	148	1.7	1/3	825	224	270

Note:
Weights listed are unit weights with packaging
Units are factory shipped with dry nitrogen holding charge

Unit Dimensions & Sound Ratings

Model	Dimensions			Sound Ratings (dBa)
	A - width (in.)	B - depth (in.)	C - height (in.)	
13HPD018	26.75	26.25	33.50	76
13HPD024	26.75	26.25	33.50	76
13HPD030	26.75	26.25	29.50	76
13HPD036	26.75	26.25	33.50	76
13HPD042	30.75	30.25	33.50	80
13HPD048	30.75	30.25	37.50	80
13HPD060	34.75	34.25	37.50	80

Note: Dimensions listed are unit sizes w/o packaging

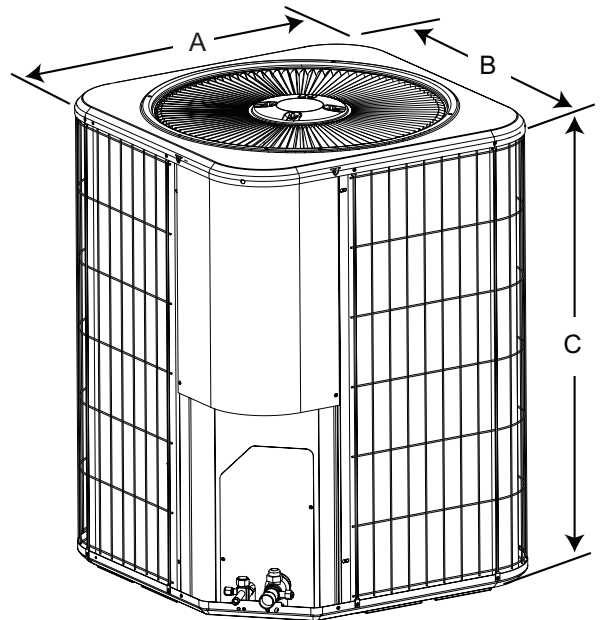

Cooling Performance with Air Handlers

Outdoor Model	Indoor Model	Cooling				Heating				CFM	Refrigerant Connection				Refrig. Line Size		Indoor Expansion Device	
		Air Handlers	SEER	EER	Rated Capacity BTUH	Sensible Capacity BTUH	HSPF	47			17		Outdoor		Indoor			Suction
	Btuh							COP	Btuh		COP	Suction	Liquid	Suction	Liquid			
13HPD018	BCS2M18C****P+TXV	13.0	11.5	18,600	14,100	7.7	16,700	3.4	10,500	2.3	600	3/4	3/8	3/4	3/8	3/4	3/8	H2TXV01
13HPD024	BCS2M24C****P+TXV	13.0	11.5	24,600	18,700	7.7	22,000	3.4	13,800	2.3	800	3/4	3/8	3/4	3/8	3/4	3/8	H2TXV01
13HPD030	BCS2M30C****P+TXV	13.0	11.0	31,000	23,500	7.7	28,600	3.5	17,900	2.4	1000	3/4	3/8	3/4	3/8	3/4	3/8	H2TXV01
13HPD036	BCS2M36C****P+TXV	13.0	11.0	35,200	27,100	7.7	33,800	3.5	21,000	2.4	1200	7/8	3/8	3/4	3/8	7/8	3/8	H2TXV01
13HPD042	BCS2M42C****P+TXV	13.0	11.0	41,500	32,300	7.7	41,000	3.3	23,500	2.3	1400	7/8	3/8	7/8	3/8	7/8	3/8	H2TXV02
13HPD048	BCS2M48C****P+TXV	13.0	11.0	50,500	38,400	7.7	47,500	3.3	30,100	2.4	1600	7/8	3/8	7/8	3/8	7/8	3/8	H2TXV02
13HPD060	BCS2M60C****P+TXV	13.0	11.0	57,000	42,800	7.7	55,500	3.3	35,700	2.4	1800	1-1/8	3/8	7/8	3/8	1-1/8	3/8	H2TXV03

Note:
EPA rules prohibit system installations (condensing unit coupled with an air handler or evaporator coil).

Accessories

Kit Number	Description	Used with
58M81	Blower Off Delay Kit	All 13HPD's
45F08	Compressor Low Ambient Cut-off	All 13HPD's
94J46	High Pressure Switch Kit	All 13HPD's
47J27	Compressor Time-off Control	All 13HPD's
93M05	Crank Case Heater	All 13HPD's
10J42	Hard Start Kit 1-1/2, 2, 2-1/2 & 3-1/2 Tons	13HPD 18, 24, 30, 36, & 42
81J69	Hard Start Kit 4 & 5 Tons	13HPD 48 & 60
33M07	Mild Ambient Kit	All 13HPD's
27J00	Low Ambient Kit	All 13HPD's
84M23	Loss of Charge Kit	All 13HPD's
93G35	Freezestats (3/8" tubing)	All 13HPD's
50A93	Freezestats (5/8" tubing)	All 13HPD's
H2TX01	TXV Kit	13HPD 18, 24 & 30
H2TX02	TXV Kit	13HPD 36, 42 & 48
H2TX03	TXV Kit	13HPD 60

13
seer

HPD Split System Heat Pump

All specifications and illustrations
subject to change without notice
and without incurring obligations.

DucaneTM
**AIR CONDITIONING
AND HEATING**

www.ducanehvac.com
1-800-448-5872

