

# INSTALLATION INSTRUCTIONS

## LUF, LHF, LBF, LBR, & LHR

### Oil-Fired Furnaces

Save these instructions for future reference

#### **WARNING**

Improper installation, adjustment, alteration, service, or maintenance can cause injury or property damage. Refer to this manual. For assistance or additional information, consult a qualified installer or service agency.

#### **WARNING**

Do not store combustible materials, including gasoline and other flammable vapors and liquids, near the furnace, vent pipe, or warm air ducts. The homeowner should be cautioned that the furnace area must not be used as a broom closet or for any other storage purposes. Such uses may result in actions that could cause property damage, personal injury, or death.

#### **CAUTION**

Never burn garbage or paper in the heating system and never leave rags, paper, or any flammable items around the unit.

#### **WARNING**

This furnace is not approved for installation in a mobile home. Do not install this furnace in a mobile home. Installation in a mobile home could result in actions that could cause property damage, personal injury, or death.

#### **TABLE OF CONTENTS**

START-UP CHECKLIST .....	2
INSTALLATION .....	3
Location .....	3
Clearances .....	3
Venting .....	6
Filters .....	10
START-UP .....	10
SEQUENCE OF OPERATION .....	12
MAINTENANCE .....	12
WIRING DIAGRAMS .....	14

Manufactured By  
**Allied Air Enterprises, Inc.**  
*A Lennox International, Inc. Company*  
 215 Metropolitan Drive  
 West Columbia, SC 29170



(P) 506793-01

#### **CAUTION**

The installation of the furnace, wiring, warm air ducts, venting, etc. must conform to the requirements of the National Fire Protection Association Standard for the Installation of Oil Burning Equipment, NFPA No. 31; the National Electrical Code, ANSI/NFPA No. 70 (in the USA); the Installation Code for Oil Burning Equipment, CSA Standard CAN/CSA B139 (in Canada); the Canadian Electrical Code Part 1, CSA 22.1; the Recommendations of the National Environmental Systems Contractors Association; and any state or provincial laws or local ordinances. Local authorities having jurisdiction should be consulted before installation is made. Such applicable regulations or requirements take precedence over the general instructions in this manual.

**OIL FURNACE START-UP CHECKLIST**  
(Complete this page and keep for future reference)

Customer Name \_\_\_\_\_  
 Address \_\_\_\_\_  
 City \_\_\_\_\_ State \_\_\_\_\_ Zip Code \_\_\_\_\_  
 Furnace Model # \_\_\_\_\_ Serial # \_\_\_\_\_  
 Input Rate \_\_\_\_\_ Nozzle Used \_\_\_\_\_  
 New Construction \_\_\_\_\_ Replacement \_\_\_\_\_  
 Date of Installation \_\_\_\_\_

Installation Data

**Furnace Location:**

- A. Basement – Open \_\_\_\_\_ Enclosed\* \_\_\_\_\_  
 B. Utility room – Open \_\_\_\_\_ Enclosed\* \_\_\_\_\_  
 C. Closet – Open \_\_\_\_\_ Enclosed\* \_\_\_\_\_  
 D. Crawl space – Open \_\_\_\_\_ Enclosed\* \_\_\_\_\_

\* Provisions must be made for adequate air for combustion.  
 See **Combustion and Ventilation Air** on page 7.

**Chimney Data:**

- A. Inside \_\_\_\_\_ Outside \_\_\_\_\_  
 B. Brick or Masonry \_\_\_\_\_  
 C. Lined \_\_\_\_\_ Size: \_\_\_\_\_  
 D. Type: Class A all-purpose \_\_\_\_\_ Type L \_\_\_\_\_  
 E. Condition \_\_\_\_\_

**Flue Pipe:**

- A. Distance to chimney \_\_\_\_\_ Pitch \_\_\_\_\_  
 B. Diameter \_\_\_\_\_  
 C. Barometric damper installed \_\_\_\_\_  
 D. Drill 5/16" hole in flue pipe 12" upstream of barometric damper \_\_\_\_\_  
 E. Obtain drafting reading; adjust barometric \_\_\_\_\_

**Oil Tank Data:**

- A. Installed in basement \_\_\_\_\_  
 B. Outside \_\_\_\_\_  
 C. Buried/Depth: \_\_\_\_\_  
 D. Size: \_\_\_\_\_ gallons  
 E. Age: \_\_\_\_\_  
 F. Date of last cleaning: \_\_\_\_\_

**Oil Lines:**

- A. Size: 3/8" \_\_\_\_\_ 1/2" \_\_\_\_\_ Other \_\_\_\_\_  
 B. Single pipe \_\_\_\_\_ Two pipe \_\_\_\_\_  
 C. Distance from tank \_\_\_\_\_ Lift \_\_\_\_\_  
 D. Filter type \_\_\_\_\_ Inspect \_\_\_\_\_ Change \_\_\_\_\_  
 E. Pressure test \_\_\_\_\_  
 F. Recheck all fittings for tightness \_\_\_\_\_

**Thermostat**

- A. Type: Heating \_\_\_\_\_ Cooling \_\_\_\_\_  
 B. Anticipator set \_\_\_\_\_  
 C. Wires: New \_\_\_\_\_ Old \_\_\_\_\_

**Air Filter**

- A. Type: Permanent \_\_\_\_\_ Disposable \_\_\_\_\_  
 B. Installed \_\_\_\_\_  
 C. Size: \_\_\_\_\_

Start-Up Procedure

- A. Close disconnect switch \_\_\_\_\_  
 B. Set thermostat to call for heat \_\_\_\_\_  
 C. Bleed air from lines and pump; run for 20 seconds after bubble disappears \_\_\_\_\_  
 D. Install vacuum gauge; check pump vacuum \_\_\_\_\_  
 E. Install pressure gauge; adjust pressure to 140 psig (except on 57 models – adjust to 100 psig) \_\_\_\_\_  
 Always verify proper pump pressure to corresponding tables with instructions supplied with unit.  
 F. After 10 minutes of operation, obtain flue temperature reading: 1<sup>st</sup> \_\_\_\_\_ 2<sup>nd</sup> \_\_\_\_\_ 3<sup>rd</sup> \_\_\_\_\_  
 G. Obtain smoke reading: 1<sup>st</sup> \_\_\_\_\_ 2<sup>nd</sup> \_\_\_\_\_ 3<sup>rd</sup> \_\_\_\_\_  
 H. Measure CO<sub>2</sub>: 1<sup>st</sup> \_\_\_\_\_ 2<sup>nd</sup> \_\_\_\_\_ 3<sup>rd</sup> \_\_\_\_\_  
 I. Check draft overfire \_\_\_\_\_ Breech \_\_\_\_\_  
 J. Air shutter setting \_\_\_\_\_ Locked \_\_\_\_\_  
 K. Measure static pressure in duct system  
     Static pressure on supply side \_\_\_\_\_  
     Static pressure on return side \_\_\_\_\_  
     Static pressure drop \_\_\_\_\_  
 L. Temperature rise after steady state conditions have been achieved: Supply side \_\_\_\_\_ Return side \_\_\_\_\_  
 M. Block off return air (limit control checkout); burner should shut down in 2 or 3 minutes \_\_\_\_\_

Owner Record

Installed By: \_\_\_\_\_  
 Dealer \_\_\_\_\_  
 Address \_\_\_\_\_  
 \_\_\_\_\_  
 Telephone # \_\_\_\_\_  
 License # \_\_\_\_\_

Manufactured By  
**Allied Air Enterprises, Inc.**  
**A Lennox International, Inc. Company**  
 215 Metropolitan Drive  
 West Columbia, SC 29170

**These checks or tests are required for all oil units.**

## INSTALLATION

Read all instructions before starting work so installation will conform to Underwriter's Laboratories or Canadian Standards Association requirements. The furnace must be level when placed on its foundation (upflow, counterflow, and basement models) or in its suspended position (horizontal models). Using a carpenter's level, check the furnace in at least two directions. The weight must be distributed evenly before the duct work is attached.

***These instructions must be placed on or near the furnace in a conspicuous place.***

### Inspection of Shipment

***This furnace is shipped in one package, completely assembled and wired.*** The thermostat is shipped in a separate carton when ordered.

Upon receipt of equipment, carefully inspect it for possible shipping damage. If damage is found, it should be noted on the carrier's freight bill. Damage claims should be filed with the carrier immediately. Claims of shortages should be filed with the seller within 5 days.

### Location

Locate the furnace as centrally as possible so that all warm pipes to the various rooms are nearly the same length. This allows each room to receive an equal and proper amount of heat. This may vary with each particular installation. Position the furnace so the pipe connection to the chimney will be of minimum distance and have a minimum of fittings.

In utility rooms or similar installations, the door or access opening should be large enough to permit replacement of the furnace, or another appliance such as a water heater, without disturbing any other equipment.

***LHR 196 rear flue models are approved for horizontal applications only.***

For attic installations, a booster oil pump may be required to supply oil to the oil burner. Check state and local codes for specific requirements.

### **!WARNING**

In any installation where damage from oil may occur, a drain pan must be installed. The drain pan must be large enough size to completely prevent any potential oil damage. The drain pan piping must be sized to drain the oil pump capacity and the piping must be routed to drain the oil back to the oil tank.

### Clearances

A minimum of 24" is recommended in front of the furnace for servicing the burner on all models.

See Table 2 on page 4 for a complete listing of the minimum clearances required for basement type and upflow installations. See Figure 2 on page 5 for the minimum clearances required for horizontal installations and Figure 3 on page 5 for the minimum clearances required for counterflow installations. **When accessibility clearances are greater than fire protection clearances, the accessibility clearances take precedence.**

**Minimum Clearances to Combustibles - Upflow Installations**

	Basement Type Units			Hi-Boy (Upflow)	
	LBF. LBR.			LUF	
	57/72 - 84/95	112/125	140/168 - 168/196	57/72 - 84/95	112/125
Top of Plenum and Duct Work	2"	2"	2"	2"	2"
Plenum Sides	3"	3"	3"	3"	3"
Furnace Sides	6"	6"	6"	0"	0"
Furnace Rear	24"	24"	24"	0"	0"
From Front Door	4"	4"	4"	4"	4"
Flue Pipe Clearance to Combustibles**	9"	9"	9"	6"	6"
Type of Floor	Comb.	Comb.	Comb.	Comb.	Comb.
Combustion Air Openings (2 req'd)	10"x20"	11"x22"	11"x22"	10"x20"	11"x22"

\* A passage, suitable for a large person, shall be provided between the furnace and chimney for inspection or replacement of the flue connector when necessary. A clearance of 24" shall be allowed at the rear and on one side of the furnace for service and cleaning of the blower.

\*\* The minimum clearance shown to the flue pipe may be reduced by using special protection permitted by local building codes and National Fire Protection Association Standards and CSA 139.

**Table 1**

### Non-Suspended Horizontal Installation

To support the furnace from below, set the furnace on non-combustible material suitable to support the weight of the unit. Using a carpenter's level, check furnace in at least two directions. To make adjustments, use shims of non-combustible material. Seven inches minimum clearance between the bottom of the flue pipe and combustible material is required. Installation on a combustible floor requires a 1" clearance from the floor for units with a front flue and a 4" clearance from the floor for units with a rear flue.

### Suspended Horizontal Installation

Before suspending the furnace, remove the knockouts in the top of the panel at the warm air discharge and at the blower panel. Use 3/8" threaded rods cut to the desired length. Use one flat washer and two nuts on each rod (see Figure 1). Place one nut and one flat washer on the inside of the unit and one nut on the outside. The outside nut serves as the locking nut. Level the unit using the inside nuts.

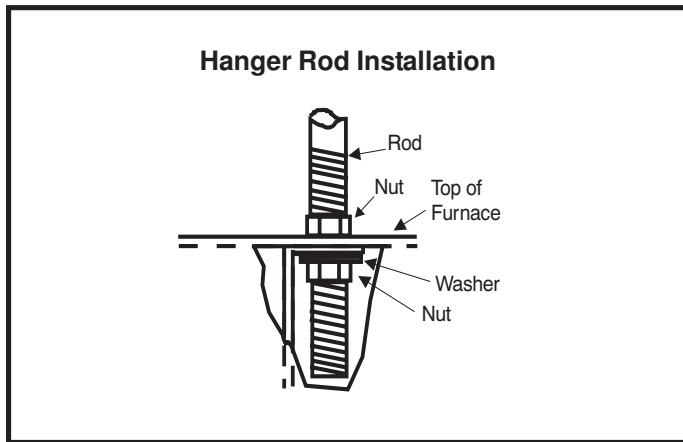

Figure 1

### Horizontal Installation Reversing the Air Flow

This furnace is assembled to discharge warm air out the left side (when viewed facing the burner side of the furnace). If installation requires that the flow be reversed, follow these steps:

1. Rotate the furnace 180° so that the warm air is discharged out the right side.
2. Remove the oil burner and the screws securing the burner mounting plate. Rotate the burner mounting plate 180° and reattach with screws. Remount the burner in the upright position.
3. Remove the screws holding the limit control in place. Relocate the limit control to the top side of the front panel using the knockout hole provided.

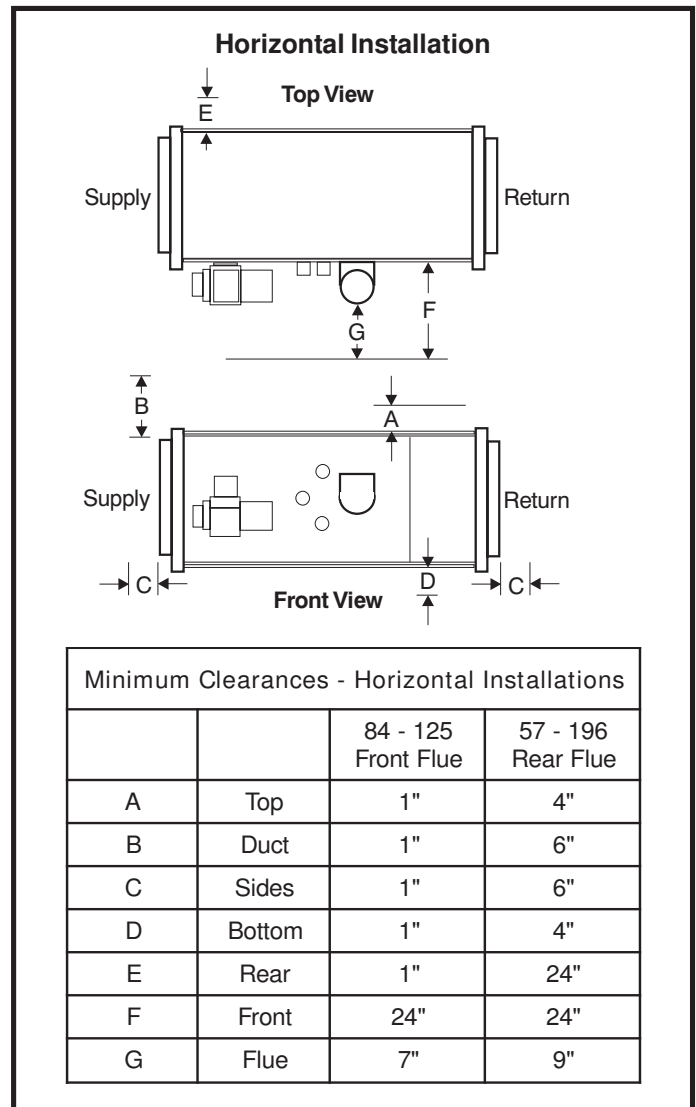

Figure 2

### Counterflow Installation

This furnace is assembled to discharge warm air out the left side (when viewed facing the burner side of the furnace). To convert to counterflow:

1. Rotate the furnace so the return is on top and the supply is on bottom.
2. Remove the oil burner and the screws securing the burner mounting plate. Rotate the burner mounting plate 90° clockwise and reattach the screws into the heat exchanger. Remount the burner.
3. Refer to Figure 3 for minimum clearances required.

**When installing a counterflow unit on combustible flooring, a combustible floor base must be used.** See Figure 4 on page 6 for more information on using a combustible floor base kit.

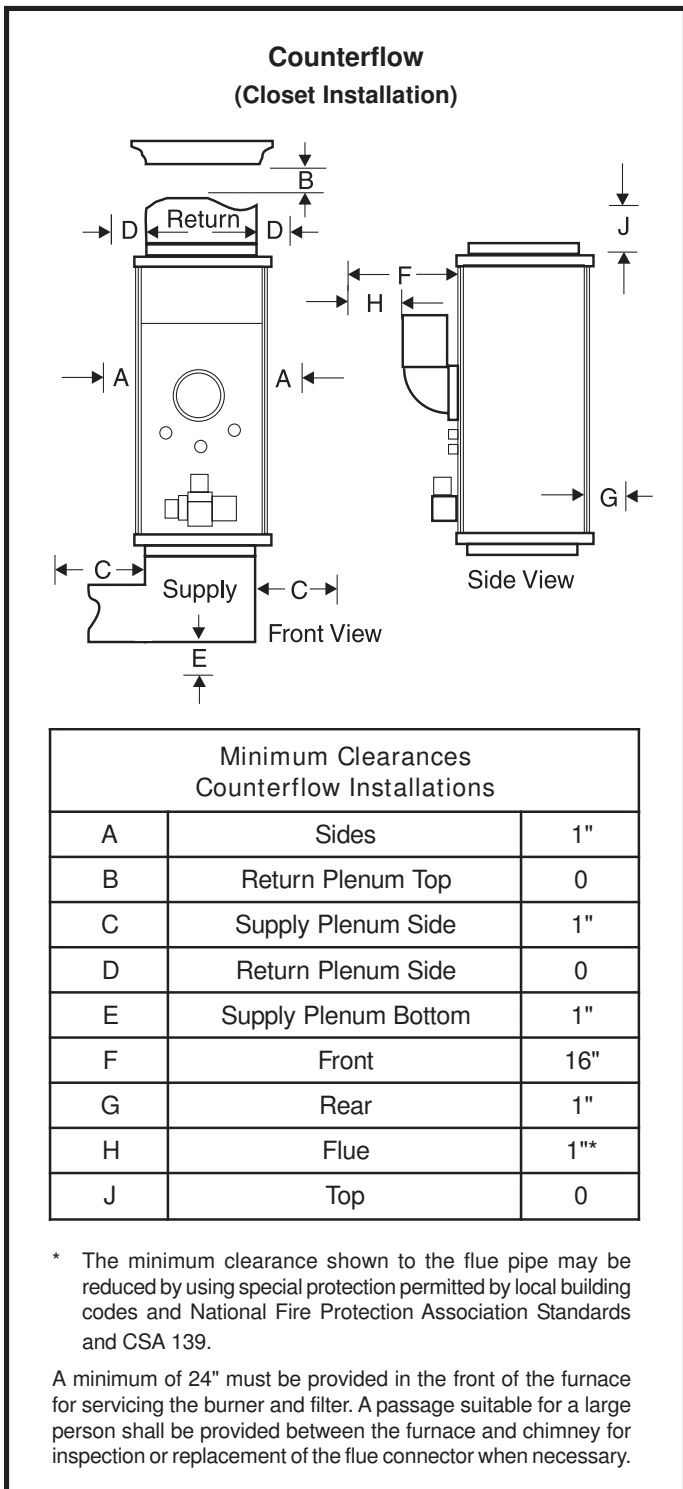

**Figure 3**

Kits are also available for counterflow applications where a vestibule cover is needed for safety reasons.

Vestibule cover kits:

Kit for 57/72 & 84/95 counterflow models – AVEST547-1

Kit for 112/125 counterflow models – AVEST548-1

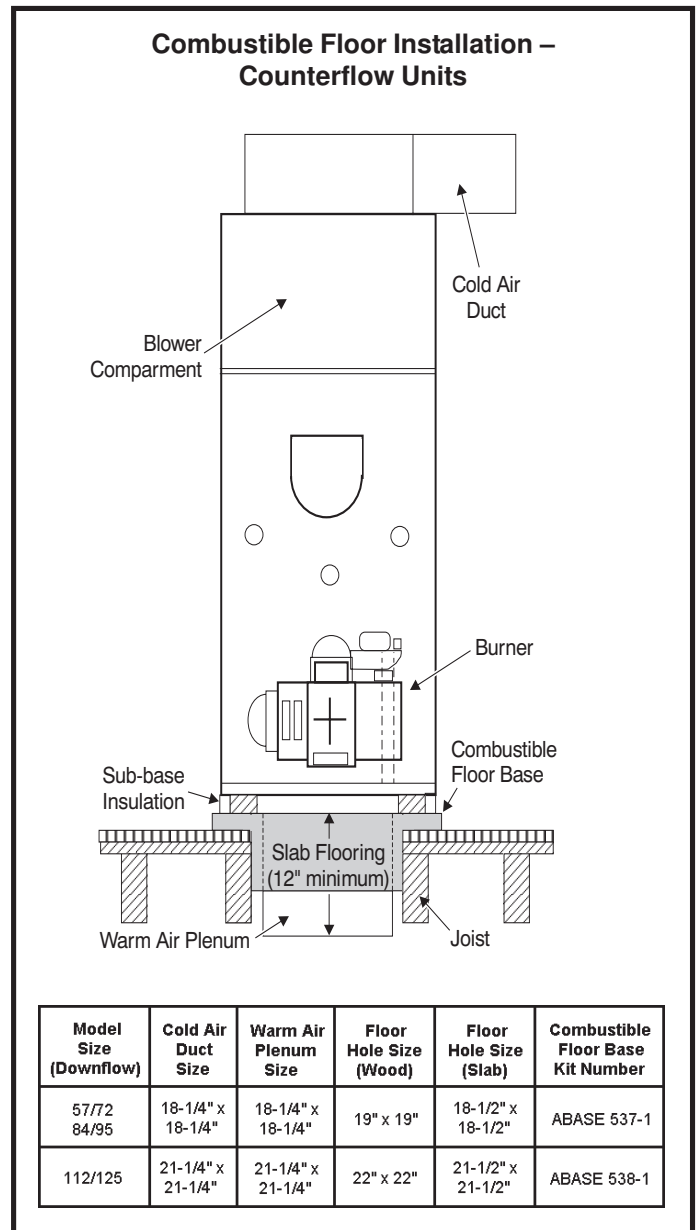

**Figure 4**

It is very important that the furnace be exactly level since a level unit is necessary for proper fitting of parts. Using a carpenter's level, check the furnace in at least two directions. If the furnace is not level, place fireproof wedges or shims between the low side of the furnace and the floor and check again with the level. The weight of the unit must be distributed evenly on all four corners.

#### Air Conditioning

### ⚠ WARNING

When an air conditioning unit is used in conjunction with the furnace, the evaporator coil must be installed in the discharge (supply) air. Do not install an evaporator coil in the return air; excessive condensation will occur within the furnace.

## Combustion and Ventilation Air

Adequate provisions for combustion air, ventilation of furnace, and dilution of the gases must be made. When a furnace is installed in an unconfined space in a building, it can be assumed that infiltration will be sufficient to supply the required air.

If the furnace is installed in a confined space and combustion air is taken from the heated space, the supply air and ventilating air must be through two permanent openings of equal area. A confined space is "a space whose volume is less than 50 cubic feet per 1000 btu per hour of the combined input rating of all appliances installed in that space." One opening must be within 12" of the ceiling and the other within 12" of the floor. Each opening must have a minimum free area of at least 1 square inch per 1000 btu per hour of total input rating of all appliances with the space but not less than 100 square inches.

If the furnace is installed in a space within a building of tight construction, air must be supplied from outdoors. In this case, one opening shall be within 12" of the ceiling and the other within 12" of the floor. If vertical combustion ducts are run, each opening must have a free area of at least 1 square inch per 4000 btu per hour. If horizontal combustion ducts are run, 1 square inch per 2000 btu per hour of the total input of all appliances is required.

The furnace is designed to use air inside the dwelling for combustion. If additional combustion air is required, installing fresh air kit ABOOT571 allows air from outside the dwelling to be brought in to the oil burner. This kit brings air into the burner through air inlet ductwork run through the furnace cabinet side panel and terminated outside the dwelling (see Figure 5). The kit includes a vacuum relief valve to guard against combustion problems associated with directly connecting oil burners to the outside.

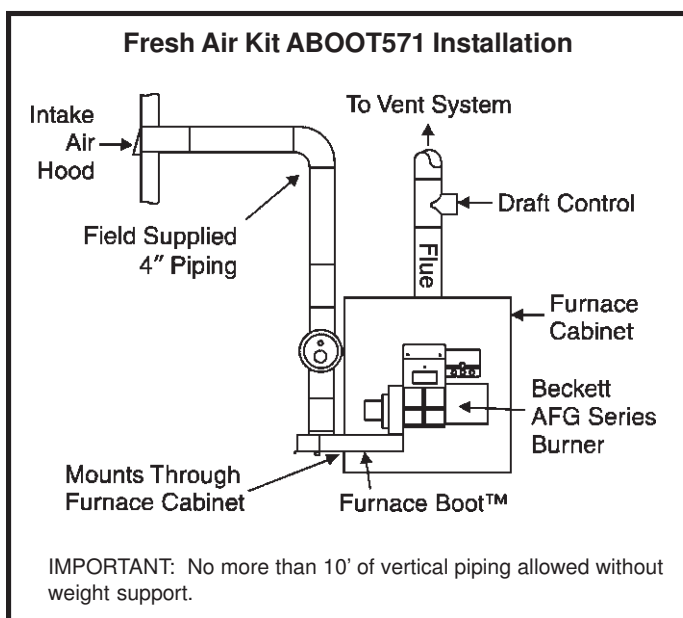

Figure 5

### **⚠ WARNING**

Combustion air openings in the front of the furnace must be kept free of obstructions. Any obstruction will cause improper burner operation and may result in a fire hazard or injury.

### **⚠ WARNING**

The barometric control shall be in the same atmospheric pressure zone as the combustion air inlet to the furnace. Deviation from this practice will cause improper burner operation and may result in a fire hazard or injury.

A return air duct system is recommended. Where there is no complete return air duct system, a return connection should be run full size to a location outside the confined space and completely sealed so that no air from the confined space can be circulated through the heating duct system.

### **Outdoor Make Up Air**

A minimum mixed return air temperature of 60 - 65°F must be maintained for outdoor make up air to prevent condensation and corrosion.

### **Venting Chimney**

Before installing the furnace, a thorough inspection of the chimney should be made to determine whether repairs are necessary and that the chimney is of the proper size and constructed in accordance with the requirements of the National Board of Fire Underwriters or Canadian Standards Association. The smallest dimension of the chimney should be at least equal to the diameter of the flue pipe of the furnace. Be sure the chimney will produce a steady draft sufficient to remove all the products of combustion from the furnace. A fabricated vent system the same size as the flue outlet of the furnace may also be used. If a manufactured vent is used, it must be listed for use with oil-fired equipment.

### **⚠ WARNING**

This furnace is certified for use with Type "L" vent, Type "A", and "factory-built" chimneys. "B" vent must not be used with oil furnaces.

1. Local building codes may have more stringent installation requirements and should be consulted before installation of the unit.



2. The flue pipe should be as short as possible to do the job.
3. The internal diameter of the flue pipe or vent connector shall equal the outlet diameter of the flue opening of the appliance. If the flue vent collar is larger or smaller than the flue pipe, a gradual transition piece shall be used and the system shall be tested to ensure that adequate draft is provided.
4. Single wall flue pipe should not run outside or through any unconditioned space.
5. Chimney flue shall extend at least 3' above the highest point at which the chimney comes in contact with the roof and not less than 2' above the highest roof surface or structure within 10' of the chimney on a horizontal plane perpendicular to the chimney. Not more than 4" of chimney flue above the chimney cap shall be considered in computing this height.
6. The flue pipe must not pass through a floor or ceiling. Clearances to single wall flue pipe should be no less than specified in the Clearances section beginning on page 3.
7. The flue pipe may pass through a wall where provisions have been made for a thimble as specified in the Standards of the National Board of Fire Underwriters (see Figure 6).

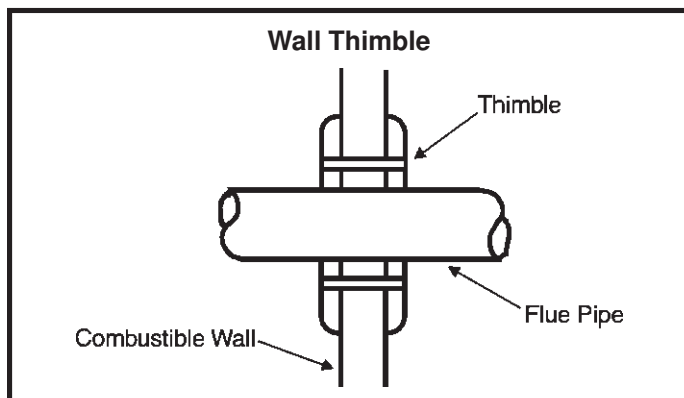

Figure 6

8. The flue pipe should slope upward toward the chimney on a horizontal run of at least 1/4" per foot and should be supported by something other than the furnace (see Figure 7 on this page and Figure 8 on page 8).
9. Extend the flue pipe into the chimney so that it is flush with the inside of the flue liner. Seal the joint between the pipe and the liner.
10. The furnace shall be connected to a factory-built chimney or vent complying with a recognized standard, or a masonry or concrete chimney lined with a lining material acceptable to the authority having jurisdiction.

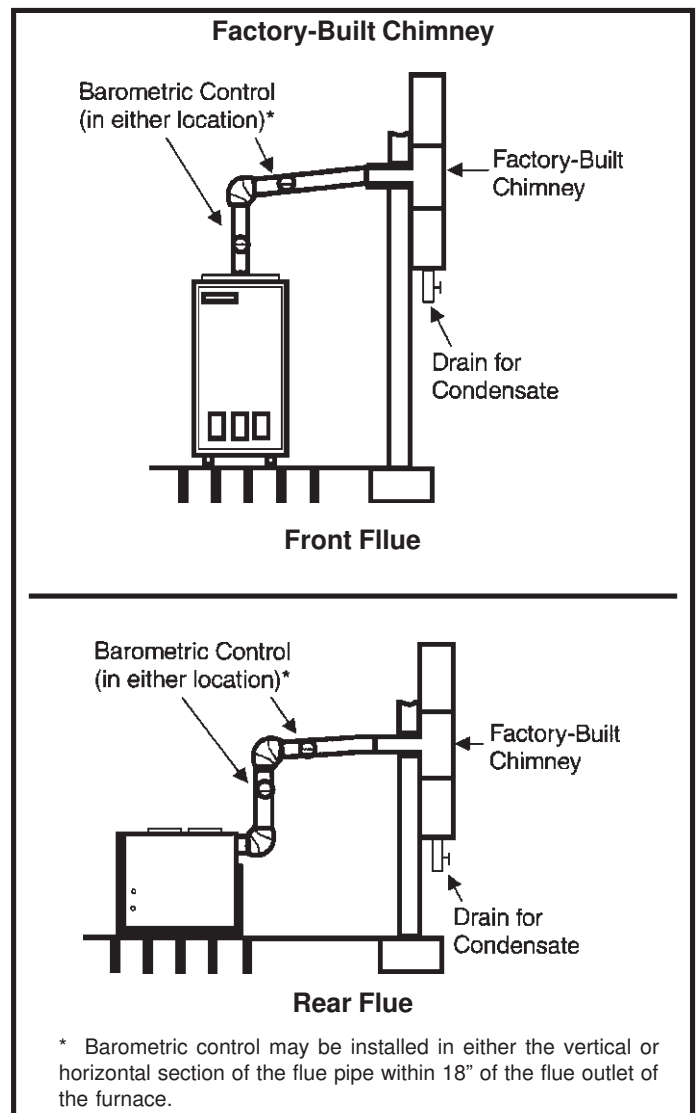
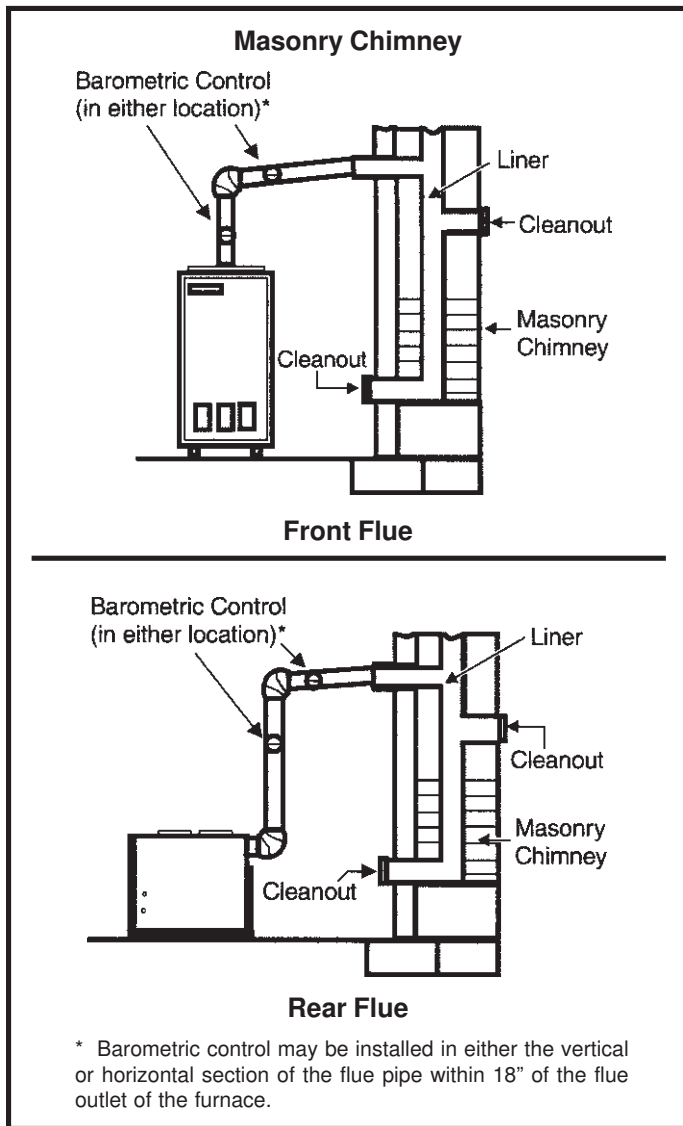

Figure 7

11. When two or more appliances vent into a common flue, the area of the common flue should not be less than the area of the largest flue or vent connection plus 50% of the areas of the additional vents or flue connections. The chimney must be able to sufficiently vent all appliances operating at the same time.
12. **The flue pipe shall not be connected to a chimney flue serving a solid fuel appliance or any mechanical draft system.**
13. All unused chimney openings should be closed.
14. All vent pipe run through unconditioned areas or outside shall be constructed of factory-built chimney sections (see Figure 7).
15. Where condensation of flue gases is apparent, the vent shall be constructed to prevent the condensation from entering the flue transition box opening. Provisions shall be made to drain off the condensate (see Figure 7).



**Figure 8**

16. Vent connectors serving this appliance shall not be connected into any portion of a mechanical draft system operating under positive pressure.

17. Keep the area around the vent terminal free of snow, ice, and debris.

**Horizontal Venting**

The design of this furnace has been approved for horizontal venting with the following mechanical vent systems:

- Tjernlund (sideshot) - Models SS1, SSC, SS2\*
- Field Control - Model SWG-5S with CK63 Control Kit

Vent systems are available through the local distributor. Refer to the manufacturer's installation instructions for proper installation procedures and service parts information.

\* SS2 Vent System is not approved for 196 oil furnaces

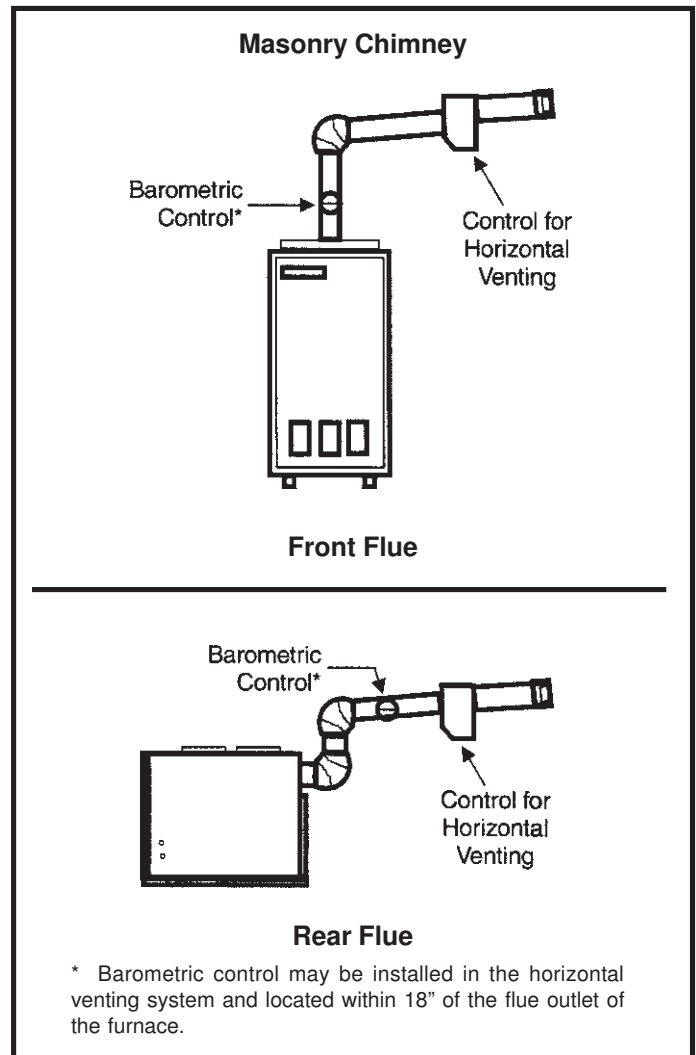

**Figure 9**

Barometric draft control must be used in the horizontal venting (sidewall) system. It must be located within 18" of the furnace flue outlet (see Figure 9).

Do not common vent with any other appliance when using the sidewall system.

Maximum permissible vent length is 100 equivalent feet, and minimum permissible length is 15 equivalent feet. Calculate the equivalent vent pipe footage from the furnace to the mechanical vent system by adding the straight vent pipe length and equivalent elbow lengths together. Each 90° elbow is equivalent to 10' of straight pipe; each 45° elbow is equal to 5' of straight pipe.

**Removal of Unit from Common Venting System**

When an existing furnace is removed from a common venting system service other appliances, the venting system is likely to be too large to properly vent the remaining attached appliances. The following test should be conducted with each appliance while the other appliances connected to the common venting system are not in operation.



1. Seal any unused openings in the common venting system.
2. Visually inspect the venting system for proper size and horizontal pitch and determine there is no blockage or restriction, leakage, corrosion, or other deficiencies which could cause an unsafe condition.
3. Insofar as is practical, close all building doors and windows between the space in which the appliances remaining connected to the common venting system are located and other spaces in the building. Turn on clothes dryers and any appliance not connected to the common venting system. Turn on exhaust fans, such as range hoods and bathroom exhausts, so they will operate at maximum speed. Do not operate a summer exhaust fan. Close fireplace dampers.
4. Following the lighting instructions, place the unit being inspected in operation. Adjust the thermostat so the appliance will operate continuously.
5. Test for spillage at the draft control relief opening after 5 minutes of main burner operation. Use the flame of a match or candle.
6. After it has been determined that each appliance remaining connected to the common venting system properly vents when tested as outlined above, return doors, windows, exhaust fans, fireplace dampers, and any other fuel burning appliance to their previous condition of use.
7. If improper venting is observed during any of the above tests, the common venting system must be corrected. **See National Fuel Gas Code, ANSI Z223.1 (latest edition) or CAN/CGA B149.1 & .2 Installation Codes to correct improper operation of common venting system.**

#### **Smoke Pipe and Draft Control**

Connect the furnace vent to the chimney with galvanized smoke pipe and fittings, maintaining full diameter of furnace vent throughout. No reduction in diameter of pipe is allowed. It is best to have smoke pipe as short and direct as possible. The smoke pipe shall maintain a rise of at least 1/4" per foot. Install draft control at least 12" beyond the furnace. If there is no space to install the draft control in the smoke pipe, it may be installed in the chimney above the smoke pipe (see Figure 10).

#### **Supply and Return Air Plenum**

Secure return air plenum to unit using sheet metal screws.

Follow these procedures when installing supply air plenum:

1. Use sealing strips of fiberglass.

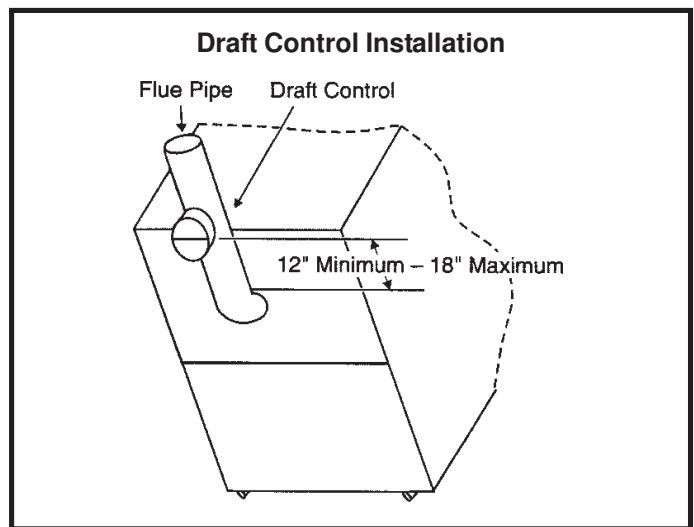

**Figure 10**

2. Attach the plenum to the furnace or evaporator cabinet with sheet metal screws.
3. Both supply and return air plenums shall be square and at least 18" long. They should be the same dimension as the furnace opening.
4. Install supply and return air ducts as desired.

#### **Oil Supply and Oil Filter Connection**

Continuous lengths of heavy wall copper tubing or steel pipe are recommended and should be installed under the floor or near walls to protect from damage. Do not run lines on floor joists or other reverberating surfaces. Always use flare fittings located in accessible places.

Install a generous capacity oil filter inside building between the fuel shutoff valve and burner. Locate filter and valve close to burner for easy servicing. **An oil filter is required for all models.** A 100-micron filter is recommended.

#### **Combustion Chamber**

The combustion chamber is installed in the furnace at the factory. Read the instruction plate on the front of the unit concerning proper care of the chamber.

This combustion chamber is made of preformed ceramic fiber material. Use extreme care when installing the oil burner so that the chamber is not damaged around the burner tube.

## Fan and Limit Control

The fan and limit control is installed and wired at the factory. Replacement of the fan and limit control must be made with an identical control as originally supplied on the equipment from the factory including “fan” and “limit” stops. The use of any other controls will void the warranty of the furnace. Operation of this furnace with greater than 130°F “Fan On” air temperature will also void the warranty of the furnace.

## Electrical Wiring

All wiring must conform to the National Electrical Code, the Canadian Electrical Code, and any local codes. Connect the 115-volt, single phase service to the unit at the junction box. Use a separate fused branch electrical circuit containing a properly sized fuse or circuit breaker. Run this circuit directly from the main switch box to an electrical disconnect that is readily accessible and located near the furnace. Follow carefully the wiring diagrams adhered to the inside of the blower compartment door.

The electrical supply to the mechanical vent system must be supplied from the appliance. All wiring must be appropriate Class I wiring. Wiring must be installed in rigid metal conduit, intermediate metal, or be otherwise suitably protected from physical damage. Refer to the wiring diagrams supplied with the venter kit for proper electrical connections.

## Thermostat

Locate the thermostat on an inside wall in a room usually occupied during the day, such as a living room or dining room, at a height of 4-1/2” from the floor. Avoid direct sunlight or supply air from a register. Make sure the location is not adjacent to appliances such as ovens or lights. Wire the thermostat with minimum of #18 AWG thermostat wire.

## Humidifier

A humidifier can be installed with this furnace. Refer to the humidifier manufacturer’s instructions for specific connection information (see also Figure 12 on page 13).

## Electronic Air Cleaner

An electronic air cleaner can be installed with this furnace. Refer to the electronic air cleaner manufacturer’s instructions for specific connection information (see also Figure 13 on page 13).

## Filters

### *Horizontal/Counterflow*

Neither the horizontal nor the counterflow units contain filters. Filters must be installed in the return duct system. Optional filter kits are available. Contact the supplier to obtain the correct filter kit.

Optional filter kits:

Kit for 57/72 & 84/95 units - #AFILT535-1

Kit for 112/125 Units - #AFILT536-1

Kit for 196 units - #AFILT561-1

## **Upflow/Basement**

Permanent filters are supplied with these units. The large upflow unit comes with two filters. Use both filters when more than 1600 CFM is needed. To clean the filters, shake to remove any excess dirt and/or use a vacuum cleaner. Wash with soapy detergent water and dry. Metal permanent filters need to be oiled after washing to increase their effectiveness. The filters should be cleaned at least once a month, or more frequently in unusually dusty environments.

***Never leave the access panels to the blower compartment off or partially open.***

## START-UP

### Oil Burner

#### ***Burner Specification: Factory Settings***

1. Burner type: AFG (57 - 196)
2. Air Tube Combination:  
AF46XZTHS (57/72)  
AF46XNHS (84/95 AND 112/125)  
AF55YB (140/168)  
AF56WF (196)
3. AFG Static Plate 3-3/8”

### **⚠ WARNING**

Do Not attempt to start the burner when excess oil has accumulated in the chamber, when the furnace is full of vapor, or when the combustion chamber is very hot. Such actions could result in property damage, personal injury, or death.

### **⚠ CAUTION**

Do Not start burner unless blower access door is secured in place.

### Burner Start-Up

1. Set the operating control to call for heat.
2. Open all shutoff valves in the oil supply line to burner.
3. Close the line switch to the burner. If the burner does not start immediately, check the manual overload switch on the motor (if applicable), and the safety switch of the furnace primary control.
4. While the ignition is on, press and release the reset button (hold 1/2 second or less). If the control has not locked out since its most recent complete heat cycle, the lockout time will be extended to 4 minutes, and the ignition will remain on for the entire heat cycle.
5. Bleed the pump until all froth and bubbles are purged. The bleed port is located on the bottom of the fuel pump. To bleed, attach a clear plastic hose over the vent plug. Loosen the plug and catch the oil in an empty container. Tighten the plug when all the air is purged. **NOTE:** Bleeding might not be necessary with a two-pipe system.
6. If prime is not established within the extended lockout time, the control will lock out. Press the reset button to reset the control (see Step 4). **NOTE:** the reset button can be held for 15 seconds for the Beckett 7505B primary control, at any time to reset the control's lockout counter to zero and send the control to standby.
7. Repeat Steps 4 and 5, if needed, until pump is fully primed and oil is free of bubbles. Then terminate the call for heat, and the control will resume normal operation.

### Burner Adjustment

**All adjustment to this furnace and its components must be done by a qualified service technician.**

Refer to Table 2 for nozzle and pump pressure information.

Furnace Model	Burner Head	Nozzle/Angle	Spray Pattern	Pump Pressure
57*	F0	.50 GPH/80°	Delavan A	100 PSI
72*	F0	.65 GPH/80°	Delavan B	100 PSI
84*	F3	.65 GPH/80°	Delavan B	140 PSI
95*	F3	.75 GPH/80°	Delavan B	140 PSI
112	F4	.85 GPH/80°	Delavan B	140 PSI
125	F4	1.00 GPH/80°	Delavan B	140 PSI
140	F6	1.10 GPH/80°	Delavan B	140 PSI
168	F6	1.25 GPH/80°	Delavan B	140 PSI
196	F16	1.50 GPH/80°	Delavan B	140 PSI

\* Denotes low fire baffle installed. See oil burner specifications included with instructions.

**Table 2**

The proper way to adjust an oil burner is with a CO<sub>2</sub> analyzer and a smoke gun. A properly adjusted burner will result in a quiet, clean fire which will prevent sooting and frequent cleaning. To establish tolerance or a "window of operation" into the unit, do not exceed #1 smoke. This will give the burner more flexibility when there are changes in the surrounding environment.

To adjust the burner:

1. Punch a 5/16" diameter service hole in the flue outlet. This sampling hole should be at least two flue diameters above the breeching, or elbow at the breeching, but ahead of the barometric damper.
2. Operate burner, adjust air setting for good flame by visual observation, and run for at least 10 minutes or until operation has stabilized. A good flame will be entirely contained in the combustion chamber and will be predominantly yellow-white in color. As flame quality lessens, the flame will turn more orange in color and will start to rise above the combustion chamber.
3. Take a draft reading at the service hole. Adjust barometric draft control in the stack to achieve and overfire draft of  $-.01"$  to  $-.02"$  and a breach of  $-.02"$  to  $-.04"$ .
4. Pull and record a smoke reading at the service hole using an industry standard smoke tester. If smoke is evident, it could be caused by a poor nozzle or combustion setting. In some cases, it may be caused by difference in oil or an unusual condition of installation.
5. If the burner is producing more than #1 smoke, loosen the air control adjustment screw and rotate the band until the flame appears clean.
6. Reset the draft if the combustion head or air settings were adjusted (see Step 3).
7. Using a suitable test instrument for CO<sub>2</sub>, take and record a CO<sub>2</sub> reading at the service hole. The CO<sub>2</sub> measured in the stack should be a minimum of 11% CO<sub>2</sub>.
8. Using a suitable thermometer, obtain and record the flue gas temperature at the service hole.
9. Use the CO<sub>2</sub> reading and the flue gas temperature reading to determine unit efficiency.
10. When the proper combustion and smoke readings have been achieved, tighten the air adjustment screw.
11. Recheck the draft, smoke, combustion, and flue gas temperature.

## MAINTENANCE AND SERVICE

### Beckett Oil Burner Nozzle Adjustment

Burner must be removed from furnace for this procedure.

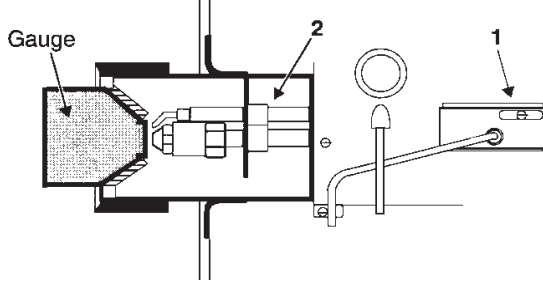

To adjust nozzle:

1. Loosen screw.
2. Slide entire nozzle/electrode assembly back and forth until nozzle just touches gauge

Figure 11

### Nozzle and Electrode Alignment

Proper nozzle and electrode depth and alignment are essential for proper burner operation. Figure 11 shows the proper adjustment procedure using the Beckett "T" gauge.

To check and adjust the nozzle depth:

1. Insert the small end of the "T" gauge into the end of the cone and measure from the flat of the end cone to the tip of the nozzle. The proper measurement should be 1.13". When the depth is correct, the tip of the nozzle should just touch the base of the "T" gauge.
2. Nozzle adjustments are made by sliding the entire nozzle assembly forward or backward within the blast tube (see Figure 11).

To check nozzle alignment:

1. Insert the small end of the "T" gauge into the end of the cone and measure the nozzle and electrode alignment against the center lines marked on the gauge.
2. If the nozzle is not centered, but found to be too far left or right, a new nozzle will need to be ordered. **Do not attempt to adjust by bending the 90° elbow in the oil line.**

### SEQUENCE OF OPERATION

1. The thermostat calls for heat, activating the burner motor and ignitor.
2. After a 15-second pre-purge period, the oil solenoid valve is energized and ignition is established.
3. After thermostat is satisfied, thermostat circuit will open.
4. Power to the burner is interrupted, thus shutting down the burner.

### Oil Burner

It is recommended that the nozzle and oil filter be checked before each heating season. Also recheck the conditions shown on the **OIL FURNACE START-UP CHECKLEST** found on page 2.

**Always keep the valve shut off if the burner is shut down for an extended period of time.**

### Flue Pipe

Have the flue pipe inspected annually by a qualified service technician. If any soot or ash has formed inside the flue pipe, remove and clean. If the flue pipe has any holes or is rusted out, replace with a new flue pipe of the same size. Inspect the flue draft control device and replace if defective.

### Blower

Blower motor is pre-lubricated and sealed for extended operation. No further lubrication is required.

The blower assembly may be removed from the cabinet for cleaning and servicing of the blower. Disconnect power to the unit before servicing.

### Heat Exchanger

To clean the heat exchanger:

1. Remove the vent pipe from the furnace.
2. Remove the locking screws and the caps from the two cleanout tubes; remove the flue access elbow.
3. Using a long spiral wire brush, sweep down the outer drum of the heat exchanger. Using a shop vacuum hose attachment, vacuum out all loose debris.
4. Remove the locking screw and cap from the inspection tube and with the spiral wire brush reach upward toward the rear of the heat exchanger to clean out the crossover tube; replace the locking screw and cap on the inspection tube.
5. Do not attempt to clean the combustion chamber, as it can be easily damaged.
6. Replace the three previously removed cleanout caps and flue access elbow, making sure to reinstall the locking screws.
7. Brush out and vacuum the vent outlet area of the outer drum and reattach the vent pipe.
8. Clean up around burner, blower deck, and vestibule area.

Heat exchanger cleanout kit #ABRSH380-3 is available from the manufacturer.

### Emergency Fuel Pump Replacement

If replacement of the A2EA6520 fuel pump becomes necessary, replace it with another Beckett CleanCut fuel pump. In an emergency situation where the correct replacement parts are not available, an A2VA7116 fuel pump could be used. This option can produce a smoky start-up and shutdown that could result in fouling of a heat exchanger.

**This is only a short-term option and should be used only until the correct parts can be obtained and installed.**

### Complete National Fuel Gas Codes are available from:

1. **American Gas Association**  
1515 Wilson Boulevard  
Arlington, VA 22209
2. **National Fire Protection Association, Inc.**  
1 Battery March Park  
Quincy, MA 02269
3. **American National Standards Institute, Inc.**  
Publications Sales Department  
11 West 42nd Street  
New York, NY 10036

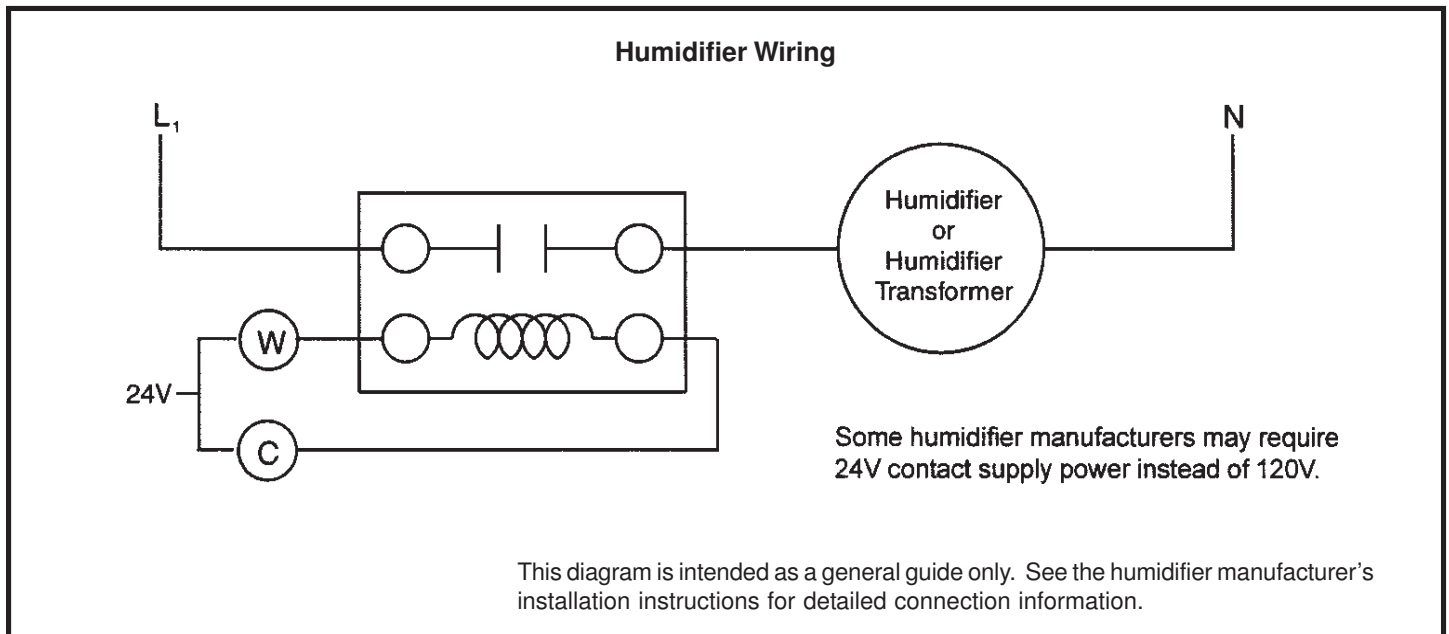

Figure 12

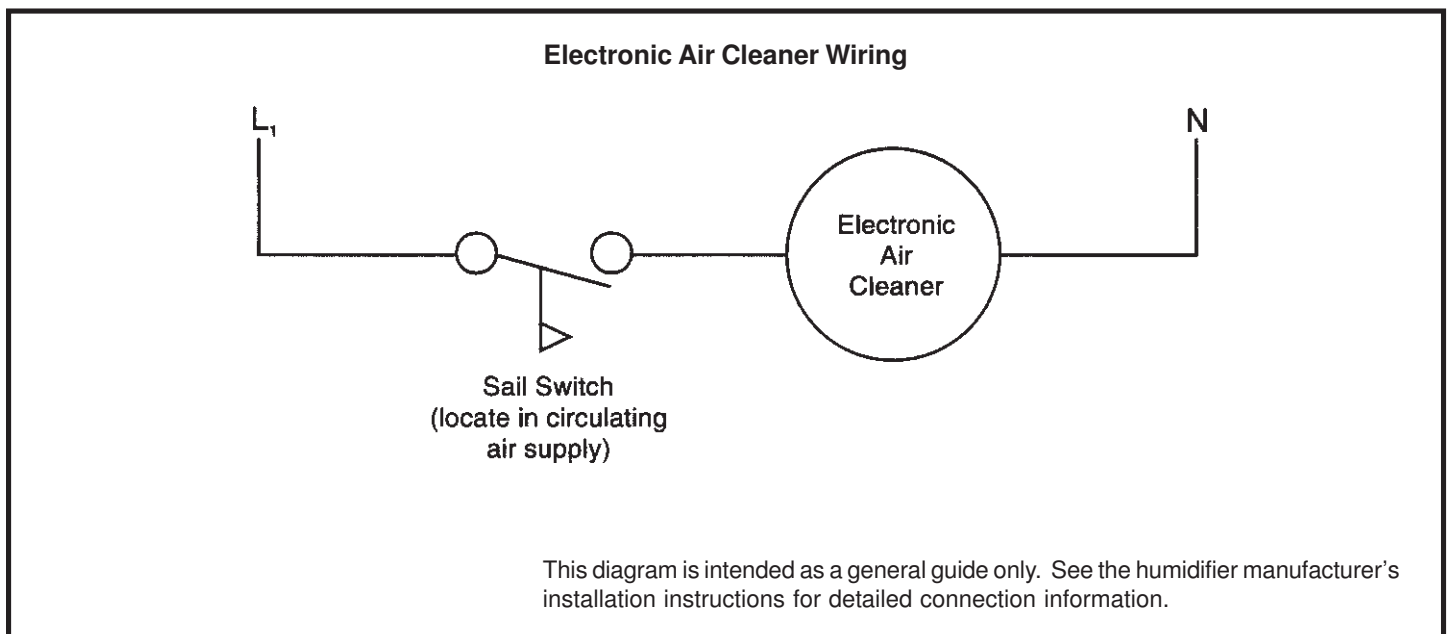
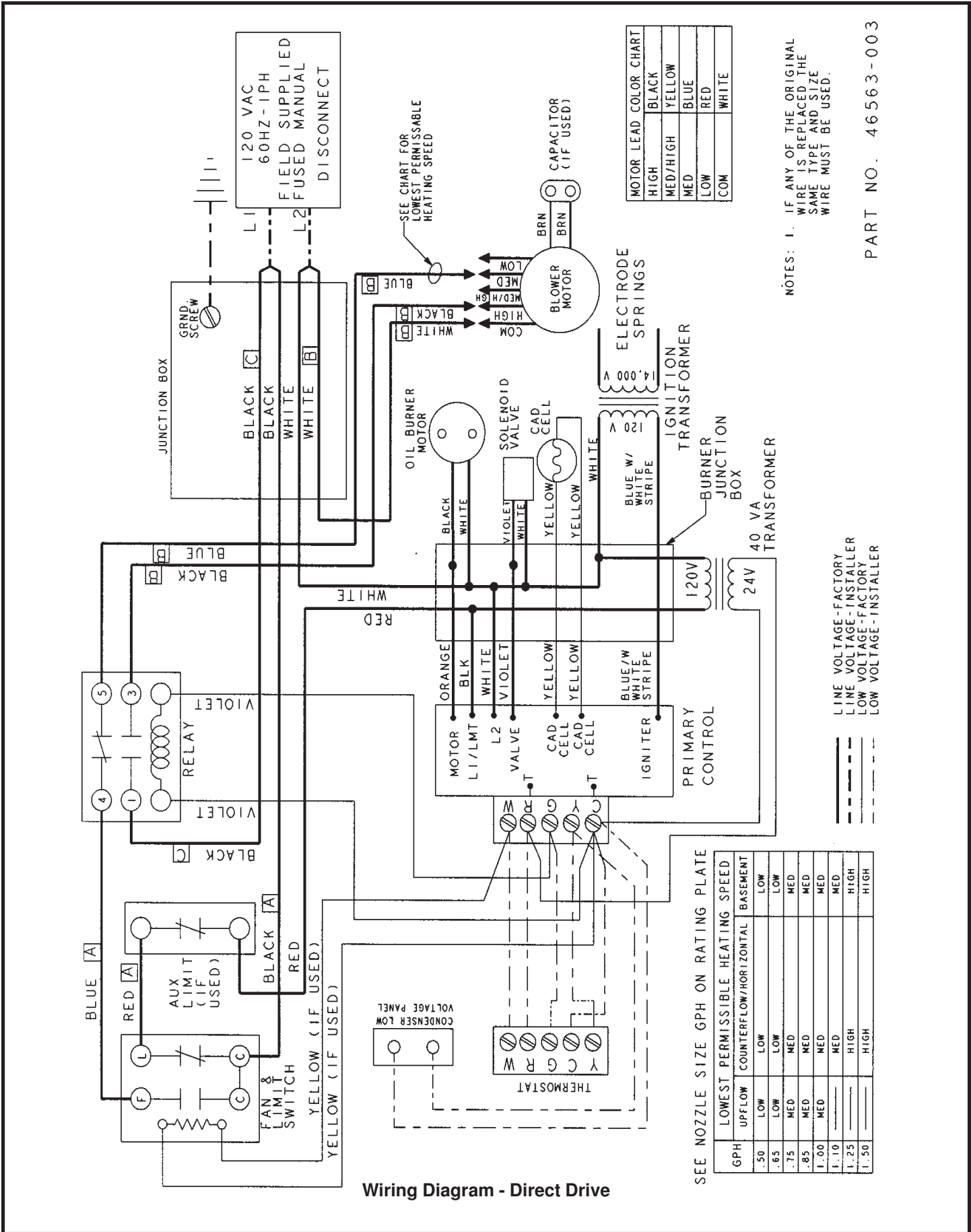

Figure 13



MOTOR LEAD COLOR CHART

HIGH	BLACK
MED/HIGH	YELLOW
MED	BLUE
LOW	RED
COM	WHITE

NOTES: 1. IF ANY OF THE ORIGINAL WIRE IS REPLACED THE SAME TYPE AND SIZE WIRE MUST BE USED.

PART NO. 46563-003

SEE NOZZLE SIZE GPH ON RATING PLATE

GPH	LOW	LOW	LOW	LOW	LOW	LOW	LOW	LOW	LOW
UPFLOW	COUNTERFLOW	HORIZONTAL	BASEMENT	BASEMENT	BASEMENT	BASEMENT	BASEMENT	BASEMENT	BASEMENT
.50	LOW	LOW	LOW	LOW	LOW	LOW	LOW	LOW	LOW
.65	LOW	MED	MED	MED	MED	MED	MED	MED	MED
.75	MED	MED	MED	MED	MED	MED	MED	MED	MED
.85	MED	MED	MED	MED	MED	MED	MED	MED	MED
1.00	MED	MED	MED	MED	MED	MED	MED	MED	MED
1.10	MED	MED	MED	MED	MED	MED	MED	MED	MED
1.25	HIGH	HIGH	HIGH	HIGH	HIGH	HIGH	HIGH	HIGH	HIGH
1.50	HIGH	HIGH	HIGH	HIGH	HIGH	HIGH	HIGH	HIGH	HIGH

LINE VOLTAGE - FACTORY  
 LINE VOLTAGE - INSTALLER  
 LOW VOLTAGE - FACTORY  
 LOW VOLTAGE - INSTALLER

Figure 14



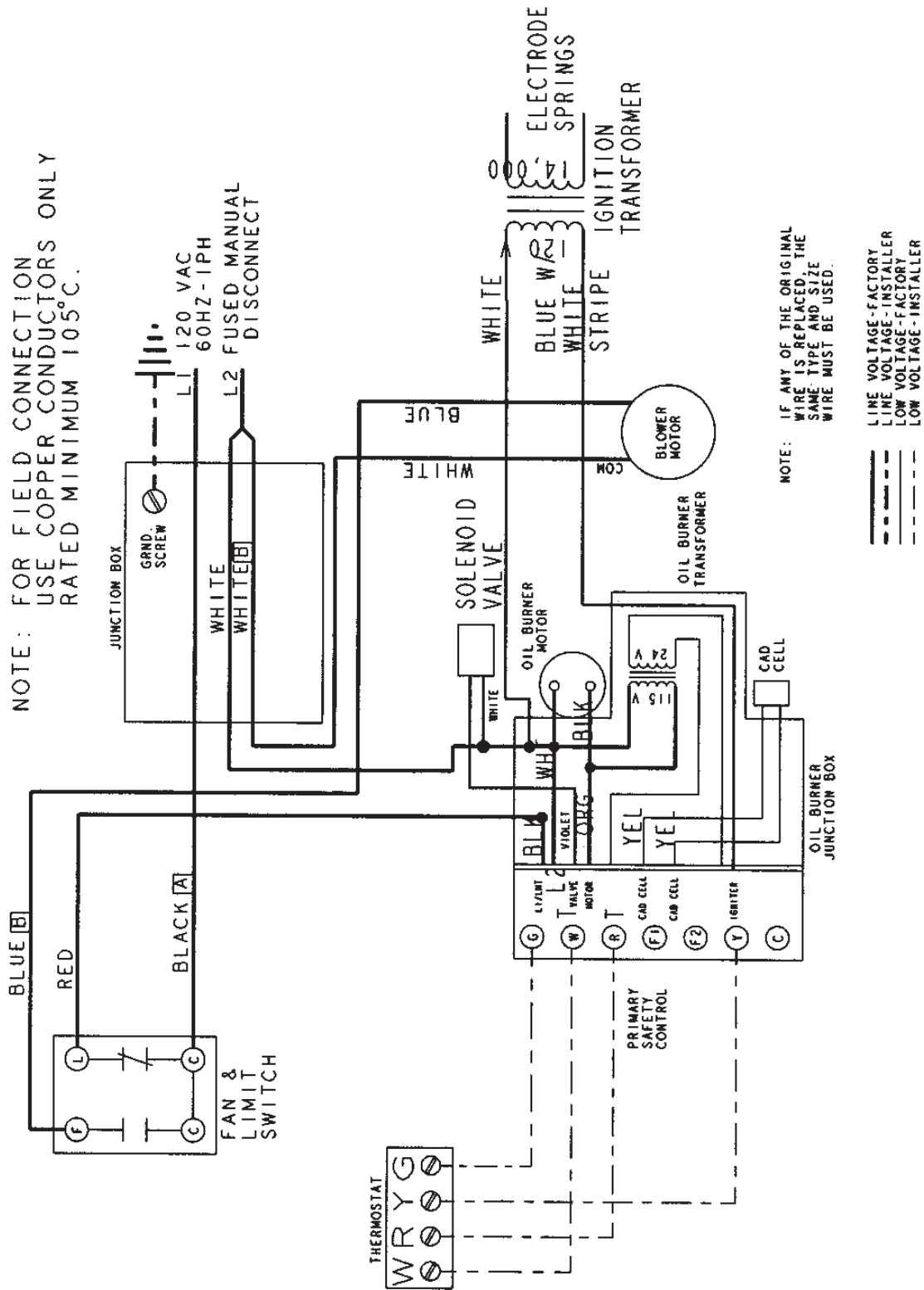

NOTE: FOR FIELD CONNECTION USE COPPER CONDUCTORS ONLY RATED MINIMUM 105°C.

NOTE: IF ANY OF THE ORIGINAL WIRE IS REPLACED, THE SAME TYPE AND SIZE WIRE MUST BE USED.

— LINE VOLTAGE-FACORY  
 - - - LINE VOLTAGE-INSTALLER  
 ···· LOW VOLTAGE-FACORY  
 ···· LOW VOLTAGE-INSTALLER

PART NO. 44130-001

Wiring Diagram  
 Belt Drive - Heating Only

Figure 15

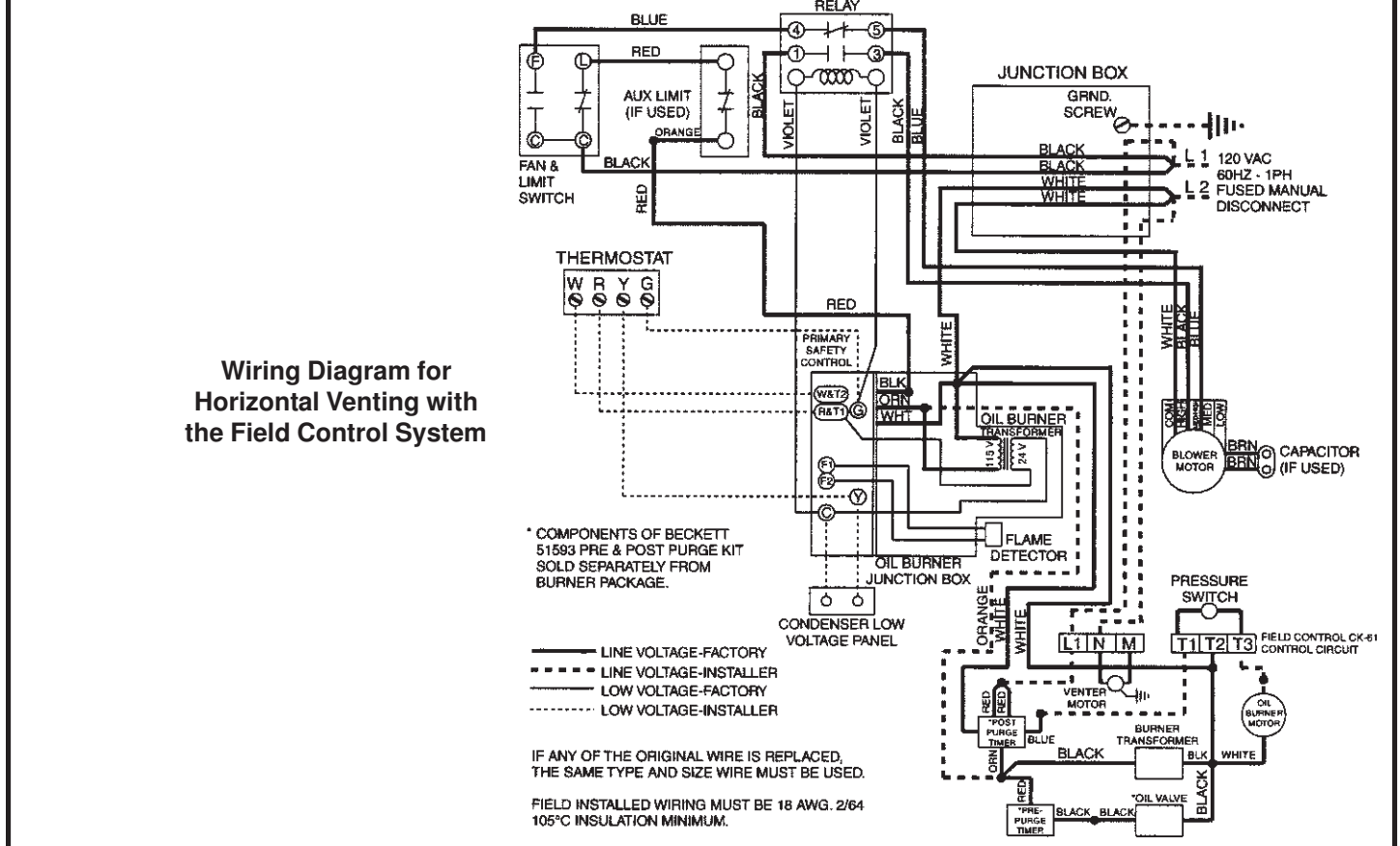
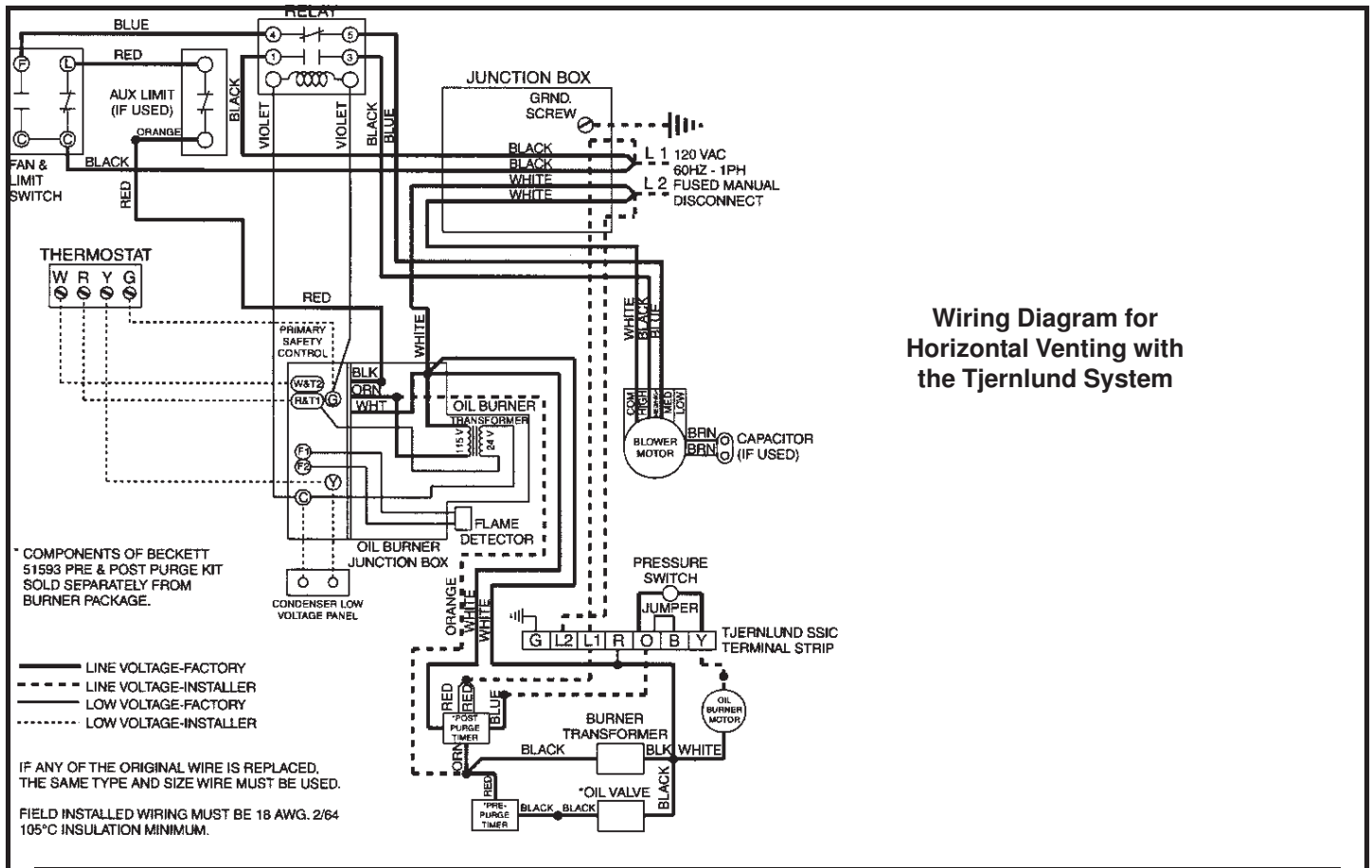

Figure 16