

Installation, Operation and Maintenance

FEDDERS®

MODEL F80A035 F80A050 F80A070
F80A085 F80A100 F80A115 F80A135
CATEGORY I NATURAL GAS AND LP GAS
MID EFFICIENCY WARM AIR FURNACE

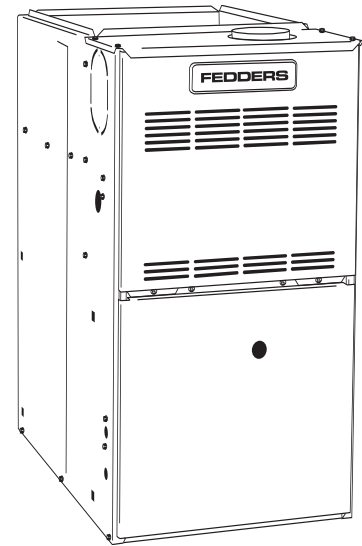

TABLE OF CONTENTS

INTRODUCTION	1
SAFETY	1
CODES	2
FURNACE SIZING	3
LOCATION of UNIT	3
INSTALLATION POSITIONS	4
AIR CONDITIONING	4
INSPECTION/ACCESS PANEL	4
CLEARANCES	5
DIMENSIONS	5
DUCTWORK	6
DETERMING COMBUSTION AIR	7
FURNACE VENTING	8
GAS SUPPLY	13
CONVERSIONS	14
HIGH ALTITUDE & AIRFLOW	
SPECIFICATION TABLES	15
ELECTRICAL SPECIFICATIONS	16
START UP PROCEDURES/	
SEQUENCE OF OPERATION	18
AIR FLOW	20
ADJUSTING BLOWER SPEEDS	20
MAINTENANCE	21
TROUBLESHOOTING	22
WIRING DIAGRAM	26

For future reference write down the model, serial number, and date of purchase. Use these numbers in any correspondence or service calls concerning your furnace.

Model
Serial Number
Date of Purchase

Keep these instructions for future reference.

Please read the operating instructions and safety precautions carefully and thoroughly before installing and operating your furnace. Keep this manual in a safe place for future reference.



**USER'S INSTRUCTION GUIDE
LOCATED AFTER PAGE 26 OF THIS
INSTALLATION, OPERATION AND
MAINTENANCE MANUAL**

MODEL F80A

INTRODUCTION

This gas fired mid-efficiency (non-condensing) furnace is an up flow, counterflow or horizontal flow warm air furnace suitable for residential and light commercial heating applications from 35,000 to 135,000 BTU/Hr.

This appliance is a CGA / AGA design certified as a Category I chimney vent central forced air furnace with all combustion air supplied from the ambient air around the furnace.

Furnace models F80A50, F80A70, F80A85, F80A100, F80A115 and F80A135 may be field converted from natural gas to LP gas using Kit No. 30482, or may be field converted from LP gas to natural gas using Kit No. 30551. Contact manufacturer for conversion kit availability. ***Furnace model F80A35 cannot be converted to LP, and is not approved for conversion.**

The furnace is shipped completely assembled. Please inspect for damage, as the furnace is unpacked.

SAFETY

Throughout the manual, symbols and words are used to draw attention to potentially hazardous conditions.

⚠ DANGER ⚠

THIS INDICATES AN IMMINENTLY HAZARDOUS SITUATION WHICH, IF NOT AVOIDED, WILL RESULT IN DEATH OR SERIOUS INJURY.

⚠ WARNING ⚠

THIS INDICATES A POTENTIALLY HAZARDOUS SITUATION WHICH, IF NOT AVOIDED, COULD RESULT IN DEATH OR SERIOUS INJURY.

⚠ CAUTION ⚠

THIS INDICATES A POTENTIALLY HAZARDOUS SITUATION, WHICH, IF NOT AVOIDED, MAY RESULT IN MINOR OR MODERATE INJURY.

SAFETY RULES:

1. Use this furnace only with type of gas approved for this furnace. Refer to the furnace rating plate.
2. Install this furnace only in dry indoor locations (protected from weather).
3. Provide adequate combustion and ventilation air to the furnace space as specified in the Determining Combustion Air section on page 7 of these instructions.
4. Combustion products must be discharged outdoors. Connect this furnace to an approved vent system only, as specified in the Furnace Venting section on page 8 of these instructions.
5. Never test for gas leaks with an open flame. Use a commercially available soap solution made specifically for the detection of leaks to check all connections as specified in the Gas Supply section on page 13 of these instructions.

6. Always install furnace to operate within the furnace's intended temperature rise range with a duct system which has an external static pressure within the allowable range, as specified in the Furnace Sizing section on page 3, the Ductwork section on page 6, and the Airflow section on page 20 of these instructions
7. When a furnace is installed so that the supply ducts carry air circulated by the furnace to areas outside the space containing the furnace, the return air shall also be handled by duct(s) sealed to the furnace casing and terminating outside the space containing the furnace. (Furnace for heating the home located in the attached garage, for example).
8. A gas fired furnace for installation in a residential garage must be installed so that the burners and ignitor are no less than 18 inches above the floor. The furnace must be located, or protected to avoid physical damage by vehicles.
9. **THIS FURNACE IS NOT TO BE USED FOR TEMPORARY HEATING FOR BUILDINGS UNDER CONSTRUCTION.**
10. Nox Baffles are factory installed in the heat exchanger tubes of this furnace, and must remain installed regardless of fuel being used.

⚠ DANGER ⚠

DO NOT INSTALL THIS FURNACE IN A MOBILE HOME!
THIS FURNACE IS NOT APPROVED FOR INSTALLATION IN A MOBILE HOME. DOING SO COULD CAUSE FIRE, PROPERTY DAMAGE, PERSONAL INJURY OR LOSS OF LIFE.

⚠ WARNING ⚠

THE FURNACE CONTAINS FOIL COVERED FIBERGLASS INSULATION. INHALATION OF FIBERGLASS PARTICLES IS ASSOCIATED WITH RESPIRATORY DISEASE INCLUDING CANCER.

⚠ WARNING ⚠

THE FUEL SUPPLIER NORMALLY ODORIZES NATURAL GAS AND PROPANE. IN SOME CASES, THE ODORANT MAY NOT BE PERCEIVABLE. INSTALLATION OF UL AND CUL RECOGNIZED FUEL GAS DETECTORS INSTALLED IN ACCORDANCE WITH THEIR MANUFACTURER'S INSTRUCTIONS IS RECOMMENDED AS AN ADDITIONAL MARGIN OF SAFETY.

⚠ DANGER ⚠

FIRE OR EXPLOSION HAZARD

If the information in these instructions is not followed exactly, a fire or explosion may result, causing property damage, personal injury or loss of life.

⚠ CAUTION ⚠

MAKE SURE TO REMOVE FOAM BLOWER HOUSING SHIPPING SUPPORTS BEFORE OPERATING FURNACE.
SHIPPING SUPPORTS ARE LOCATED ON THE BOTTOM RIGHT AND BOTTOM LEFT SIDES OF BLOWER HOUSING.

⚠ DANGER ⚠

WHAT TO DO IF YOU SMELL GAS:

- DO NOT TRY TO LIGHT ANY APPLIANCE
- DO NOT TOUCH ANY ELECTRICAL SWITCH; DO NOT USE ANY PHONE IN YOUR BUILDING
- IMMEDIATELY CALL YOUR GAS SUPPLIER FROM A NEIGHBOR'S PHONE, OR A CELLULAR PHONE FROM A LOCATION WELL AWAY FROM THE BUILDING. FOLLOW THE GAS SUPPLIER'S INSTRUCTIONS.
- IF YOU CANNOT REACH YOUR GAS SUPPLIER, CALL THE FIRE DEPARTMENT
- DO NOT ENTER THE BUILDING UNTIL AUTHORIZED TO DO SO BY THE GAS SUPPLIER OR THE FIRE DEPARTMENT

IMPROPER INSTALLATION, OPERATION, ADJUSTMENT, ALTERATION, SERVICE OR MAINTENANCE CAN CAUSE INJURY, PROPERTY DAMAGE OR LOSS OF LIFE. REFER TO THIS MANUAL FOR PROPER INSTALLATION, OPERATION, SERVICE, AND MAINTENANCE INSTRUCTIONS.

A QUALIFIED INSTALLER, SERVICE AGENCY OR THE GAS SUPPLIER MUST PERFORM INSTALLATION AND SERVICE.

DO NOT DESTROY THIS MANUAL

PLEASE READ CAREFULLY AND KEEP IN A SAFE PLACE FOR FUTURE REFERENCE BY A SERVICE TECHNICIAN.

⚠ WARNING ⚠

THESE INSTRUCTIONS ARE INTENDED AS AN AID TO QUALIFIED SERVICE PERSONNEL FOR PROPER INSTALLATION, ADJUSTMENT AND OPERATION OF THIS FURNACE. READ THESE INSTRUCTIONS THOROUGHLY BEFORE ATTEMPTING INSTALLATION OR OPERATION. FAILURE TO FOLLOW THESE INSTRUCTIONS MAY RESULT IN IMPROPER INSTALLATION, ADJUSTMENT, SERVICE OR MAINTENANCE, POSSIBLY RESULTING IN FIRE, ELECTRICAL SHOCK, CARBON MONOXIDE POISONING, EXPLOSION, PROPERTY DAMAGE, PERSONAL INJURY OR DEATH.

DO NOT STORE OR USE GASOLINE OR OTHER FLAMMABLE VAPORS AND LIQUIDS, OR OTHER COMBUSTIBLE MATERIALS IN THE VICINITY OF THIS OR ANY OTHER APPLIANCE.

⚠ WARNING ⚠

THE EXHAUST GASES FROM THIS FURNACE CONTAIN CHEMICALS, WHICH ON SOME OCCASIONS MAY INCLUDE CARBON MONOXIDE (CO). CARBON MONOXIDE IS AN ODORLESS, TASTELESS, CLEAR COLORLESS GAS, WHICH IS HIGHLY TOXIC. EVEN LOW CONCENTRATIONS ARE SUSPECTED OF CAUSING BIRTH DEFECTS AND OTHER REPRODUCTIVE HARM.

UL AND CUL RECOGNIZED CO DETECTORS ARE RECOMMENDED FOR ALL BUILDINGS EQUIPPED WITH FOSSIL FUEL BURNING APPLIANCES. ALL CO DETECTORS SHOULD BE INSTALLED IN ACCORDANCE WITH THEIR MANUFACTURER'S INSTRUCTIONS AND APPLICABLE LOCAL BUILDING CODES.

⚠ DANGER ⚠

WHEN THIS FURNACE IS INSTALLED IN A RESIDENTIAL GARAGE, IT MUST BE INSTALLED SO THE BURNERS AND IGNITION SOURCE ARE LOCATED NO LESS THAN 18 INCHES ABOVE THE FLOOR TO PREVENT THE RISK OF IGNITING FLAMMABLE VAPORS WHICH MAY BE PRESENT IN THE GARAGE.

THE FURNACE MUST BE LOCATED OR PROTECTED TO AVOID PHYSICAL DAMAGE BY VEHICLES.

FAILURE TO HEED THESE WARNINGS CAN CAUSE A FIRE OR EXPLOSION, RESULTING IN PROPERTY DAMAGE, PERSONAL INJURY OR LOSS OF LIFE.

CODES:

This furnace must be installed:

- In accordance with all local codes, bylaws and regulations by those authorities having jurisdiction
- In the United States, this furnace must be installed in accordance with the current ANSI Z223.1 (NFPA 54) National Fuel Gas Code
- In Canada, this furnace must be installed in accordance with the current CAN/CGA -B149 Installation Code for Fuel Burning Appliances

Electrical connections must be made in accordance with:

- Any applicable local codes, bylaws and regulations
- Canada: current edition of CAN/CSA C22.1, Canadian Electrical Code (Part 1)
- United States: current edition of ANSI/NFPA 70, National Electrical Code

Codes and additional information may be obtained from:

- American Gas Association
1515 Wilson Boulevard
Arlington, VA, 22209
703-841-8400
- National Fire Protection Association
1 Batterymarch Park
Quincy, MA, 02269-9101
617-770-3000
- Canadian Gas Association
Suite 1, 243 Consumers Road
North York, ON, M2J 5E3
416-498-1994

FURNACE SIZING

The maximum hourly heat loss for each heated space shall be calculated in accordance with the procedures described in Manual J titled, "Load Calculation" published by the Air Conditioning Contractors of America, or by any other method which is suitable for local conditions, provided the results obtained are in substantial agreement with, and not less than those obtained using the procedure described in their manual.

In Canada, the maximum hourly heat loss for each heated space shall be calculated in accordance with the procedures described in the manuals of the Heating, Refrigeration and Air Conditioning Institute of Canada (HRAI), or by any other method which is suitable for local conditions, provided the results obtained are in substantial agreement with, and not less than those obtained using the procedure described in their manuals.

If the installation is a retrofit application, do not rely on the capacity of the existing heating equipment as a method to size the new furnace. Many of the heat transfer multiples listed in earlier versions of load calculation manuals were much higher than those listed in more recent editions. It is possible that energy saving measures have been completed since the installation of the existing furnace. This might include additional insulation in the attic or walls, the application of sprayed foam insulation, the addition of storm windows and doors, weather stripping, caulking, etc.

Many of the older furnaces were equipped with large belt drive blower systems, operating at low RPMs. If replacing an existing furnace, be sure that the existing ductwork can handle the amount of airflow necessary for a reasonable temperature rise. Most older gas furnaces operated with a system temperature rise of 70 - 100°F. This series furnace has been designed for operation with a system temperature rise (DT) of 35 - 65°F or 30 - 60°F depending on which model is being installed. See Table 1A below. If the furnace selected has an identical output capacity as the original furnace, a substantial increase in system airflow will be required. See Table 1B below.

TABLE 1A FURNACE TEMPERATURE RISE		TABLE 1B TYPICAL AIR FLOW				
Furnace Model	Temperature Rise	CFM Required for a ΔT of:				
		Model	35	45	55	65
35-2	35 - 65 F	35-2	737	574	469	397
50-3		50-3	1053	819	670	567
70-3		70-3	1433	1114	912	771
70-4	30 - 60 F	70-4	1433	1114	912	771
85-3	35 - 65 F	85-3	1791	1393	1140	964
85-4	30 - 60 F	85-4	1791	1393	1140	964
100-3	35 - 65 F	100-3	2107	1639	1341	1134
100-4		100-4	2107	1639	1341	1134
100-5	30 - 60 F	100-5	2107	1639	1341	1134
115-5		115-5	2423	1884	1542	1305
135-5	30 - 65 F	135-5	2844	2212	1810	1532

Existing ductwork should be assessed for its air handling capabilities. For residential applications, the recommended air velocity of a supply air trunk duct is 700 feet per minute (fpm), and should not exceed 900 fpm. The recommended air velocity of a supply air branch run is 600 fpm, and should not exceed 900 fpm. These values are slightly lower for flexible ducting. The recommended air velocity of a return air trunk duct is 600 fpm, and should not exceed 700 fpm. The recommended and maximum air velocity of a return air branch is 600 fpm.

The equal friction chart, as published by ASHRAE and HRAI, is the basis for the various air duct calculators available through heating supply companies.

NOTE: The return air system is equally as important as the supply air system. An undersized return air system will prevent sufficient quantities of air from reaching the supply air system, properly sized or otherwise, and will consequently reduce the service life of the furnace and its components.

LOCATION of UNIT

GENERAL:

1. The furnace is not weatherized. Select a dry indoor location.
2. Select a location where the furnace venting can be routed between the furnace and the chimney or B-Vent with a minimum of lengths and fittings. Be sure to check that the proposed routing will meet code requirements with respect to minimum clearances.
3. Select a location as near as possible to the existing or proposed duct system.
4. The furnace location must permit access for servicing, and be within the clearance to combustibles guidelines as marked on the appliance rating plate.
5. The furnace should be installed on a firm base when installed in the upflow position. This is typically a concrete floor if installing the furnace in a basement.
6. If the furnace is being installed so that the return air will enter through the bottom, the perimeter of the furnace must be properly supported.
7. When installed in the horizontal position, the furnace may be supported from the bottom, or suspended.
8. When installed in the down flow position on a combustible floor, subbase kit #30476 is required (contact manufacturer for availability).

OTHER CONSIDERATIONS:

- This furnace is not to be used for temporary heating of buildings or structures under construction.
- If this furnace is to be used with air conditioning and is to be installed in an area over a finished ceiling or living area, install a field fabricated auxiliary drain pan under the furnace to protect that area from accidental condensate spills. The auxiliary pan should be large enough to collect accidentally spilled condensate from the air conditioning evaporator coil assembly if applicable. Follow local codes.
- These furnaces are approved for installation in attics, alcoves, utility rooms, closets and crawlspaces. If this furnace is to be installed in a utility room, be sure that it is located in such a way as to allow access for servicing or the removal of any other appliance, (hot water heater, for example).
- If the furnace is to be installed in a garage, the burners must be a minimum of 18 inches (460 mm) above the floor.
- If the furnace is to be installed in a commercial (repair) garage, the burners must be a minimum of 4.5 feet (1375 mm) above the floor.
- The furnace must be protected from physical damage by metal barriers or other acceptable means.

- If the furnace is to be located in an area where the combustion air is laden with chemical compounds such as bromine, chlorine or fluorine, as may be found in swimming pool chemicals, laundry detergents, etc., use outdoor air for combustion. These compounds when exposed to flame, form acids, which attack the heat exchanger and other components.

A partial list of these contaminants includes:

- Aerosols, particularly CFC based aerosols
- Air fresheners
- "Airplane" glue and similar cements
- Ammonia, as is commonly found in permanent wave solutions used in women's hair dressing salons
- Anti-static fabric softeners used in clothes dryers
- Carbon tetrachloride
- Chlorinated cleaners and waxes
- Chlorine and bromine based swimming pool chemicals and treatments
- Deicing salts or chemicals, rock salt, etc.
- Dry cleaning solutions such as perchloroethylene
- Halogen based refrigerants including R-12 and R-22
- Hydrochloric acid, muriatic acid, or other acid based masonry washing compounds
- Polyurethane and similar derivatives fumes
- Printer's inks, paint removers, furniture strippers, varnishes, varsol, toluene, etc.
- Water softener salts and chemicals

INSTALLATION POSITIONS

NONSUSPENDED INSTALLATION

Maintain clearances to combustibles as outlined in Table 2 on page 5. The furnace must be supported in such a way as to not allow twisting or sagging of the cabinet.

SUSPENDED INSTALLATION

Refer to Figure 1 (below). Maintain clearances to combustibles as outlined in Table 2 on page 5. The furnace may be suspended by field fabricating a cradle of angle iron and threaded rod. Secure the furnace with 2 inch minimum slotted angle or equivalent, as shown in Figure 1 (below). The furnace must be supported in such a way as not to allow twisting or sagging of the cabinet. Position the supports so as not to interfere with accessing the burner and blower compartments.

FIGURE 1: SUSPENDED INSTALLATION

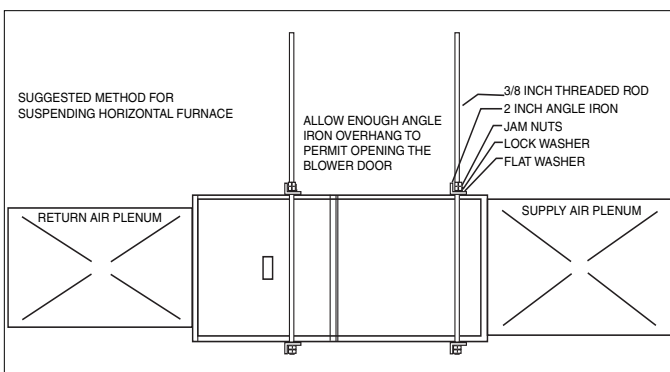

UPFLOW INSTALLATION

This furnace comes assembled for installation in the upflow position and ready for vertical venting. In the event that the furnace will be installed in another position, the following guidelines should be followed.

COUNTERFLOW INSTALLATION

⚠ WARNING ⚠

WHEN INSTALLED IN THE COUNTERFLOW POSITION ON A COMBUSTIBLE FLOOR, SUBBASE KIT #30476 IS REQUIRED. FAILURE TO INSTALL SUBBASE KIT COULD RESULT IN FIRE, DEATH OR SERIOUS INJURY.

The opening in the floor must provide adequate clearances to the combustible material.

According to the Clearances to Combustibles Table 2 on page 5, 1/2 inches clearance will be required between the plenum and the combustible material. If installed on a non-combustible material, zero clearance is required.

Inducer position changes required shall be performed in accordance with the inducer rotation instructions in the Furnace Venting section on page 8 of this manual. In the counterflow installation, this furnace can only vent through the left or right side of the furnace.

HORIZONTAL INSTALLATION

Inducer position changes required shall be performed in accordance with the inducer rotation instructions in the Furnace Venting section on page 8 of this manual. In the horizontal installation, it is not permissible to vent downwards. Therefore the orientation of left or right horizontal position will determine the inducer orientation.

NOTE: It is not permissible to use a rear return on this furnace although side and end returns may be used.

AIR CONDITIONING

This furnace may be used as part of an air conditioning system. The furnace wiring and control system are "air conditioning ready". There are the following factors to consider:

- The air conditioning evaporator coil must be downstream of the heat exchanger. The cooled air passing over the warm ambient air inside the heat exchanger tubes can cause condensation inside the tubes, resulting in corrosion and premature failure.
- A parallel duct system can be installed to direct the air from the furnace through the evaporator coil only. Use dampers or other means to bypass the heat exchanger. If [summer/winter] dampers are used, they should be interlocked to prevent system operation unless the dampers are in the full open or full closed position.

INSPECTION / ACCESS PANEL

If an air conditioning coil is not to be used in the supply air plenum, it is recommended that the outlet duct be provided with a removable access panel, which is accessible when installed so the heat exchanger may be viewed for possible openings using light assistance or a probe that can be inserted for sampling the air stream. The access cover must be fabricated in such a manner as to prevent leaks.

MODEL F80A

CLEARANCES

Table 2 (below) provides the certified clearances to combustibles.

IMPORTANT:

This furnace requires a minimum of 24-inches of front clearance for service purposes. For this purpose, service clearance takes precedence over clearance to combustibles.

TABLE 2: CLEARANCES TO COMBUSTIBLES

	UPFLOW	COUNTERFLOW	HORIZONTAL
UNIT TOP	1"	0"	2"
PLENUM TOP/BOTTOM	1"	1"	2.5"
PLENUM SIDES	.5"	.5"	.5"
UNIT FRONT	3.5**	3.5**	3.5**
UNIT BACK	0"	0"	0"
UNIT SIDES	0"	0"	1***
UNIT BASE	0****	0****	0"
FLUE PIPE	C VENT	6"	6"
	B VENT	1"	1"
ENCLOSURE	CLOSET CABINET	CLOSET CABINET	CLOSET CABINET

* 24 inches required for service

** Supply air end 1 inch / return air end 0 inches

*** Certified for closet installation on combustible flooring

**** Certified for installation on combustible flooring only when installed on special base (part # 30476).

See the appliance rating plate affixed to the furnace for specific model number, serial number and clearance to combustibles information.

⚠ DANGER ⚠

COMBUSTIBLE MATERIAL MUST NOT BE PLACED ON OR AGAINST THE FURNACE JACKET.

THE AREA AROUND THE FURNACE MUST BE KEPT CLEAR AND FREE OF ALL COMBUSTIBLE MATERIALS INCLUDING GASOLINE AND OTHER FLAMMABLE VAPORS AND LIQUIDS.

PLACEMENT OF COMBUSTIBLE MATERIALS ON, AGAINST OR AROUND THE FURNACE JACKET CAN CAUSE AN EXPLOSION OR FIRE RESULTING IN PROPERTY DAMAGE, PERSONAL INJURY OR LOSS OF LIFE.

THE HOMEOWNER SHOULD BE CAUTIONED THAT THE FURNACE AREA MUST NOT BE USED AS A BROOM CLOSET OR FOR ANY OTHER STORAGE PURPOSE.

UPFLOW FURNACES ARE DESIGN CERTIFIED FOR INSTALLATION ON COMBUSTIBLE FLOORS. THIS SHALL BE INTERPRETED AS A WOOD FLOOR ONLY.

THE FURNACE MUST NOT BE INSTALLED DIRECTLY ON CARPETING, VINYL TILE, OR OTHER COMBUSTIBLE MATERIAL EXCEPT WOOD. INSTALLATION ON COMBUSTIBLE MATERIAL CAN RESULT IN FIRE, CAUSING PROPERTY DAMAGE, PERSONAL INJURY OR DEATH.

FIGURE 2: DIMENSIONS

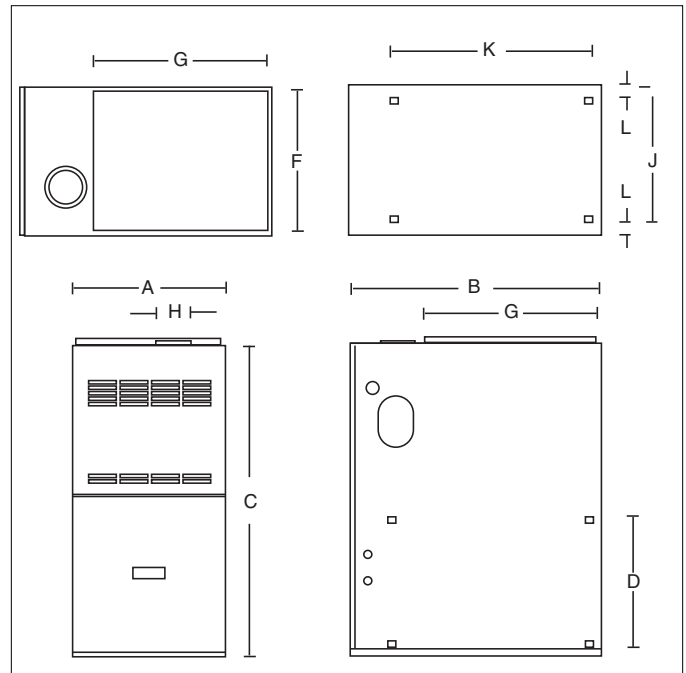

TABLE 3: DIMENSIONS

DIMENSIONS (Inches)				
MODEL	WIDTH	DEPTH	HEIGHT	SUPPLY
	A	B	C	F x G
35-2 50-3	14-1/2	29	35	13-1/2 x 19
70-3	16	29	35	15 x 19
70-4 85-3	17-1/2	29	35	16-1/2 x 19
85-4 100-3 100-4	20-1/2	29	35	19-1/2 x 19
100-5	20-1/2	29	35	19-1/2 x 19
115-5	22	29	35	21 x 19
135-5	22	29	35	21 x 19

MODEL	RETURN			VENT
	SIDE	BOTTOM		
	D x E	J x K	L	H
35-2 50-3	14 x 22	13-1/2 x 22	1/2	3 ¹
70-3	14 x 22	14-1/2 x 22	3/4	4
70-4	14 x 22 ²	14-1/2 x 22	1-1/2	4
85-3	14 x 22	14-1/2 x 22	1-1/2	4
85-4 100-3 100-4	14 x 22	16 x 22	2-1/4	4
100-5	14 x 22 ²	16 x 22	2-1/4	4
115-5	14 x 22 ²	19 x 22	1-1/2	5 ¹
135-5	14 x 22 ²	19 x 22	1-1/2	5 ¹

¹ Vent outlet 4" - Use reducer fittings.

² Two return air openings required

DUCTWORK

Proper airflow is required for the correct operation of this furnace. Insufficient airflow may cause erratic operation, could cause the furnace to cycle on the high temperature limit, and may damage the heat exchanger. Excessive airflow may result in an excessively noisy duct system and may result in undesirable consequences such as creating uncomfortable drafts and causing drapes or curtains to blow around.

If air conditioning is to be used with the furnace, the duct system must be capable of delivering the correct amount of airflow for each system.

The ductwork should be sized and constructed in accordance with accepted industry standards. Duct sizing and construction information may be obtained from:

- A.C.C.A. (Air Conditioning Contractors of America)
- A.S.H.R.A.E. (American Society of Heating, Refrigeration and Air Conditioning Engineers)
- H.R.A.I. (Heating, Refrigerating and Air Conditioning Institute (Canada))
- S.M.A.C.N.A. (Sheet Metal and Air Conditioning Contractors' National Association (United States))

All of the above professional organizations have duct sizing manuals available.

The total static pressure drop of the air distribution system should not exceed 0.5 inches water column.

NOTE:

UNITS 70-4, 100-5, 115-5 AND 135-5 MUST HAVE DUAL RETURN AIR INLETS FOR OPTIMAL AIRFLOW AND AIR FILTRATION. IF NOT SPECIFICALLY STATED BY THE FILTER MANUFACTURER, FOR EFFECTIVE AIR FILTRATION, ASSUME A MAXIMUM VELOCITY OF 300 FPM FOR DISPOSABLE TYPE FILTERS, OR 600 FPM FOR PERMANENT TYPE FILTERS.

GUIDE:

Filter free area (in²) = 144 x (CFM / desired velocity (fpm))

IMPORTANT: Some high efficiency filters have a greater than normal resistance to airflow. This can adversely affect furnace operation. Ensure to check the airflow when using any filter.

⚠ WARNING ⚠

DO NOT, UNDER ANY CIRCUMSTANCES, CONNECT RETURN OR SUPPLY AIR DUCTWORK TO OR FROM ANY OTHER HEAT-PRODUCING DEVICE SUCH AS A FIREPLACE INSERT, STOVE, ETC. DOING SO MAY RESULT IN FIRE, CARBON MONOXIDE POISONING, EXPLOSION, PERSONAL INJURY, LOSS OF LIFE, OR PROPERTY DAMAGE.

DUCTWORK STEPS:

1. Position the furnace to minimize ductwork length and fittings.
2. Cut open a return air inlet. The choices are:
 - a) either side
 - b) furnace bottom
 - c) any combination, i.e. two sides or a side and the bottom. Note: 2 return openings required for 70-4, 100-5, 115-5 and 135-5.

⚠ CAUTION ⚠

DO NOT USE THE REAR PANEL AS A RETURN AIR INLET. THERE IS INSUFFICIENT ROOM TO PERMIT ADEQUATE AIRFLOW.

In all cases, cut the inlet air opening the full width of the knockouts.

NOTE: When two return air inlets are used, both must be equipped with filters.

3. Install the filter rack(s) (field supplied).
4. Connect the return air duct or fitting to the furnace. The connection should be as air tight as possible to prevent entraining combustion gases from an adjacent fuel burning appliance, or entraining combustion air for this furnace .
5. Ensure that there is adequate space and accessibility for the air filter.
6. If an air conditioning evaporator coil is required, position it on the top of the furnace. Ensure that no air can bypass the evaporator coil.
7. Connect the supply air plenum to the supply air outlet. Flexible duct connectors are an effective device to prevent the telegraphing of mechanical noise from the furnace to other parts of the home via the ductwork. If using flexible connectors, ensure that the adjoining duct is independently supported.

Adequate provisions for combustion and ventilation air must be in accordance with ANSI Z223.1 (NFPA 54), section 5.3 "Air for Combustion and Ventilation" in the United States, and CAN/CGA B149 in Canada. Check with local authorities for any additional building codes, bylaws or regulations.

⚠ WARNING ⚠

NEVER ALLOW THE PRODUCTS OF COMBUSTION FROM THE FLUE TO ENTER THE RETURN AIR OR SUPPLY AIR DUCTWORK.

ALL RETURN AIR DUCTWORK MUST BE ADEQUATELY SEALED AND SECURED TO THE FURNACE WITH SHEET METAL SCREWS. TAPE THE SHEET METAL SEAMS IN THE VICINITY OF THE FURNACE WITH DUCT TAPE OR SIMILAR MATERIAL.

WHEN THE FURNACE IS MOUNTED ON A PLATFORM WITH RETURN AIR THROUGH THE BOTTOM, IT MUST BE SEALED AIR TIGHT BETWEEN THE FURNACE AND THE RETURN AIR PLENUM. THE FLOOR OR PLATFORM MUST PROVIDE SOUND PHYSICAL SUPPORT OF THE FURNACE WITHOUT SAGGING, CRACKS OR GAPS AROUND THE BASE, PROVIDING A SEAL BETWEEN THE SUPPORT AND THE BASE.

FAILURE TO PREVENT PRODUCTS OF COMBUSTION FROM BEING CIRCULATED INTO THE LIVING SPACE CAN CREATE POTENTIALLY HAZARDOUS CONDITIONS, INCLUDING CARBON MONOXIDE POISONING THAT COULD RESULT IN PERSONAL INJURY OR DEATH.

DETERMING COMBUSTION AIR

DANGER

READ, UNDERSTAND AND FOLLOW ALL INSTRUCTIONS IN THIS SECTION. FAILURE TO PROPERLY VENT OR SUPPLY COMBUSTION AIR TO THIS FURNACE CAN CAUSE CARBON MONOXIDE POISONING, OR AN EXPLOSION OR FIRE, RESULTING IN PROPERTY DAMAGE, PERSONAL INJURY OR LOSS OF LIFE.

DANGER

THIS FURNACE AND ANY OTHER FUEL BURNING APPLIANCE MUST BE PROVIDED WITH ENOUGH FRESH AIR FOR PROPER COMBUSTION AND VENTILATION OF THE FLUE GASES. MOST HOMES WILL REQUIRE THAT OUTSIDE AIR BE BROUGHT TO THE FURNACE AREA. FAILURE TO DO SO CAN CAUSE PERSONAL INJURY OR DEATH FROM CARBON MONOXIDE POISONING.

CASE 1:

FURNACE LOCATED IN AN UNCONFINED SPACE

Unconfined space does not necessarily mean that combustion and ventilation will not have to be introduced from the outdoors, particularly in airtight homes. Refer to the appropriate installation code requirements regarding the minimum combustion air required for all fuel burning appliances located within the unconfined area.

If the amount of combustion and ventilation air is insufficient to properly operate the furnace and other fuel burning appliances within the unconfined area, it will be necessary to supply it from the outdoors based on the criteria used when calculating the air supply for a confined space.

NOTE: If planning to use the inside air of an unconfined space, remember to test for proper furnace operation (as well as other fuel burning appliances located within the unconfined space) with respect to adequate combustion and ventilation air with fireplace dampers open, clothes dryer running, bathroom exhaust fans on, kitchen range hood on, etc.

CASE 2:

FURNACE LOCATED IN A CONFINED SPACE

A confined space, (any space smaller than the minimums discussed in CASE 1), must have two air openings one within 12 inches of the ceiling and the other within 12 inches of the floor. The air openings must be sized based on whether the combustion and ventilation air is being taken from indoors or outdoors, the method outdoor air (if used) is introduced, and taking into account any other fuel burning appliances in the confined space.

If sufficient indoor combustion and ventilation air is available for the furnace and all other fuel burning appliances, even when clothes dryers, bathroom fans, range hoods, etc. are running, size each opening according to the appropriate installation codes.

NOTE: If using grilles to cover the two openings, factor in the free area of the grille. Typically, a grille will have a free area approximately 50% of its nominal size. Consequently, if the required opening is 10 inches x 10 inches, it will have to be doubled if using a sidewall grille with 50% free area.

IMPORTANT: If an exhaust fan, fireplace, clothes dryer or any similar device is present in the indoor area from which the combustion and ventilation air will be drawn, negative pressure could be a problem if natural infiltration from the outdoors does not match the rate at which air is exhausted.

CASE 3:

FURNACE LOCATED IN A CONFINED SPACE, OUTDOOR AIR FROM ATTIC OR CRAWL SPACE

In this circumstance, refer to the appropriate installation code for the free area of the combustion and ventilation air openings. If other fuel burning appliances are present, their combustion air and ventilation air requirements must be added to those of the furnace.

CASE 4:

FURNACE LOCATED IN A CONFINED SPACE, OUTDOOR AIR DUCTED HORIZONTALLY

Similar to CASE 3, outdoor air for combustion and ventilation may be drawn through horizontal ducting. Consult the appropriate installation code for the free area for openings. If other fuel burning appliances are present, their combustion air and ventilation air requirements must be added to those of the furnace.

IMPORTANT: The outdoor grilles must be installed in a location where they will not be obstructed in any manner.

IMPORTANT: If grilles are used on the outside wall, they must be sized properly. Most sidewall grilles have only 50% free area, so the grill size opening must be twice the size of the free air opening requirement.

WARNING

DO NOT ALLOW GAS PIPING TO BE ROUTED THROUGH JOIST SPACES THAT ARE USED FOR RETURN AIR PURPOSES. DO NOT USE JOIST SPACES FOR RETURN AIR PURPOSES IF THE JOIST SPACE ALREADY CONTAINS PLUMBING STACKS, CHIMNEY COMPONENTS, ETC. UNLESS THE PORTION USED FOR RETURN AIR PURPOSES CAN BE COMPLETELY ISOLATED FROM PORTIONS WITH OTHER USAGES.

FURNACE VENTING

DEFINITIONS

"Vent" and "Chimney" refer to open passageways that convey vent gases from the furnace, or its vent connector, to the outside. Vents and chimneys usually run vertically or nearly vertically. When they serve only one gas appliance, they are called "dedicated" vents or chimneys. When they serve multiple gas appliances, they are called "common" vents or chimneys.

"Vent Connector" refers to a pipe or duct that connects the furnace to a vent or chimney. Vent connectors usually run from the furnace's vent collar to the vent or chimney. Vent connectors may have vertical and horizontal runs.

"Venting System" refers to a continuous open passageway from the vent collar to the outside. Venting systems usually have a vent connector(s) and a vent or chimney. Venting systems commonly serve a single furnace, or a single furnace and a hot water heater. Other multiple appliance venting systems are less common.

"Fan Assisted Combustion System" refers to an appliance equipped with an integral mechanical means to either draw or force products of combustion through the combustion chamber and/or heat exchanger. This series furnace uses a draft inducer to draw combustion products through the heat exchanger and is considered to have a fan assisted combustion system. Category I furnaces with fan assisted combustion systems must not be vented into single wall metal vents.

DESIGN CONSIDERATIONS

The furnace is design certified as a Category I appliance, which means that the furnace relies on the buoyancy of combustion products to vent properly. Since buoyancy decreases proportionately with temperature, the chimney size and properties are very important. An oversized chimney, or one that is exposed to the cold will not maintain the required buoyancy as well as it should, and may allow excessive condensation to form.

IMPORTANT: Do not common vent the furnace with Category III or IV gas-fired appliances.

The furnace must be vented in accordance with these instructions, the Venting Tables and rules published in the current editions of ANSI Z223.1 / NFPA 54, National Fuel Gas Code in the United States, or B149, Natural Gas and Propane Installation Code in Canada, and within the requirements of the codes of the local authority having jurisdiction.

Refer to section 5.3 of ANSI Z223.1/NFPA 54 or sections 7.2, 7.3 or 7.4 of CSA B149 for venting requirements.

The furnace is not equipped with a draft hood to introduce dilution air to the chimney. The products of combustion will therefore have a higher concentration of water vapor within them. If the furnace is the only appliance served by the chimney, a tiled masonry chimney, regardless of tile size, must not be used without a suitably sized certified chimney liner and termination. Consider dedicated venting with a B Vent used as a liner in this case. See Dedicated Venting on page 12.

Multistory and common venting with other Category I gas fired appliances is permitted. The venting system must be in accordance with the National Gas Code, B149 in Canada, ANSI Z223.1/NFPA 54 in the United States, local codes, and approved engineering practices.

⚠ CAUTION ⚠

Combustion air must be free of acid forming chemicals such as sulphur, fluorine and chlorine. These elements are found in aerosol sprays, detergents, bleaches, cleaning solvents, air fresheners, paint and varnish removers, refrigerants, and many other commercial and household products.

When burned in a gas flame, vapors from these products form acid compounds. Acid compounds increase the dew point temperature of the flue products and are highly corrosive after they condense.

Any furnace failure caused by corrosive elements is excluded from warranty coverage.

The following types of installation sites (but not limited to the following) will require OUTDOOR AIR for combustion because of chemical exposures: commercial buildings, buildings with indoor swimming pools, furnaces installed in laundry rooms, furnaces in hobby or craft rooms, furnaces installed near chemical storage areas.

Exposure to the following substances in the combustion air supply (but not limited to the following) will also require OUTDOOR AIR for combustion:

- Aerosols, particularly CFC based or propelled aerosols
- Air fresheners
- Airplane Glue and similar adhesives and cements
- Ammonia, as commonly found in permanent wave solutions used in hair dressing salons
- Antistatic fabric softeners used in clothes dryers
- Carbon tetrachloride
- Chlorinated cleaners and waxes
- Chlorine and bromine based swimming pool chemicals
- Deicing salts or chemicals, e.g. rock salt, etc.
- Dry cleaning fluids such as perchloroethylene
- Fumes from curing polyurethane and similar substances
- Halogen based refrigerants including R-12 and R-22
- Hydrochloric acid, muriatic acid and other acid based masonry washing and curing materials
- Printer's inks, paint removers, varnishes, varsol, toluene, etc.
- Water softener salt and chemicals

⚠ WARNING ⚠

SELECT APPROPRIATE VENTING MATERIALS AND ENSURE PROPER CLEARANCES TO COMBUSTIBLES. INADEQUATE VENTING OR FAILURE TO MAINTAIN PROPER CLEARANCES TO COMBUSTIBLES MAY ALLOW THE ACCUMULATION OF THE PRODUCTS OF COMBUSTION WITHIN THE BUILDING RESULTING IN FIRE, NAUSEA, OR ASPHYXIATION.

DO NOT USE AN UNLINED MASONRY CHIMNEY TO VENT THIS FURNACE. THE USE OF AN UNLINED MASONRY CHIMNEY INCREASES THE RISK OF CONDENSATE FORMATION, WHICH MAY CAUSE THE CHIMNEY TO DETERIORATE, ALLOWING COMBUSTION PRODUCTS AND CONDENSATE TO COLLECT IN THE BUILDING.

MODEL F80A

IMPORTANT: THIS FURNACE IS NOT TO BE VENTED IN THE SAME CHIMNEY OR VENTING SYSTEM SERVING A SOLID FUEL APPLIANCE (WOOD OR COAL). IF THE FURNACE IS TO BE VENTED INTO A CHIMNEY THAT NO LONGER SERVES A FIREPLACE, THE FIREPLACE OPENING IS TO BE PERMANENTLY SEALED.

The furnace must connect to a listed chimney (B-1 Vent), or vent complying with a recognized standard, or a suitably sized, constructed and lined masonry chimney. The chimney lining method and material must comply with local requirements. Use corrosion resistant material meeting nationally recognized standards for vent construction.

Avoid over sizing the furnace for the application. A furnace selected as close as possible for the actual building heat loss will have longer firing cycles which will reduce the potential for damaging condensate formation in the venting system.

Take the building orientation and the presence of other buildings or other nearby structures into consideration when planning the venting system location. Certain external structures could create air turbulence around the vent termination leading to downdrafts and similar venting problems.

If local experience indicates that condensation problems are probable, provide for drainage and disposal of venting system condensate.

VENT SIZING

The venting system, taking all appliances to be vented into consideration, must be sized in accordance with the Venting Tables and rules published in the current editions of ANSI Z223.1 / NFPA 54, National Fuel Gas Code in the United States, or B149, Natural Gas and Propane Installation Code in Canada. An undersized venting system will not permit the complete removal of products of combustion, and an oversized venting system will not heat up quickly enough to avoid condensation formation.

VENT INSTALLATION

Vents and chimneys usually extend vertically with offsets not exceeding 45° from vertical. Consider all offsets greater than 45° from vertical as horizontal runs. Include their length in the total horizontal run calculation.

Horizontal runs should be as short as practical and not exceed 75% of the vent height.

The vent height must be a minimum of 5 feet above the highest appliance in a Category I venting system.

Minimize vent connector horizontal runs to the extent possible for best performance. Avoid unnecessary fittings. For example, an offset constructed of 45° elbows is generally better than one made of 90° elbows.

Support all horizontal sections of the venting system with pipe hangers, strap or equivalent at each joint to prevent sagging. Horizontal segments must slope upward from the furnace to vent or chimney with a minimum 1/4 inch per foot.

When the vent tables from ANSI 223.1/NFPA 54 or B149 permit more than one pipe diameter for the vent or vent connector, the smallest size is usually the best choice to help reduce the potential for condensation formation.

When using manufactured venting (B-1 Vent for example), follow the vent manufacturer's instructions. UL listed B-1 venting both flexible and rigid, are suitable venting materials for the furnace.

The installer must ensure that the venting of the furnace and all other gas appliances connected to the vent or chimney function properly.

INDUCER BLOWER INSTALLATION

This furnace can be installed in upflow, counterflow and horizontal applications. The furnace is capable of being vented vertically through the top panel, left or right through the side panels. Each furnace is assembled and supplied set up for vertical venting applications. If the installer chooses to vent through the side panels such as in horizontal or counterflow applications, rotation of the inducer will be required. In addition, the pressure switch will require relocation in the event of a right hand inducer discharge installation.

INDUCER ROTATION STEPS ON 70-3, 70-4, 85-3, 85-4, 100-3, 100-4, 100-5, 115-5 and 135-5 (See Figure 4A below for Right Exhaust, Figure 4B below for Left exhaust)

1. Ensure all power to the furnace is disconnected.
2. Disconnect inducer wiring and pressure switch tubing.
3. Remove four screws securing inducer plate to flue box cover plate.
4. Place inducer plate and gasket in desired position and locate mounting holes required. **NOTE: INDUCER PLATE AND GASKET MUST BOTH BE ROTATED.**
NOTE: Any holes not concealed by the inducer gasket require the use of screws to plug the holes.
5. Secure inducer plate to flue box cover using four screws in the correct mounting position.
6. Carefully remove side panel knockout corresponding to the venting application and install knockout underneath top panel using two screws (field supplied).
7. In the event of a right hand discharge inducer application, the pressure switch will have to be relocated to the underside of the top panel (see Figure 4A below) using existing holes in top panel. The pressure switch tubing will have to be cut to the length listed in Table 4 on page 10 if inducer is mounted in right hand configuration.
8. Connect inducer wiring and pressure switch tubing to the inducer housing.

FIGURE 4A: RIGHT INDUCER POSITION

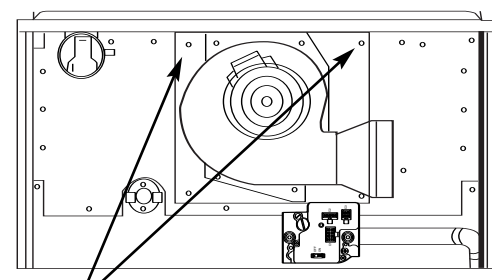

Inducer Plate mounting screws (all models except 35-2, 50-3)

FIGURE 4B: LEFT INDUCER POSITION

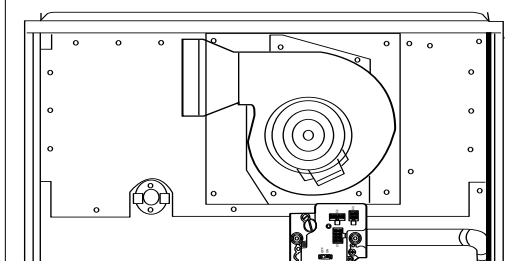

INDUCER ROTATION STEPS ON 35-2, 50-3 (See Figures 5A and 5B below)

1. Ensure all power to the furnace is disconnected.
2. Disconnect inducer wiring and pressure switch tubing.
3. Remove four screws securing inducer and inducer plate to flue box cover plate. (see figure 4A on page 9)
4. Place inducer plate and gasket in desired position and locate mounting holes required. **NOTE: INDUCER PLATE AND GASKET MUST BOTH BE ROTATED.**
NOTE: Any holes not concealed by the inducer gasket require the use of screws to plug the holes.
5. Secure inducer and inducer plate to flue box cover using four screws in the correct mounting position.
6. Carefully remove side panel knockout corresponding to the venting application and install cover (part #30763) underneath top panel using two screws (field supplied). In the event of a right hand discharge inducer application, the pressure switch will have to be relocated to the underside of the top panel. The pressure switch tubing will have to be cut to the length listed in Table 4 (below) if inducer is mounted in right hand configuration.
7. Reconnect inducer wiring and pressure switch tubing to the inducer

FIGURE 5A: LEFT INDUCER POSITION (35-2, 50-3)

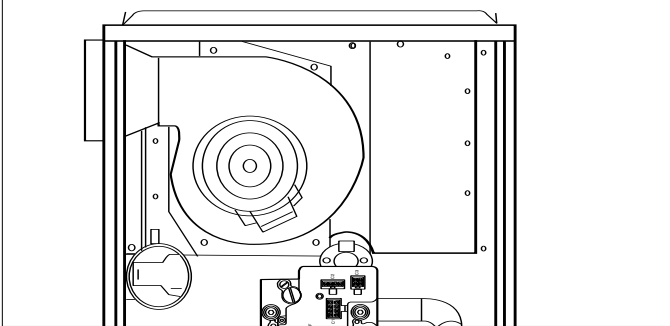

FIGURE 5B: RIGHT INDUCER POSITION (35-2, 50-3)

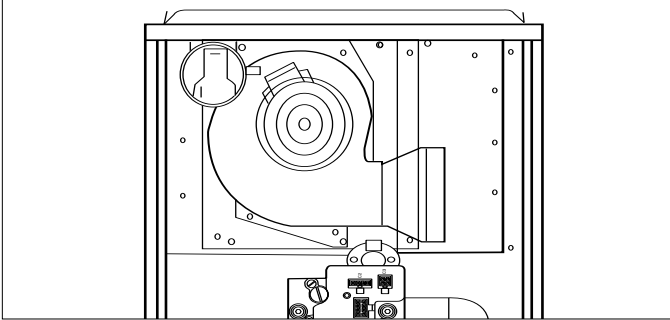

TABLE 4: PRESSURE SWITCH TUBING LENGTH FOR RIGHT INDUCER POSITION (IN INCHES)

35-2	50-3	70-3	70-4	85-3	85-4
12 1/2"	12 1/2"	13 1/2"	13 1/2"	13 1/2"	13 1/2"
100-3	100-4	100-5	115-5	135-5	
13 1/2"	13 1/2"	13 1/2"	13 1/2"	13 1/2"	

VENT CONNECTOR

The furnace may be vented with a listed single wall or Type B double wall vent connector to a B-Vent or lined masonry chimney. Most United States jurisdictions require a minimum 28-gauge galvanized single wall vent connector. Most Canadian jurisdictions require the vent connector to have corrosion resistance equivalent to 24-gauge galvanized sheet metal.

Observe the rules concerning clearance to combustibles.

The vent connector must be readily accessible for inspection, cleaning or replacement.

Keep the vent connector as short as possible by locating the furnace as close as practical to the vent or chimney. Avoid unnecessary turns or bends that create resistance to the flow of the vent gases. Fittings such as elbows add resistance to the vent connector.

Use Type B vent connectors in attics, crawl spaces, or other cold areas. Install thimbles that meet clearance to combustibles requirements and local code requirements if the vent connector must pass through a wall or partition constructed of combustible material. The preferred method to join vent connectors to a vent or chimney is by individual connections. If two vent connectors must be joined before the vent or chimney, use a correctly sized wye or tee-wye fitting as close to the vent or chimney as practical.

All furnace collars are 4 inch. When the United States ANSI Z223.1 / NFPA 54 or Canadian B149 venting tables specify the use of 3 inch venting, use a 4 to 3 reducer at the furnace collar. When the venting tables specify the use of 5inch venting, use a 5 to 4 reducer at the furnace collar.

Secure all single wall vent connector segments together with a minimum of three sheet metal screws per joint. Secure the vent connector to the furnace collar with a minimum of three sheet metal screws. Type B vent connectors do not require sheet metal screws since they have their own locking system.

Direct Vent Terminal Clearances

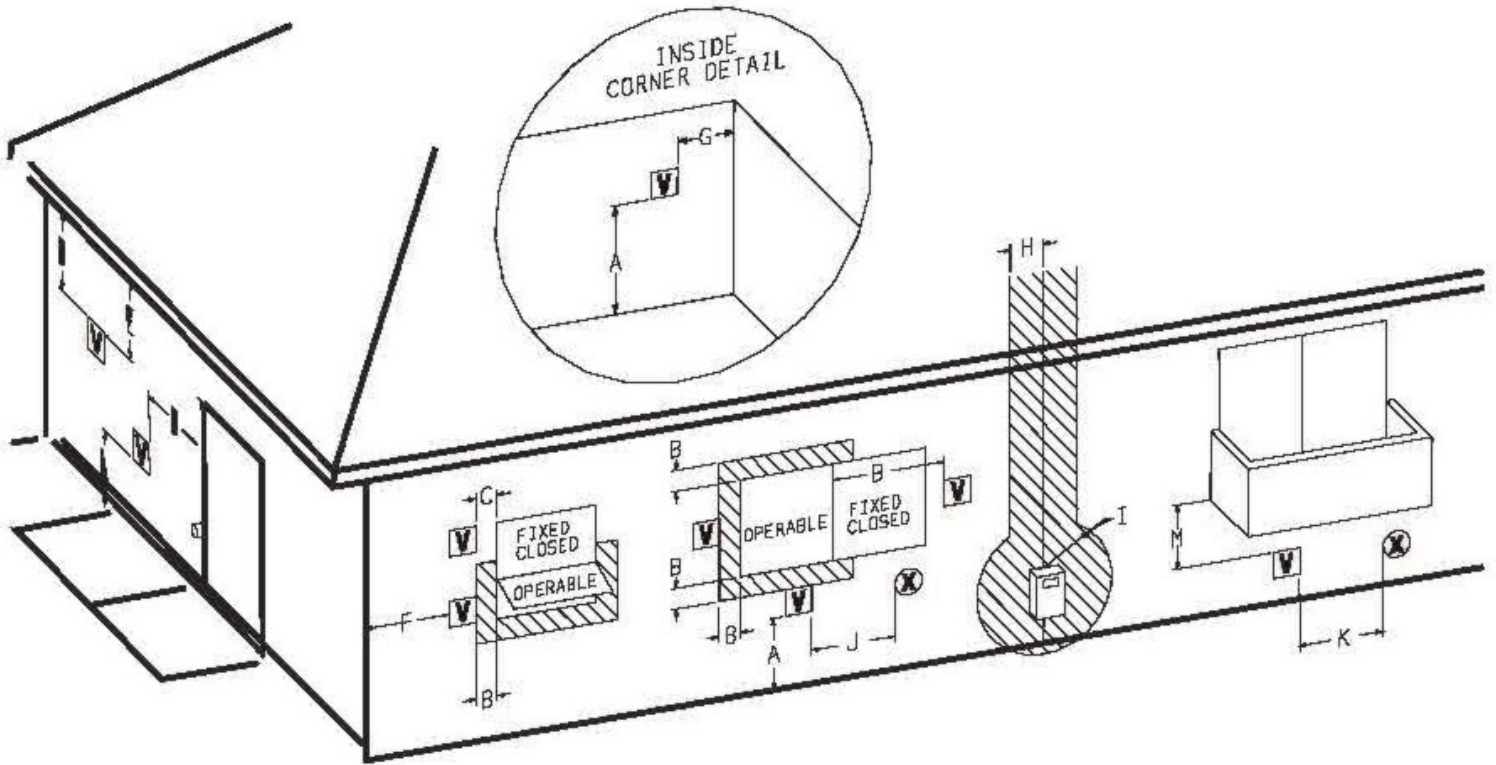

V VENT TERMINAL

X AIR SUPPLY INLET

Hatched Area AREA WHERE TERMINAL IS NOT PERMITTED

	Canadian Installations	US Installations
A = Clearance above grade, veranda, porch, deck, or balcony	12 in (30 cm)	12 in (30cm)
B = Clearance to window or door that may be opened	6 in (15 cm) for appliances 10,000 Btuh (3 kW), 12 in (30 cm) for appliances > 10,000 Btuh (3 kW) and 100,000 Btu (30 kW), 36 in (91 cm) for appliances > 100,000 Btuh (30 kW)	6 in (15 cm) for appliances 10,000 Btuh (3 kW), 9 in (23 cm) for appliances > 10,000 Btuh (3 kW) and 50,000 Btuh (15 kW), 12 in (30 cm) for appliances > 50,000 Btuh (15 kW)
C = Clearance to permanently closed window	*	*
D = Vertical clearance to ventilated soffit located above the terminal within a horizontal distance of 2 ft(61 cm) from the center line of the terminal	*	*
E = Clearance to unventilated soffit	*	*
F = Clearance to outside corner	*	*
G = Clearance to inside corner	*	*
H = Clearance to each side of center line extended above meter/regulator assembly	3 ft (91cm) within a height 15 ft (457 cm) above the meter / regulator assembly	*
I = Clearance to service regulator vent outlet	3 ft (91 cm)	
J = Clearance to nonmechanical air supply inlet to building or the combustion air inlet to any other appliance	6 in (15 cm) for appliances 10,000 Btuh (3 kW), 12 in (30 cm) for appliances > 10,000 Btuh (3 kW) and 100,000 Btuh (30 kW), 36 in (91 cm) for appliances > 100,000 Btuh (30 kW)	6 in (15 cm) for appliances 10,000 Btuh (3 kW), 9 in (23 cm) for appliances > 10,000 Btuh (3 kW) and 50,000 Btuh (15 kW), 12 in (30 cm) for appliances > 50,000 Btuh (15 kW)
K = Clearance to a mechanical air supply inlet	6 ft (183 cm)	3 ft (91 cm) above if within 10 ft (305 cm) horizontally
L = Clearance above paved sidewalk or paved driveway located on public property	7 ft (213 cm) **	*
M = Clearance under veranda, porch deck or balcony	12 in (30 cm) ***	*

* For clearances not specified in ANSI Z223.1/NFPA 54 or CSA B1 49.1, the following statement shall be included: "Clearance in accordance with local installation codes and the requirements of the gas supplier and the manufacturer's installation instructions."

** A vent shall not terminate directly above a sidewalk or paved driveway that is located between two single family dwellings and serves both dwellings

*** Permitted only if veranda, porch ,deck, or balcony is fully open on a minimum of two sides beneath the floor.

VENT TERMINATION

Terminate all vertical vents with a listed vent cap or roof assembly unless local codes require otherwise. Locate the termination in an area free of positive pressure or wind eddies. Eddies may occur when wind swirls over roof peaks. They can cause downdrafts and interfere with normal vent operation.

Some manufactured vent caps are resistant to wind and eddies; their use is recommended.

The vent termination must be a minimum of 5 feet above the highest gas appliance connection. The vent must extend a minimum of 3 feet above the point that it passes through the roof. The vent termination must be a minimum of 2 feet higher than any part of the building horizontally within 10 feet of the vent.

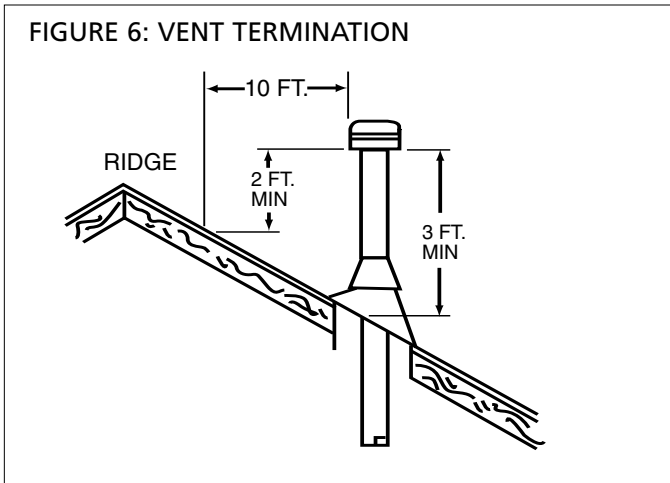

CAUTION

FAILURE TO PROPERLY TERMINATE THE VENT OR CHIMNEY SYSTEMS COULD ALLOW COMBUSTION PRODUCTS TO COLLECT INSIDE THE BUILDING CAUSING PERSONAL INJURY OR DEATH.

DEDICATED VENTING

Figure 7 (below) shows a good method to permit dedicated venting making use of B-Vent within a masonry chimney.

When using this method, provide support for the B-Vent.

IMPORTANT: maintain at least 1-inch clearance between the B-Vent and the chimney tile or chimney. This will help prevent the formation of condensation.

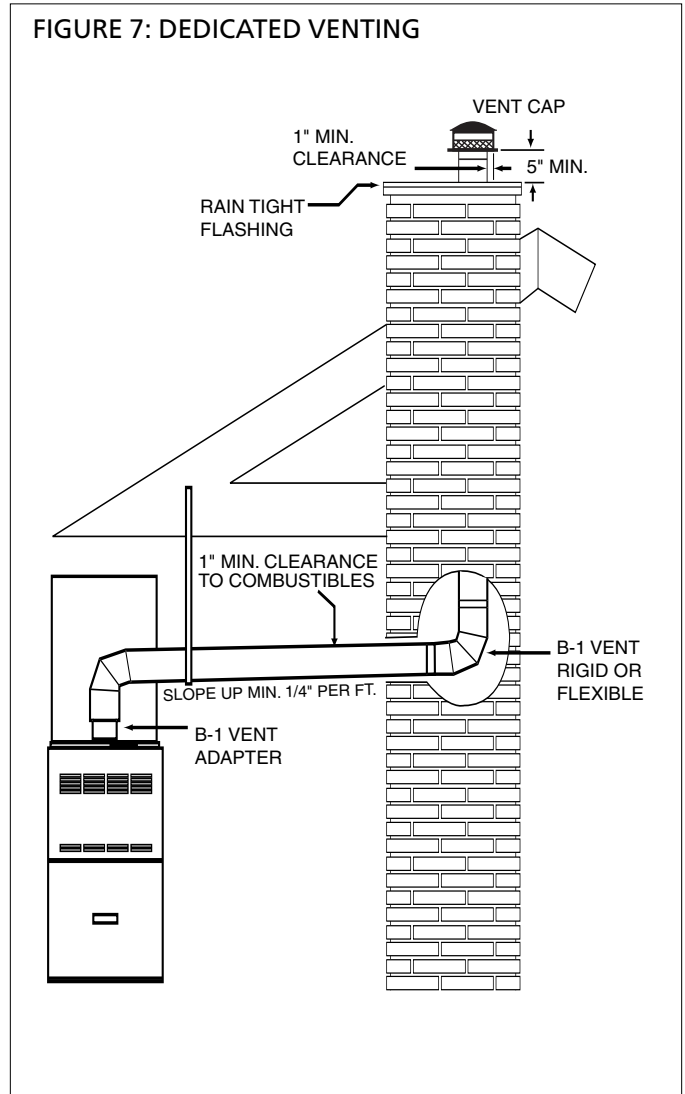

EXISTING VENT CONSIDERATIONS

If this furnace is to replace a Category I type furnace connected to a chimney serving other appliances, steps must be taken to ensure that this furnace and the remaining appliances will vent properly after the removal of the existing furnace. There is a chance that the existing chimney will be too large.

Check the size of the existing vent or chimney. It should be sized as though this is a new installation. If it is not, undertake remedies to correct the size.

Check the condition of the existing vent or chimney. Examine vent or chimney cleanouts to make sure that they remain tightly closed when not in use. Ensure that the vent or chimney passageway is clear and free from obstructions. Look for evidence of condensation damage or deterioration in the vent or chimney. Either of these conditions indicates an inadequate vent. Missing mortar in the top few courses of brick in a masonry chimney is a definite sign of condensation damage.

If the vent or chimney is found to be damaged or inadequate, it must be repaired or replaced. The repaired or replacement vent or chimney must meet the standards prescribed in ANSI Z223.1 National Fuel Gas Code (NEPA 54), in the United States or CAN/CSA-B149, Natural Gas and Propane Installation Code in Canada.

When the new furnace is connected to a common vent, the new furnace and the other appliances connected to the common vent must be tested individually following these steps:

1. Permanently seal any unused openings into the common vent system.
2. Visually inspect the venting system for proper size and horizontal pitch and determine that there is no blockage, restriction, leakage, corrosion, collapsed materials such as fallen bricks, or any other deficiency that could lead to an unsafe condition.
3. Insofar as practical, duplicate winter operating conditions such as closing all windows and doors in the building. If the remaining appliances are in a mechanical room, close the door to the room.
4. Close the fireplace dampers if any.
5. Turn on any appliances that exhaust air to the outdoors on maximum speed. This would include clothes dryers, range hoods, bathroom fans, etc. Attic fans or other fans used only in summer should be exempted from the test.
6. Follow the lighting instructions of the appliance being tested and turn it on to continuous operation.
7. For appliances equipped with draft hoods, test for spillage at the draft hood relief opening after 5 minutes of main burner operation. Detect for spillage using a match flame, taper (candle), or the smoke from a cigarette, cigar or pipe.
8. After it has been proven that each appliance to remain connected to the common venting system properly vents when tested as listed above, return the windows, doors, fireplace dampers, appliances, etc. to the condition they were in prior to the test.
9. If improper venting is observed during any of the tests, the common venting system must be resized. In the United States, refer to the latest ANSI Z223.1 National Fuel Gas Code (NEPA 54), or AGA-GAMA Venting Tables for Category I furnaces. In Canada, refer to the latest addition of CAN/CSA-B149, Natural Gas and Propane Installation Code.

GAS SUPPLY

⚠ WARNING ⚠

THIS FURNACE IS FACTORY EQUIPPED TO BURN NATURAL GAS ONLY.

CONVERSION TO L.P. GAS REQUIRES SPECIAL KIT No. 30482.

FAILURE TO USE THE PROPER CONVERSION KIT CAN CAUSE FIRE, EXPLOSION, CARBON MONOXIDE POISONING, PROPERTY DAMAGE, PERSONAL INJURY OR LOSS OF LIFE.

⚠ CAUTION ⚠

CONVERSION OF THIS FURNACE REQUIRES SPECIALIZED EQUIPMENT. A TRAINED AND QUALIFIED INSTALLER, SERVICE AGENCY OR GAS SUPPLIER MUST COMPLETE CONVERSION.

⚠ CAUTION ⚠

CONNECT THIS FURNACE ONLY TO GAS SUPPLIED BY A COMMERCIAL UTILITY OR SUPPLIER. PRIVATE GAS WELLS DO NOT GENERALLY PROVIDE GAS WITH CONSISTENT, UNIFORM AND PREDICTABLE HEATING VALUES AND DENSITIES. MANY NONCOMMERCIAL WELLS CONTAIN IMPURITIES SUCH AS SULPHUR, WHICH MAY DAMAGE THE FURNACE. THIS FURNACE CANNOT OPERATE PROPERLY OR SAFELY USING FUELS OUTSIDE NORMAL COMMERCIAL STANDARDS.

GAS PIPING

In the United States, the gas piping should be installed in accordance with ANSI Z223.1 / NFPA 54 and any local codes. In Canada, the gas piping should be installed in accordance with CAN/CSA-B149, and in accordance with any local codes.

The gas piping may enter the furnace from either side.

Install a BMI ground joint union between the gas valve and the side panel to allow easy removal of the burner for service purposes.

IMPORTANT: ALWAYS USE A BACKUP WRENCH TO PREVENT TWISTING OF THE CONTROL ASSEMBLY AND GAS VALVE. ANY STRAINS ON THE GAS VALVE CAN AFFECT POSITIONING OF THE ORIFICES RELATIVE TO THE BURNERS. THIS COULD RESULT IN FAULTY BURNER OPERATION.

Install a manual gas shutoff valve and dirt pocket as close to the furnace as possible. Some local codes call for the manual gas shutoff valve to be located between 4 to 5 feet above floor level to prevent tampering by small children. Ensure that the valve is readily accessible.

If local codes allow the use of a flexible gas appliance connector, always use a new listed connector. Do not use a connector which has previously serviced another gas appliance.

⚠ CAUTION ⚠

ENSURE THAT THE MANUAL SHUTOFF VALVE AND GAS VALVE ARE NOT SUBJECTED TO HIGH PRESSURES.
DISCONNECT THE MANUAL SHUTOFF VALVE AND GAS VALVE DURING ANY PRESSURE TESTING THAT EXCEEDS 1/2 P.S.I.G. (3.45 KPA).

The natural gas inlet supply pressure should be 5 to 7 inches water column (w.c.), 7 inches w.c. is recommended.

The L.P. gas inlet supply pressure should be 11 to 13 inches w.c., 12 inches w.c. is recommended.

These pressures must be maintained while all other gas fired appliances are operating at maximum conditions.

Do not exceed 13 inches w.c. inlet pressure with LP. Do not exceed 10.5 inches w.c. inlet pressure with NG.

The gas valve has an adjustable internal regulator for controlling burner manifold pressure. Burner manifold pressure is listed on the furnace rating plate.

LEAK TESTING

All new gas piping installations should be pressure tested as specified by CAN/CGA-B149 or NFPA 54 ANSI Z223.1 or ANSI/NFPA 58, Standard for the Storage and Handling of Liquefied Petroleum Gases.

Gas piping that has not been pressure tested, from the manual shutoff valve to the furnace gas valve for example, should be leak tested using an electronic combustible gas detector, a commercially prepared leak detector such as Gas Leak Detector® or Search®, or other locally approved method. A leak detector solution can be prepared by mixing a small quantity of dish detergent with water and daubing it onto the gas piping and connections.

PURGING GAS LINES

⚠ WARNING ⚠

NEVER PURGE A GAS LINE INTO THE COMBUSTION CHAMBER.

NEVER USE A MATCH, TAPER, CIGARETTE LIGHTER, FLAME OR ANY OTHER IGNITION SOURCE TO CHECK FOR LEAKS IN A GAS LINE.

FAILURE TO ADHERE TO THIS WARNING CAN CAUSE A FIRE OR EXPLOSION RESULTING IN PROPERTY DAMAGE, PERSONAL INJURY, OR LOSS OF LIFE.

CONVERSIONS

HIGH ALTITUDE

In the United States, the modifications for high altitude are based on a 4 percent reduction of input capacity for every 1000 feet above sea level. Table 4 on page 15 illustrates the impact of altitude for selected elevations. Ratings shown apply to the highest elevation in range.

Consult with local fuel suppliers or authorities to determine local regulations or customs.

In Canada, the furnace may be converted for high altitude (2000 - 4500 feet) by changing the burner orifices. Use Kit No. 30552. The kit contains both natural gas and L.P. gas orifices; see Table 5 on page 15. ***Model F80A035 is not approved for LP.**

NATURAL TO L.P. GAS

This series furnace is manufactured as a natural gas (sea level) appliance. It may be converted to L.P. gas with the use of Kit No. 30482 (contact manufacturer for availability). The kit contains the orifices needed for all models, the regulator spring for the gas valve, and a label to affix adjacent to the appliance rating plate to alert subsequent service technicians of the conversion.

L.P. TO NATURAL GAS

Although the furnace is manufactured initially as a natural gas appliance, if after an L.P. Gas conversion it becomes necessary to convert back to natural gas, and if the original parts are unavailable, Kit No. 30551 may be purchased. It is similar in nature and content to the L.P. Gas conversion kit.

CONVERSION STEPS

To convert from sea level to high altitude, from natural gas to L.P. gas, or from L.P. gas to natural gas, follow these steps:

Turn off gas supply to the furnace if applicable.

1. Shut off electrical power to the furnace if applicable.
2. Remove the upper front door to expose the gas train and burner assembly.
3. Unfasten the ground joint union between the gas valve and gas supply piping if applicable.
4. Unfasten the burner manifold pipe from the burner assembly. It is held in place by 2 screws on either end of the manifold pipe.
5. Remove the existing orifices with a 7/16 inch socket, box or openend wrench. Install the replacement orifices. The orifice spuds are brass, and do not normally require pipe dope. A light grease may be used to lubricate the threads. The orifice spuds have tapered threads; do not overtighten them.
If completing a fuel conversion, remove the protective screw cap from the gas valve regulator adjustment. Remove the regulator adjustment screw by turning it counterclockwise. Remove the existing regulator spring.
6. Install the new regulator spring. NOTE: If converting the White-Rodgers gas valve, the regulator spring is tapered. The tapered end (small end) is inserted back into the gas valve regulator adjustment cavity.
Reinstall the adjustment. Give it 3 full clockwise turns initially. Do not reinstall the protective screw cap yet.
7. Reinstall the burner manifold pipe assembly following steps 4, 5, and 6 in reverse order.

If, in all other respects the furnace is ready to be fired, continue with the installation. If not, complete the remainder of the installation then return to these steps before starting the Startup & Setup section.

TABLE 4: HIGH ALTITUDE SPECIFICATIONS - USA

MODEL Input x 1000	ALTITUDE Feet	INPUT BTU/hr	OUTPUT BTU/hr	NAT. ORIFICE	L.P. ORIFICE	QTY.
35	0 - 2000	35,000	28,000	1.95 mm	1.20 mm	2
	2000 - 3000	30,800	24,640	1.83 mm	1.13 mm	
	3000 - 4000	29,400	23,520	1.79 mm	1.10 mm	
	4000 - 5000	28,000	22,400	1.74 mm	1.07 mm	
50	5000 - 6000	26,600	21,280	1.70 mm	1.05 mm	3
	0 - 2000	50,000	40,000	1.95 mm	1.20 mm	
	2000 - 3000	44,000	35,200	1.83 mm	1.13 mm	
	3000 - 4000	42,000	33,600	1.79 mm	1.10 mm	
70	4000 - 5000	40,000	32,000	1.74 mm	1.07 mm	4
	5000 - 6000	38,000	30,400	1.70 mm	1.05 mm	
	0 - 2000	68,000	54,400	1.95 mm	1.20 mm	
	2000 - 3000	59,840	47,872	1.83 mm	1.13 mm	
85	3000 - 4000	57,120	45,696	1.79 mm	1.10 mm	5
	4000 - 5000	54,400	43,520	1.74 mm	1.07 mm	
	5000 - 6000	51,680	41,344	1.70 mm	1.05 mm	
	0 - 2000	85,000	68,000	1.95 mm	1.20 mm	
100	2000 - 3000	74,800	59,840	1.83 mm	1.13 mm	6
	3000 - 4000	71,400	57,120	1.79 mm	1.10 mm	
	4000 - 5000	68,000	54,400	1.74 mm	1.07 mm	
	5000 - 6000	64,600	51,680	1.70 mm	1.05 mm	
115	0 - 2000	100,000	80,000	1.95 mm	1.20 mm	7
	2000 - 3000	88,000	70,400	1.83 mm	1.13 mm	
	3000 - 4000	84,000	67,200	1.79 mm	1.10 mm	
	4000 - 5000	80,000	64,000	1.74 mm	1.07 mm	
135	5000 - 6000	76,000	60,800	1.70 mm	1.05 mm	8
	0 - 2000	115,000	92,000	1.95 mm	1.20 mm	
	2000 - 3000	101,200	80,960	1.83 mm	1.13 mm	
	3000 - 4000	96,600	77,280	1.79 mm	1.10 mm	
150	4000 - 5000	92,000	73,600	1.74 mm	1.07 mm	9
	5000 - 6000	87,400	69,920	1.70 mm	1.05 mm	
	0 - 2000	135,000	108,000	1.95 mm	1.20 mm	
	2000 - 3000	118,800	95,040	1.83 mm	1.13 mm	
175	3000 - 4000	113,400	90,720	1.79 mm	1.10 mm	10
	4000 - 5000	108,000	86,400	1.74 mm	1.07 mm	
	5000 - 6000	102,600	82,080	1.70 mm	1.05 mm	

TABLE 5: HIGH ALTITUDE SPECIFICATIONS - CANADA

MODEL Input x 1000	ALTITUDE Feet	INPUT BTU/hr	OUTPUT BTU/hr	NAT. ORIFICE	L.P. ORIFICE	QTY.
35	0 - 2000	35,000	28,000	1.95 mm	1.20 mm	2
	2000 - 4500	31,500	25,200	1.90 mm	1.15 mm	
50	0 - 2000	50,000	40,000	1.95 mm	1.20 mm	3
	2000 - 4500	45,000	36,000	1.90 mm	1.15 mm	
70	0 - 2000	68,000	54,400	1.95 mm	1.20 mm	4
	2000 - 4500	61,200	48,960	1.90 mm	1.15 mm	
85	0 - 2000	85,000	68,000	1.95 mm	1.20 mm	5
	2000 - 4500	76,500	61,200	1.90 mm	1.15 mm	
100	0 - 2000	100,000	80,000	1.95 mm	1.20 mm	6
	2000 - 4500	90,000	72,000	1.90 mm	1.15 mm	
115	0 - 2000	115,000	92,000	1.95 mm	1.20 mm	7
	2000 - 4500	103,500	82,800	1.90 mm	1.15 mm	
135	0 - 2000	135,000	108,000	1.95 mm	1.20 mm	8
	2000 - 4500	121,500	97,200	1.90 mm	1.15 mm	

TABLE 6: AIRFLOW SPECIFICATIONS

MODEL	FAN HP	SPEED	AIRFLOW - CFM					
			EXTERNAL STATIC PRESSURE - Inches w.c.					
			0.10	0.20	0.30	0.40	0.50	0.60
35-2	10-4 DD 1/4	HIGH	892	900	910	907	899	884
		MED-HI	721	730	751	763	769	757
		MED-LO	589	603	614	625	632	632
		LOW	519	527	539	547	556	551
50-3	10-7 DD 1/3	HIGH	1512	1496	1448	1406	1337	1272
		MED-HI	1322	1311	1288	1249	1208	1140
		MED-LO	980	971	963	954	929	896
		LOW	754	746	738	735	723	690
70-3	10-8 DD 1/3	HIGH	1688	1643	1589	1527	1465	1389
		MED-HI	1415	1401	1386	1356	1306	1250
		MED-LO	988	992	1008	1008	1001	970
		LOW	721	736	763	768	765	765
70-4 <i>2 Side Returns</i>	10-9 DD 1/2	HIGH	1710	1681	1655	1612	1559	1485
		MED-HI	1384	1398	1405	1401	1387	1364
		MED-LO	926	948	975	990	980	964
		LOW	714	728	757	763	760	687
85-3	10-8 DD 1/3	HIGH	1624	1608	1582	1533	1483	1409
		MED-HI	1407	1399	1388	1355	1313	1254
		MED-LO	990	995	999	1005	992	968
		LOW	742	752	766	774	774	769
85-4 <i>2 Side Returns</i>	10-10 DD 1/2	HIGH	2106	2083	2028	1943	1862	1753
		MED-HI	1856	1840	1816	1777	1705	1620
		MED-LO	1577	1587	1600	1580	1530	1465
		LOW	1325	1342	1368	1386	1371	1314
100-4	10-10 DD 1/2	HIGH	1766	1747	1738	1711	1653	1602
		MED-HI	1440	1444	1448	1459	1434	1397
		MED-LO	988	1008	1027	1042	1060	1005
		LOW	768	780	794	747	704	664
100-5 <i>1 Side Return</i>	12-10 DD 3/4	HIGH	2195	2168	2102	2028	1950	1846
		MED-HI	1915	1900	1892	1854	1785	1713
		MED-LO	1610	1621	1621	1594	1612	1550
		LOW	1357	1372	1401	1419	1394	1360
100-5 <i>2 Side Returns</i>	12-10 DD 3/4	HIGH	2399	2359	2290	2219	2146	2070
		MED-HI	2175	2116	2070	2007	1959	1892
		MED-LO	1991	1959	1909	1875	1841	1788
		LOW	1671	1636	1624	1587	1537	1498
115-5 <i>2 Side Returns</i>	12-10 DD 3/4	HIGH	2413	2334	2280	2197	2126	2051
		MED-HI	2253	2197	2111	2051	1990	1911
		MED-LO	2140	2096	2021	1959	1895	1845
		LOW	1820	1789	1735	1679	1644	1597
115-5 <i>Bottom & Side Return</i>	12-10 DD 3/4	HIGH	2100	2082	2054	2012	1954	1910
		MED-HI	1782	1763	1738	1746	1704	1670
		MED-LO	1433	1437	1444	1440	1422	1411
		LOW	1231	1234	1238	1238	1237	1233
135-5 <i>2 Side Returns</i>	12-10 DD 3/4	HIGH	2550	2468	2403	2323	2239	2167
		MED-HI	2309	2239	2182	2108	2047	1984
		MED-LO	2182	2123	2077	2015	1968	1902
		LOW	1833	1800	1779	1723	1653	1618
135-5 <i>Bottom & Side Returns</i>	12 x 10 DD 3/4	HIGH	2135	2128	2094	2060	2019	1955
		MED-HI	1822	1807	1800	1791	1768	1736
		MED-LO	1473	1482	1496	1509	1492	1468
		LOW	1241	1258	1270	1278	1270	1265

SETTING THE MANIFOLD (Outlet) GAS PRESSURE (F92-1003 36G Valve Pressure Check Kit)

1. Shut off the gas upstream of valve and move valve switch to "OFF".
2. Using the 3/32 inch hex wrench that is included in the valve pressure check kit, rotate outlet pressure tap screw one revolution counter-clockwise.
3. Attach the 5/16 inch hose that is included in the valve pressure check kit to the outlet pressure boss of the valve. Hose should overlap boss 3/8 inch.
4. Connect 5/16 inch side of connector that is included in the valve pressure check kit to the hose on outlet boss. Connect 1/4 inch side of connector to manometer hose.
5. Turn on gas supply to valve and move valve switch to the "ON" position.
6. Turn on furnace following manufacturer's instructions.
7. Using a leak detection solution check for leaks at hose connections.

⚠ DANGER ⚠

SHUT OFF GAS AND FIX LEAKS IMMEDIATELY BEFORE PROCEEDING.

8. Read manometer. This reading is the system outlet/supply pressure.
9. Follow manufacturer's instructions to adjust outlet /supply pressure, if necessary.
10. Shut off gas supply upstream of valve and move the valve switch to the "OFF" position.
11. Remove manometer and hose from outlet boss.
12. Turn outlet pressure tap screw clockwise to seal the pressure point using the supplied hex wrench. Tighten to 13 in-lbs. minimum.
13. Turn on gas supply to valve and move valve switch to the "ON" position.
14. Turn on furnace following manufacturer's instructions.
15. Using leak detection solution check for leaks at outlet pressure tap. Shut off gas and fix all leaks immediately before proceeding.

If problems were encountered with obtaining enough pressure on the manifold, first examine the gas piping system to ensure that it is correctly sized. Pipe sizing is specified in ANSI Z223.1 / NFPA 54 in the U.S., or the B148 Natural Gas and Propane Installation Code in Canada.

CHECKING THE SUPPLY (Inlet) GAS PRESSURE (F92-1003 Valve Pressure Check Kit)

Check inlet pressure following steps 1 through 15 above using the inlet/supply pressure tap boss.

⚠ DANGER ⚠

A TRAINED, QUALIFIED TECHNICIAN MUST DO ALL REGULATOR ADJUSTMENTS. IMPROPER MODIFICATIONS OR ADJUSTMENTS CAN RESULT IN FIRE OR EXPLOSION CAUSING PROPERTY DAMAGE, SEVERE PERSONAL INJURY OR LOSS OF LIFE.

In some circumstances, high inlet pressure can be remedied with the use of an inline appliance regulator. If an inline appliance regulator is used, ensure that it has the capacity to adequately handle the gas volume required by the furnace and any other appliances receiving gas from the header serving the furnace.

Figure 8: White-Rodgers Gas valve

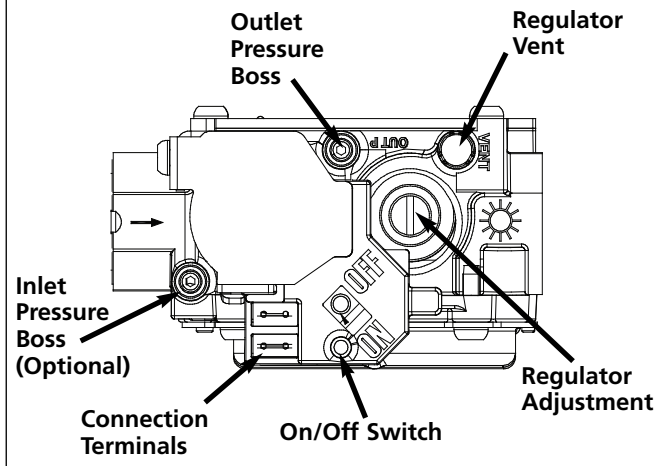

ELECTRICAL SPECIFICATIONS

Before proceeding with the electrical connections, ensure that the available electrical supply is compatible with the voltage, frequency, and phase listed on the appliance rating plate.

All furnaces are rated 120 VAC, 60 Hz, 1 phase. The amperage rating is indicated on the furnace rating plate.

Each furnace requires a dedicated overcurrent device either a circuit breaker or a Type D, time delay fuse. It is permissible to connect furnace accessories such as humidifier transformers, condensate pumps and electronic air cleaners. If adding accessory equipment to the furnace circuit, ensure that the combined amperages listed on the appliance rating plates do not exceed the rating of the over current device.

⚠ DANGER ⚠

SHUT OFF ELECTRICAL POWER AT THE FUSE BOX OR SERVICE PANEL BEFORE MAKING ANY ELECTRICAL CONNECTIONS. FAILURE TO DO SO CAN CAUSE ELECTRICAL SHOCK RESULTING IN PERSONAL INJURY OR LOSS OF LIFE.

⚠ DANGER ⚠

THE FURNACE CABINET MUST HAVE AN UNINTERRUPTED GROUND.

A GROUND WIRE IS PROVIDED IN THE ELECTRICAL JUNCTION BOX.

DO NOT USE GAS PIPING AS A GROUND.

FAILING TO GROUND THE FURNACE PROPERLY CAN RESULT IN ELECTRIC SHOCK RESULTING IN PERSONAL INJURY OR DEATH.

In the United States, all electrical work must be in accordance with the latest edition of the National Electrical Code, ANSI / NFPA 70, in Canada, all electrical work must be in accordance with the latest edition of CSA-C22.1, Canadian Electrical Code Part 1, and any applicable local code.

Although a suitably located circuit breaker may serve as a service switch, a separate service switch is recommended.

A separate in service switch is necessary if the circuit breaker is in a location where accessing it would require getting close to the furnace, or if the furnace is located between the main electrical panel and the entry to the furnace room. The furnace switch (service switch) should be clearly labeled and installed in a location where it is not likely to be mistaken as being a light switch or similar control.

FURNACE CONNECTION

120V: The furnace is shipped fully wired except for the connections to the house wiring. The furnace power connections are made in a junction box inside the blower compartment. The junction box is factory installed on the left hand side however, it may be moved to the right hand side. The junction box contains a BLACK wire to be connected with L1 (hot), a WHITE wire to be connected with L2, the Neutral, and a GREEN wire to be connected to the ground.

Use good quality wire nuts; e.g. Marrette® connectors, Ideal® wire nuts, etc.

IMPORTANT: USE COPPER CONDUCTORS ONLY

If the junction box must be moved to the right hand side:

1. Unfasten the junction box from the left hand side.
2. Remove the right side panel knockout.
3. Remove the junction box cover hook screw and reinstall it on the opposite side of the box.
4. Fasten the junction box to the right hand panel.

NOTE: L1 (hot) and L2 (Neutral) polarity must be observed when making field connections to the furnace. The ignition control may not sense flame if L1 and L2 are reversed. The ground is also essential.

NOTE: The furnace shall be installed so the electrical components are protected from water.

⚠ WARNING ⚠

THIS FURNACE IS EQUIPPED WITH A BLOWER DOOR SAFETY SWITCH. DO NOT DISABLE THIS SWITCH. FAILURE TO FOLLOW THIS WARNING CAN RESULT IN ELECTRICAL SHOCK, PERSONAL INJURY, OR LOSS OF LIFE.

⚠ CAUTION ⚠

ELECTRICAL WIRING AND COMPONENTS MUST BE PROTECTED FROM MOISTURE, INCLUDING WATER AND CONDENSATE.

LOW VOLTAGE WIRING

The low voltage terminals are located on the control board mounted to the blower assembly; see Figure 11 on page 20.

The furnace is prewired for air conditioning. Insert the thermostat and air conditioner contactor low voltage wiring through the bushing provided in the side panel. Route the control wiring through the blower compartment to the 24 volt terminal screws.

THERMOSTAT

The room thermostat must be compatible with the integrated control in the furnace. Electromechanical thermostats should be rated 30 V / 1.5 amps.

Most electronic or microprocessor based thermostats except those with "current robbing" circuits should work satisfactorily. Consult the instructions of the thermostat manufacturer for technical and installation details.

Most compatibility problems can be overcome by the use of an isolation relay. The isolation relay should be SPST with a 24-volt coil. The switch ratings should be a minimum of 0.5 amps; see figure 9 below.

The thermostat and control wiring should be a minimum of 18 AWG copper. Excessive lengths of wire may result in enough voltage drop to impair the proper functioning of the furnace. For thermostat wires in excess of 25 feet, use 16 AWG; 50 feet, use 14 AWG.

Figure 9: Isolation relay

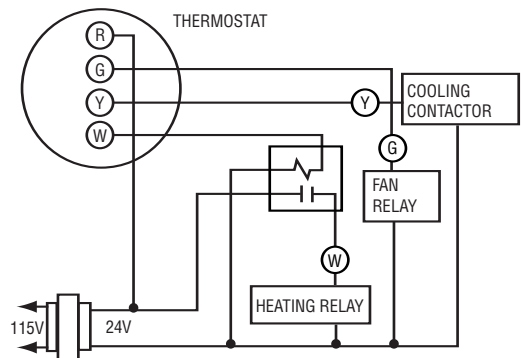

THERMOSTAT LOCATION

The thermostat should be located approximately 5 feet above the floor, on an inside wall where there is good natural air circulation, and where the thermostat will be exposed to average room temperatures. Avoid locations where the thermostat will be exposed to cold drafts, heat from nearby lamps or appliances, exposure to sunlight, heat from inside wall stacks, etc.

THERMOSTAT HEAT ANTICIPATOR SETTING:
0.45 AMP (White-Rodgers)

See page 22 for information on connecting optional accessories such as electronic air cleaners and power humidifiers.

START UP PROCEDURES

This furnace is equipped with a hot surface ignition (HSI) device. Each time that the room thermostat calls for heat, the HSI lights the main burners directly. See the lighting instructions on the furnace.

TO START THE FURNACE:

1. Remove the burner compartment access door.
2. Shut off the electrical power to the furnace and set the room thermostat to its lowest setting.
3. Ensure that the ignition system control switch on the White-Rodgers 36G22 gas valve is in the "ON" position.
4. Replace the burner compartment access door.
5. Restore electrical power to the furnace.
6. Set the room thermostat to a point above room temperature to light the furnace.
7. After the burners are lit, set the room thermostat to the desired temperature.

TO SHUT DOWN THE FURNACE:

1. Set the room thermostat to its lowest setting.
2. Remove the burner compartment access door.
3. The ignition system control switch on the White-Rodgers 36G22 gas valve may be switched to the "OFF" position.
4. The furnace appliance shutoff valve may be closed if desired.

⚠ WARNING ⚠

SHOULD OVER HEATING OCCUR, OR THE GAS BURNERS FAIL TO SHUT OFF, CLOSE THE MANUAL GAS VALVE FOR THE FURNACE BEFORE SHUTTING OFF THE ELECTRICAL POWER TO THE FURNACE. FAILURE TO DO SO CAN CAUSE AN EXPLOSION OR FIRE RESULTING IN PROPERTY DAMAGE, PERSONAL INJURY OR LOSS OF LIFE.

SEQUENCE OF OPERATION

White-Rodgers 36G22 Gas Valve &

White-Rodgers 50A55-250 Integrated Furnace Control

1. Room temperature drops causing the room thermostat heating contacts to close.
2. The induced blower begins a prepurge cycle of 15 seconds.
3. The pressure switch contacts close.
4. After the prepurge period, the hot surface igniter heats up; 10 seconds on a first try, maximum 14 seconds on a subsequent retry.
5. The gas valve opens for a 7 second trial for ignition. The gas burners light, the igniter shuts off. (See next section for sequence of operation in the event of a flame failure).
6. The circulating fan begins 30 seconds after flame is sensed.
7. Furnace continues to run in this state until the room thermostat heating contacts open in response to raised room temperature.
8. With the thermostat heating contacts open, the burner flames extinguish immediately, the induced blower stops after a 5 second postpurge period. The pressure switch contacts open.
9. The circulating fan continues to run until timed out in 60 to 180 seconds, depending on the 50A55-250 Dip Switch settings.

Sequence if the furnace does not light up or detect flame:

1. See steps 1 through 5 for initial operation.
2. If pressure switch contacts are closed; and have failed to open since the last cycle, all subsequent steps will fail to occur.
3. If the burners fail to light, or if the flame is not sensed, the gas valve closes, and, providing that there have been less than 5 trials for ignition, sequence returns to sequence of operation Step 4. If this was the 5th trial for ignition, the ignition system goes into a 60 minute lockout condition, and then reattempts the sequence at Step 4.

In addition, if during the burner firing, the flame signal is lost, the gas valve will close and the ignition sequence will begin again at Step 4 above. If the flame sensing signal is lost more than 5 times during a furnace cycle, the gas valve will close, and the ignition sequence goes into a 5 second postpurge; the induced blower stops. The ignition system goes into a 60 minute lockout condition then reattempts the sequence at Step 4 above.

The 60 minute lockout sequence will repeat itself indefinitely. Lowering the room thermostat setting below room temperature for approximately 10 seconds, or shutting off the electrical supply to the furnace for approximately 10 seconds may interrupt the 60 minute lockout.

4. Furnace continues to run in this state until the room thermostat heating contacts open in response to raised room temperature.
5. With the thermostat heating contacts open, the burner flames extinguish immediately, the induced blower stops after a 5 second postpurge period. Pressure switch contacts open.
6. The circulating fan continues to run until timed out in 60 to 180 seconds, depending on the 50A55-250 Integrated Furnace Control dipswitch settings.

Additional information is available in the Troubleshooting section that starts on page 23 of this manual.

CHECKING FURNACE INPUT

- The natural gas supply pressure should be a maximum of 7 inches w.c. and minimum of 5 inches w.c.
- The burner manifold pressure is normally set to 3.5 inches w.c. for natural gas
- The input rating of the furnace is based on 1075 / BTU/cu. ft. gas with a specific gravity of 0.60

Since heating values for the gas vary geographically, the actual furnace input and output will vary accordingly.

For example, natural gas with a 1000 BTU / cu. ft. heating value will reduce the input to 93% of the rated input. Natural gas with a 1100 BTU / cu. ft. heating value will increase the input to approximately 103% of the rated input. This is not usually a problem; however, adjustments to compensate for this can be made by minor adjustments to the burner manifold pressure or by changing the burner orifice size.

In the previous example where the heating value of the gas is 1100 BTU / cu. ft., the burner manifold pressure can be reduced .3% to 3.4% w.c. which is within the ±0.30 inches w.c. specification to bring the input into compliance. Refer also to Setting the Gas Pressure, and contact the fuel supplier for specific gas heating content values.

If using a gas meter to check the furnace input, be sure that all gas fired appliances other than the furnace are off during the test.

Any adjustments to the burner manifold pressure should be carried out with the use of a manometer or calibrated magnehelic gauge. Do not adjust the gas valve pressure regulator more than ± 0.30 inches water column.

The formula for determining the furnace input via the gas meter test dial is:

$$\text{Input} = \frac{\text{Heating Value of Gas} \times 3600}{\text{Time in Sec. for 1 cu. ft}}$$

Where:

Input is expressed in BTU / Hr.

Heating value of the gas is expressed in BTU / cubic feet

Time means time required for the test dial to indicate 1 cubic foot in seconds.

If using a gas meter with SI (metric) units:

1 cubic foot = 0.0283 cubic meters.

1 cubic meter = 35.315 cubic foot.

0.01cubic meter = 0.3531 cubic foot.

0.5 cubic meter = 1.766 cubic feet.

IMPORTANT: NEVER ADJUST THE INPUT OF THE FURNACE TO EXCEED THE INPUT SHOWN ON THE RATING PLATE.

TEMPERATURE RISE CHECK

When the duct system is complete and the air filter or filters are in place, determine if the airflow is correct.

1. Insert a duct thermometer in the supply air duct. The thermometer should be placed as close as practical to the furnace, but out of the "line of sight" of the heat exchanger (this prevents false readings owing to radiant heat). Ensure that the thermometer location is within the duct air stream. Avoid locations such as the inside radius of an elbow, etc.
2. Insert a duct thermometer in the return air duct as close to the furnace as practical. Ensure that the thermometer location will be unaffected by humidifier bypass ducts, etc. Choose a location well within the main air stream.
3. Operate the furnace long enough to obtain steady state conditions.
4. When the two thermometers have stabilized, usually within 5 - 8 minutes, compare the two readings. Subtract the return air temperature from the supply air temperature. The difference is the temperature rise, also called ΔT .
5. Compare the measured ΔT to the temperature rise range shown on the rating plate.

Unless stated differently on the rating plate, the temperature rise should normally range between 30° to 60°F or 35° to 65°F. When adjusting the temperature rise, the ideal temperature is approximately mid-range.

If the measured ΔT is above the approved temperature range, there is too little airflow. The airflow must be increased by selecting a faster fan speed, removing restrictions in the ductwork, or adding supply or return ductwork.

If the measured ΔT is too low, there is too much airflow. Use a lower speed tap on the multispeed motor. The blower speed is changed at the integrated furnace control. Remove the wire from the "HEAT-H" terminal of the 50A55-20 integrated furnace control and plug in the desired wire on the "HEAT-H" terminal. When this configuration is used, the following color codes are used: Black - High Speed, Blue - Medium-High Speed, Yellow - Medium-Low Speed and Red - Low Speed. The unused leads are connected to the M1, M2 terminals on the 50A55-20 integrated furnace control.

IMPORTANT: If the heating speed and cooling speed are to be the same, remove the cooling lead from the control, tape it off, then install a "piggyback" connector from the control "HEAT" terminal to the "COOL" terminal. **UNDER NO CIRCUMSTANCE MAY TWO MOTOR WINDINGS BE POWERED SIMULTANEOUSLY.**

The piggyback connector is used for both types of motor wiring configuration wiring block and permanent lead, see figure 10 below.

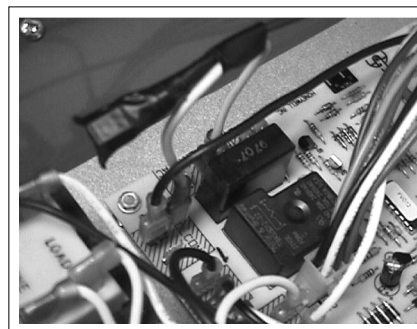

Figure 10:
Piggyback
Connector

Remove blue wire from HEAT terminal, tape it off, and replace it with a jumper. Connect the black wire and jumper to COOL.

AIRFLOW

For proper furnace operation, airflow over the heat exchanger is of utmost importance. Insufficient airflow accelerates metal fatigue and failure in the heat exchanger and excessive airflow promotes accelerated corrosion of the heat exchanger. **IMPORTANT:** Do not bypass this step of the start up procedures.

CALCULATING AIRFLOW

There are circumstances where it may be desirable to know the airflow delivery through the duct system, such as when estimating the amount of airflow available for air conditioning. This can be done by direct measurement with electronic or sloped manometers and velometers, or by using the formula below.

$$Cfm = \frac{\text{Bonnet Output}}{1.085 \leftrightarrow \Delta T}$$

Where:

Cfm is airflow in cubic feet per minute

ΔT is the temperature rise

Bonnet output is the furnace output capacity from the rating plate.

NOTE: The bonnet output will vary directly with the input. If the actual input is below the stated input, the output will be reduced in the same ratio.

ADJUSTING BLOWER SPEEDS

If the blower speeds require adjusting, follow these steps:

⚠ WARNING ⚠

DISCONNECT THE ELECTRICAL SUPPLY TO THE FURNACE BEFORE ATTEMPTING TO CHANGE THE BLOWER SPEED. FAILURE TO DO SO COULD RESULT IN ELECTRICAL SHOCK RESULTING IN PERSONAL INJURY OR LOSS OF LIFE.

1. Remove the blower compartment door.
2. Access the motor electrical wiring.
The blower speed is changed at the integrated furnace control. Remove the wire from the "HEAT" terminal of the 50A55-250 integrated furnace control and plug in the desired wire on the "HEAT" terminal. When this configuration is used, the following color codes are used: Black - High Speed, Blue - Medium-High Speed, Yellow - Medium-Low Speed, and Red - Low Speed. The unused leads are connected to the "PARK" terminals on the 50A55-250 integrated furnace control.
IMPORTANT: If the heating speed and cooling speed are to be the same, remove the cooling lead from the control, tape it off, then install a "piggyback" connector from the control "HEAT" terminal to the "COOL" terminal. **UNDER NO CIRCUMSTANCE MAY TWO MOTOR WINDINGS BE POWERED SIMULTANEOUSLY.**
3. Slide the blower assembly back into position, and refasten with the sheet metal screws.
4. Reinstall the blower compartment door.
5. Recheck temperature rise.

NOTE: Temperature rise should always be rechecked whenever blower speed changes are done.

SETTING BLOWER "OFF" TIMINGS

Both control systems allow flexibility in the FAN OFF delay function. The control is located in the blower compartment. Follow the same steps as listed in Adjusting Blower Speeds to access the control.

DIP SWITCH		
HEAT "OFF" DELAY		
SW 1	SW-2	SEC.
ON	ON	60
OFF	ON	90
ON	OFF	120*
OFF	OFF	180

Figure 11: 50A55-250 Dip Switch Settings

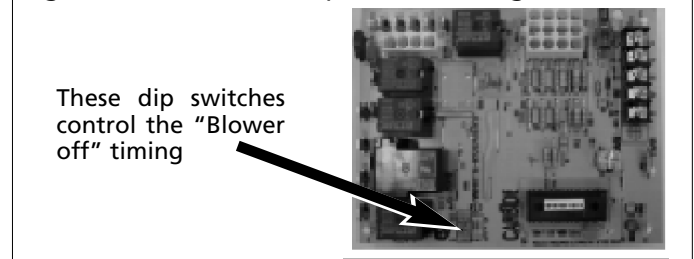

HOW TO REMOVE THE BLOWER

1. Disconnect power from furnace.
2. Remove thermostat wiring from the integrated furnace control.
3. Remove L1, Neutral and Ground connections between the integrated furnace control and the Furnace electrical connection junction box.
4. Remove 12 pin male moxex connector from female connection point, and ground connection from integrated furnace control.
5. Unscrew 2 blower housing bolts located in the front blower shroud as indicated in figure 12 below. Remove front blower shroud from furnace.
6. Slide blower assembly towards front of furnace. Blower is mounted on rail system, and will slide forward about 10 inches before blower is clear of rails.

HOW TO INSTALL THE BLOWER

1. Place blower into blower compartment.
2. Keep blower assembly tight to top of blower compartment. Line up blower assembly to slide into blower rails. Push blower assembly towards back of furnace ensuring blower assembly is correctly placed in blower rails. Insert blower shroud on the front of the blower housing. Insert blower housing bolts and tighten.
3. Connect thermostat wiring to the integrated furnace control.
4. Connect L1, Neutral and Ground connections between the integrated furnace control and the furnace electrical connection junction box.
5. Connect 12 pin male moxex connector to female connection point, and ground connection to the integrated furnace control.
6. Turn on power to the furnace.

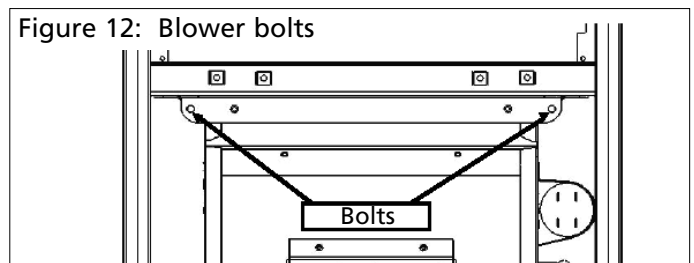

Figure 12: Blower bolts

MAINTENANCE

⚠ WARNING ⚠

DISCONNECT THE ELECTRICAL POWER SUPPLY TO THE FURNACE BEFORE ATTEMPTING ANY MAINTENANCE. FAILURE TO DO SO CAN CAUSE ELECTRICAL SHOCK RESULTING IN PERSONAL INJURY OR LOSS OF LIFE.

AIR FILTER

The filter should be inspected frequently and cleaned as necessary. We recommend a monthly inspection at first, perhaps coinciding with the arrival of the monthly fuel bill as a reminder. The frequency may be increased or decreased depending on experience and conditions.

⚠ CAUTION ⚠

Do not operate the furnace without an air filter.

LUBRICATION

Both the induced draft blower motor and circulating fan motor are ball bearing type motors. Neither requires routine lubrication.

IMPORTANT: The motor bearings were prelubricated by the motor manufacturer. Do not attempt to lubricate them. Excess lubrication will void the warranty, shorten the service life of the motors, and will attract the buildup of dust and dirt.

The induced blower motor and circulating fan motor must be cleaned on a periodic basis by a qualified service technician. Dust buildup in the ventilation ports of the motor will cause the motor to not dissipate heat properly resulting in reduced service life.

VENT CONNECTOR

The exhaust venting between the furnace vent box and chimney should be inspected periodically for sags, pitting, evidence of leakage etc. If any of these conditions exist, contact your installation contractor, service agency or fuel supplier.

⚠ WARNING ⚠

HOLES IN THE EXHAUST PIPING OR FURNACE HEAT EXCHANGER CAN ALLOW TOXIC FUMES TO ENTER THE HOME AND CIRCULATE THROUGH THE DUCT SYSTEM RESULTING IN CARBON MONOXIDE POISONING OR DEATH. IF LEAKS ARE FOUND IN THE FURNACE HEAT EXCHANGER, IT MUST BE REPLACED.

OPERATING TIPS

1. Clean air filters maximize efficiency and reduce heating costs.
2. During the heating season, keep windows and doors closed to reduce the heating load on the system.
3. Avoid excessive use of kitchen exhaust hoods and other exhaust fans to reduce the heating load on the system.
4. Arrange the furniture and drapes so that the supply air registers and return air grilles are unobstructed.
5. If you have a perimeter duct system, ideally, the warm air should bathe the cold exterior walls. Avoid the use of plastic deflectors on the supply air registers that tend to short circuit the warm air straight into the return air grilles. These deflectors are often the cause of cool draughts across the floor.
6. Avoid placing heat producing appliances such as televisions, radios, lamps, etc. in a location to influence the thermostat.
7. Keep combustible articles at least 3 feet away from the furnace. Do not block access for servicing the furnace. Do not use the vent connector as a hanger for clothes or anything else.
8. Never attempt to operate the furnace without the blower door in place.

ANNUAL INSPECTION / SERVICE

A qualified installation contractor, service agency or fuel supplier must inspect the furnace annually.

Your annual inspection will normally cover the following:

HEAT EXCHANGER

The heat exchanger should be inspected for corrosion. The flue passages (heat exchanger tubes) should be free of scale or excessive corrosion. Observe the burner flames. If there appears to be flame distortion, check venting for blockage. Also check for signs of inadequate combustion air supply. If flame distortion continues after eliminating the blockage in the venting as the cause, it may be necessary to replace the tubular heat exchanger. The tubular heat exchanger cannot be field cleaned. If the tubular heat exchanger is blocked by soot or excess scale, replace it. Check NOX baffles (installed in heat exchanger tubes) for any distortion. If distorted, replace NOX baffles.

BURNERS

The burners should be inspected to ensure that they are free of deterioration, dust and debris, and properly aligned with the heat exchanger. In most cases, a simple vacuuming with a brush attachment will adequately clean the burner assembly and burner compartment.

⚠ CAUTION ⚠

Be careful when working on the burner assembly. The hot surface igniter is fragile and can break easily.

The flame sensor should be inspected and cleaned with fine steel wool or Scotch-Brite™ scrubbing pad. The wiring connection should be checked to ensure that it is tight and corrosion free.

NOTE: This is a critical connection. Small amounts of corrosion can significantly increase the internal resistance of the connection. A relatively small increase in resistance can result in a large decrease in flame signal.

MODEL F80A

INDUCED BLOWER

The induced blower motor should be inspected and cleaned if necessary. Clear any dust buildup from the ventilation ports.

CIRCULATING FAN

The condition of the circulating fan should be checked to ensure that it is free of excessive dust buildup, debris, etc. The mechanical fasteners should be inspected and checked for proper tightness and parts alignment. The motor ventilation ports should be cleaned if necessary to prevent restriction to cooling by air over the motor.

ELECTRICAL

⚠ WARNING ⚠

DISCONNECT THE ELECTRICAL POWER SUPPLY TO THE FURNACE BEFORE ATTEMPTING THIS MAINTENANCE PROCEDURE. FAILURE TO DO SO CAN CAUSE ELECTRICAL SHOCK RESULTING IN PERSONAL INJURY OR LOSS OF LIFE.

All electrical connections should be examined to ensure that they are tight and corrosion free. Repair any connections that have become loose or corroded.

⚠ CAUTION ⚠

Label all wires prior to disconnection when servicing controls. Wiring errors can cause improper and dangerous operation.

Always verify proper operation after servicing.

FURNACE OPERATION

The furnace should be cycled during the annual inspection and servicing to:

1. Test all safety related controls.
2. Determine that the temperature rise falls within the range shown on the appliance rating plate.
3. Ensure that the burner ignition is smooth and that the flames are smooth soft blue, and not impinging on the heat exchanger.

ACCESSORIES

FIELD SUPPLIED AND INSTALLED OPTIONAL ACCESSORIES

ELECTRONIC AIR CLEANER

The White-Rodgers integrated furnace control has provisions to supply power and control an electronic air cleaner rated at 120vac, 1.0 amp max.

50A55-250: Line voltage for an electronic air cleaner may be picked up from the "EAC-N". 120 volt power will be available at these terminals whenever the circulating fan is operating in the heating or cooling modes.

HUMIDIFIER/ ELECTRONIC AIR CLEANERS

The White-Rodgers integrated furnace control has provisions to supply power and to control a line voltage humidifier or the primary of a 120 / 24 volt humidifier step down transformer, rated at 120vac, 1.0 amp max.

50A55-250: Line voltage for a humidifier may be picked up from the "HUM-H" terminal and from the "HUM-N" terminal. 120 volt power will be available at these terminals whenever the circulating fan is operating in the heating mode.

NOTE: All HUM (humidifier) and EAC (electronic air cleaner) terminals are 120v. Do not directly connect 24v equipment to them.

NOTE: All furnace and furnace accessory wiring shall conform to the temperature limitations of 63°F (35°C) rise.

TROUBLESHOOTING

SEQUENCE OF OPERATION: WHITE RODGERS INTEGRATED FURNACE CONTROL WITH WHITE RODGERS 36G22 GAS VALVE

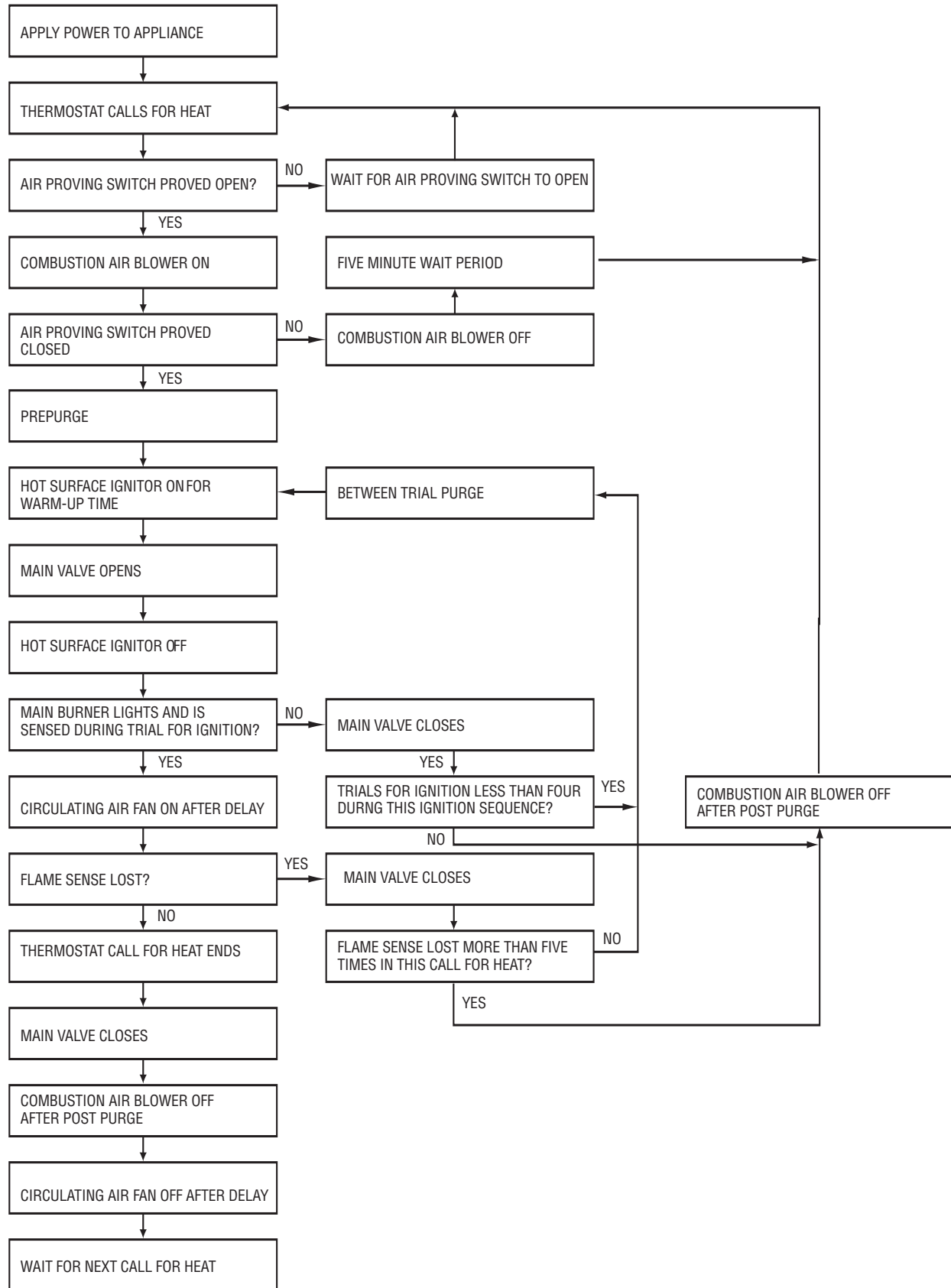

TABLE 10: TROUBLESHOOTING WHITE-RODGERS INTEGRATED FAN CONTROL

LED STATUS	INDICATES	CHECK or REPAIR
FLASH ONCE	The LED will flash once at power up. Normal Operation.	Not applicable
CONTINUOUS ON	Internal Control Failure	Replace Integrated Furnace Control
1 Flash	System Lockout (retries or recycles exceeded)	<ol style="list-style-type: none"> 1. Gas supply off or at too low pressure to operate appliance. 2. Damaged or broken HSI element. 3. Appliance not properly earth grounded.
2 Flashes	Airflow proving switch remains closed. Induced blower will not operate until airflow proving switch opened.	<ol style="list-style-type: none"> 1. Airflow proving switch stuck closed. 2. Airflow proving switch miswired or jumpered.
3 Flashes	Airflow proving switch remains open. Induced blower operates until airflow proving switch closes.	<ol style="list-style-type: none"> 1. Airflow proving switch stuck open. 2. Airflow proving switch operation, tubing, and wiring. 3. Obstructions or restrictions in appliance air intake or exhaust flue system that prevent proper combustion air flow.
4 Flashes	Open high limit switch. Combustion air blower is energized. If control system includes 50V51-250 furnace control, then the heat speed circulating air fan will be energized until the limit string resets.	<ol style="list-style-type: none"> 1. Open high limit switch. 2. Limit switch wiring in good condition and securely connected.
5 Flashes	Open rollout switch or rollout sensed. Combustion air blower is energized. If control system includes 50A55-250 furnace control, then the heat speed circulating air fan will be energized after the selected heat fan on delay.	<ol style="list-style-type: none"> 1. Open rollout switch. 2. Rollout switch wiring in good condition and securely connected.
6 Flashes	115 Volt AC power reversed/improper ground. After 1 hour lockout reset delay, control will reset and initiate a new ignition sequence if the call for heat is still present.	Line voltage polarity correct, and properly earth grounded.
7 Flashes	Low flame sense signal	<ol style="list-style-type: none"> 1. Flame at burner. 2. Dirty or cracked flame sensor
Continuous Flash	Flame sensed with gas valve de-energized.	<ol style="list-style-type: none"> 1. Miswiring is probable cause.

TABLE 11: GENERAL TROUBLESHOOTING WHITE-RODGERS INTEGRATED FAN CONTROL

IF	AND	CHECK or REPAIR
Induced blower does not energize	2 Flash code does not come on	<ol style="list-style-type: none"> 1. Induced blower wiring. 2. Induced blower.
Induced blower does not energize	2 Flash code does come on	<ol style="list-style-type: none"> 1. Pressure switch stuck closed. 2. Pressure switch is mis-wired or jumpered.
Induced blower is energized	3 Flash code does not come on	Wait for the pre-purge to expire.
3 Flash code comes on	Induced blower turns off	<ol style="list-style-type: none"> 1. Pressure switch stuck in the open position. 2. Pressure switch, tubing and wiring. 3. Obstruction in furnace venting that is preventing proper combustion airflow.
Pre-purge time has expired	HSI element does not glow red within 10 seconds.	<ol style="list-style-type: none"> 1. Broken or damaged HSI element. 2. Broken or damaged HSI element leadwires.
HSI element is glowing red.	No other visible control system action	Wait for HSI element warm up time to expire.
HSI element warm up time has expired and main valve has been energized.	Main valve does not light within trial for ignition period	<ol style="list-style-type: none"> 1. Induced blower moving main burner gas away from the HSI element. 2. Inlet gas pressure too low for main burner ignition. 3. Input line voltage too low to heat HSI element. 4. HSI element incorrectly positioned. 5. Clogged or incorrect main burner orifice.
Main burner lights within trial for ignition period.	Main valve is de-energized at the end of the trial for ignition period. If main flame is not sensed during trial for ignition, system will shut off HSI element and main gas flow, then go through another purge period and initiate another ignition trial. A total of 4 ignition trials will be attempted before the system goes into lockout.	<ol style="list-style-type: none"> 1. Line voltage to L1 terminal of 50V51-250 must be 120 volts with reference to furnace chassis. 2. Furnace must be reliably connected to earth ground. 3. Induced blower moving main burner flame away from the flame sensor rod. 4. Inlet gas pressure too low for proper flame sensing. 5. Flame sensor rod contaminated or in incorrect position.
Main burner stays on after the end of the trial for ignition period.	Circulating fan is not turned on after 30-second time delay.	<ol style="list-style-type: none"> 1. Wiring between system control and IFC. Proper operation of 50V51-250 IFC.
Main burner goes out before thermostat call for heat ends.	4 Flash code comes on	<ol style="list-style-type: none"> 1. Open high limit switch. 2. High limit wiring in good condition and securely connected.
Main burner goes out before thermostat call for heat ends.	4 Flash code does not come on	<ol style="list-style-type: none"> 1. Induced blower moving main burner flame away from flame sensor rod. 2. Pressure switch has opened. 3. Flame sensor rod ceramic or leadwire overheated. 4. Gas supply / flow reduced or interrupted.
5 Flash code comes on.		<ol style="list-style-type: none"> 1. Open flame rollout switch 2. Rollout switch wiring in good condition
1 Flash code comes on. After 1-hour lockout reset delay, control will reset and initiate a new ignition sequence if the call for heat is still present.		<ol style="list-style-type: none"> 1. Gas supply off or at too low a pressure to operate furnace. 2. Damaged or broken HSI element. 3. Line voltage to L1 terminal of 50V51-250 IFC must be 120 volts with reference to the furnace chassis. 4. Furnace is not properly connected to earth ground. 5. Flame rod contaminated or in incorrect location. 6. Hot surface element located in incorrect position. 7. Hot surface element or flame sensing rod wiring in good condition and properly connected. 8. 5 flame failures caused by opening limit switch or flame rollout switch, within the thermostat call for heat. Turn thermostat down below room temperature to reset control. Check for blocked air filter, closed ducts, etc.

MODEL F80A

WHITE ROGERS 50A55-250 WIRING DIAGRAM

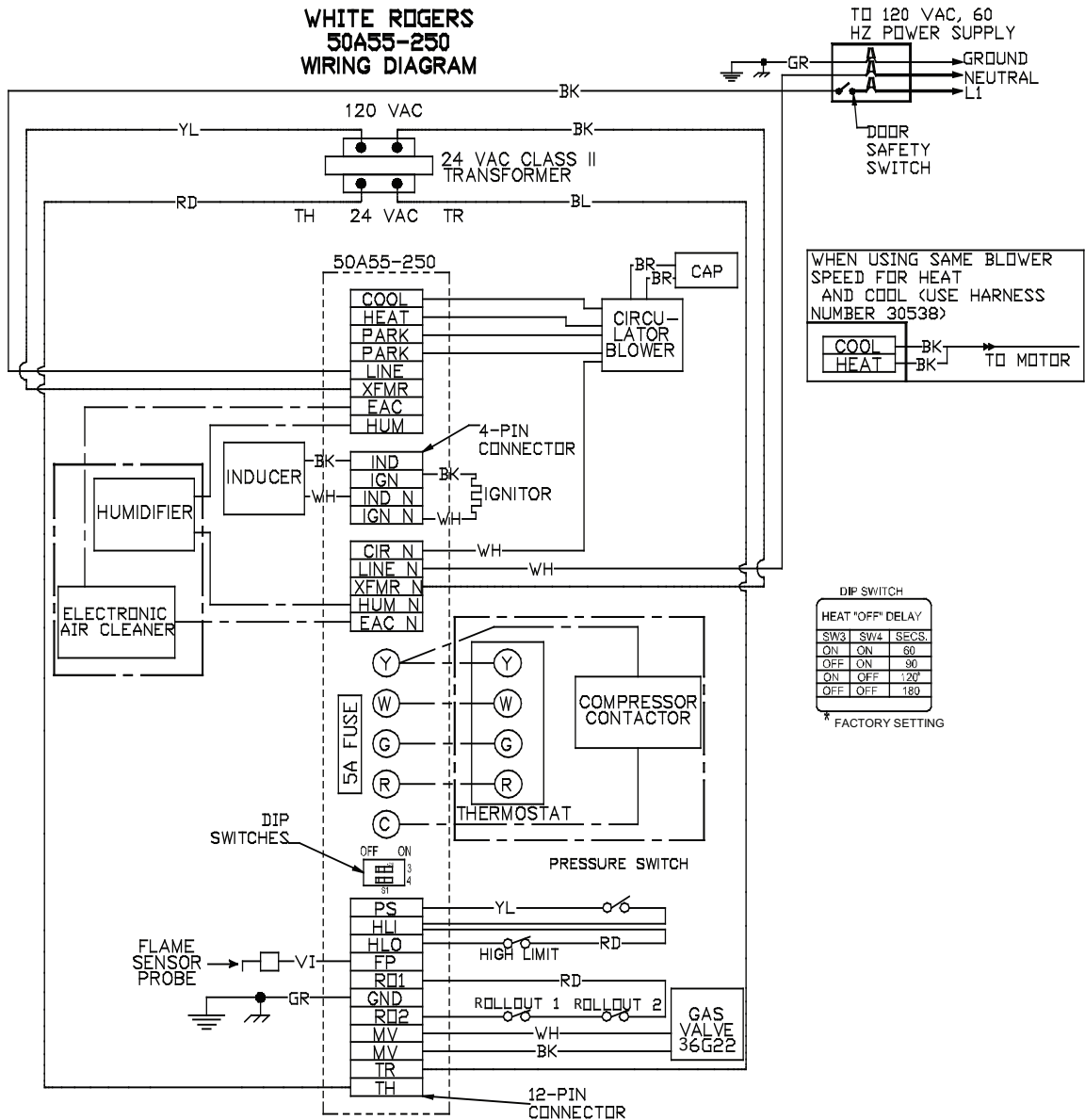

FEDDERS®

MODEL F80A SERIES GAS-FIRED WARM AIR FURNACE

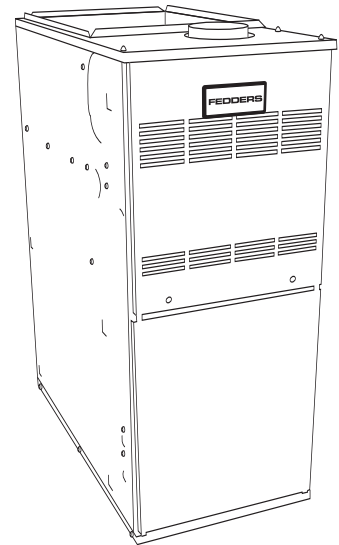

TABLE OF CONTENTS

FURNACE COMPONENTS	1
REGULATOR VENT	1
GENERAL SAFETY RULES	1
FURNACE OPERATION INFORMATION	
TO START THE FURNACE	2
FURNACE SHUTDOWN PROCEDURE	2
MAINTENANCE	
AIR FILTER	3
LUBRICATION	3
ROUTINE EXAMINATION	3
FURNACE APPEARANCE	4
CLEANING	3
SEQUENCE OF OPERATION	4

READ THESE INSTRUCTIONS THOROUGHLY BEFORE ATTEMPTING TO OPERATE THIS FURNACE.

This furnace has been designed to deliver many years of efficient, dependable service. With regular maintenance, some of which requires the attention of a qualified installer, service agency or gas supplier, some of which you may do yourself, the furnace will operate satisfactorily over many heating seasons.

Please read this manual to familiarize yourself with safety procedures, operation, and routine maintenance procedures.

⚠ WARNING ⚠

WHAT TO DO IF YOU SMELL GAS:

- DO NOT TRY TO LIGHT ANY APPLIANCE
- DO NOT TOUCH ANY ELECTRICAL SWITCH; DO NOT USE ANY PHONE IN YOUR BUILDING
- LEAVE THE BUILDING IMMEDIATELY
- IMMEDIATELY CALL YOUR GAS SUPPLIER FROM A PHONE OUTSIDE THE BUILDING. FOLLOW THE GAS SUPPLIER'S INSTRUCTIONS
- IF YOU CANNOT REACH YOUR GAS SUPPLIER, CALL THE FIRE DEPARTMENT
- INSTALLATION AND SERVICE MUST BE PERFORMED BY A QUALIFIED INSTALLER, SERVICE AGENCY OR THE GAS SUPPLIER

DO NOT USE THIS FURNACE IF ANY PART HAS BEEN UNDER WATER. A FLOOD DAMAGED FURNACE IS EXTREMELY DANGEROUS. ATTEMPTS TO USE THE FURNACE CAN RESULT IN FIRE OR EXPLOSION. A QUALIFIED SERVICE AGENCY SHOULD BE CONTACTED TO INSPECT THE FURNACE AND TO REPLACE ALL GAS CONTROLS, CONTROL SYSTEM PARTS, ELECTRICAL PARTS THAT HAVE BEEN WET OR THE FURNACE IF DEEMED NECESSARY.

FIRE OR EXPLOSION HAZARD

DO NOT STORE OR USE GASOLINE OR OTHER FLAMMABLE VAPORS AND LIQUIDS IN THE VICINITY OF THIS OR ANY OTHER APPLIANCE.

FAILURE TO FOLLOW SAFETY WARNINGS EXACTLY COULD RESULT IN SERIOUS INJURY, DEATH, OR PROPERTY DAMAGE.

MODEL F80A

FURNACE COMPONENTS

Figure 1 (below) is provided to help identify the components of your furnace.

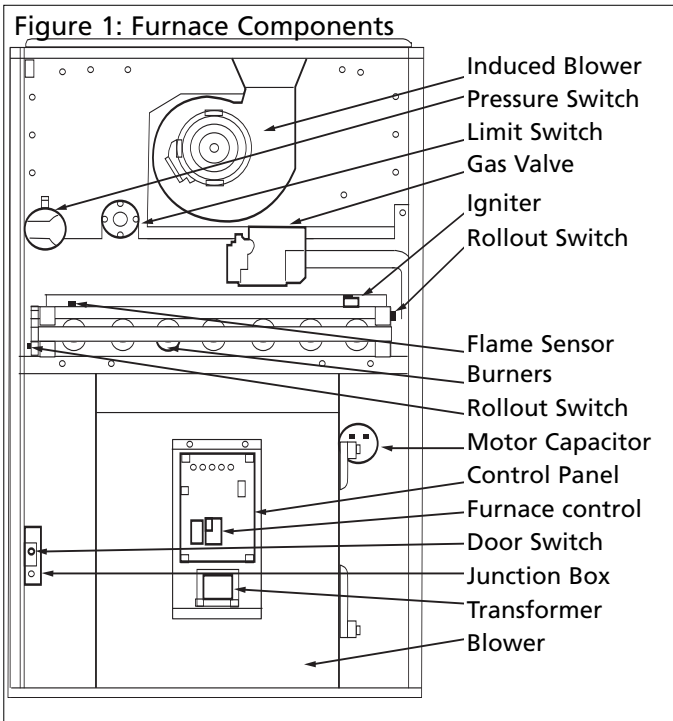

REGULATOR VENT

Most natural gas systems and all LP gas systems have a service regulator located near the point where the gas piping enters the building. The propane tank will normally have an additional first stage regulator located at the tank outlet valve. All of these regulators (located outdoors) will have a vent; see Fig. 2 (below).

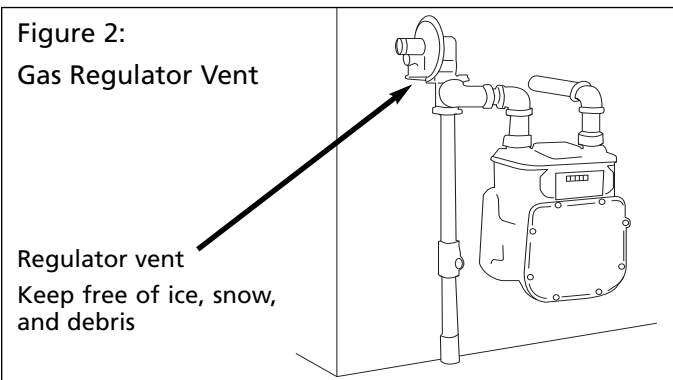

It is important for these vents to remain clear. Do not allow moisture, which could freeze, to build up in the vent. If you see moisture building up in the regulator vent, contact your gas supplier.

Your gas supplier should periodically inspect and clean the air vent screen to prevent any obstruction. Keep the protective regulator cover in place, as exposure to the elements can cause ice buildup and a regulator failure.

⚠ WARNING ⚠

AN OBSTRUCTED AIR VENT ON AN LP (PROPANE) CYLINDER OR TANK REGULATOR CAN CAUSE EXPLOSION OR FIRE RESULTING IN PROPERTY DAMAGE, SEVERE PERSONAL INJURY OR DEATH.

GENERAL SAFETY RULES

1. Combustible materials should not be stored against or around the furnace. Keep the furnace area clear and free from all combustible materials such as newspapers, rags, cardboard, clothing, etc. This applies especially to gasoline and other flammable vapors and liquids.
2. A furnace needs adequate amounts of combustion and ventilation air to operate properly. Do not block or obstruct air openings on the furnace, or air openings supplying combustion or ventilation air to the area where the furnace is installed. There are many areas from which your furnace could be receiving combustion and ventilation air including from within the heated area (inside air), from outdoors, from an attic or crawl space. If renovations are done, be sure that air supply openings are not inadvertently covered over with insulation, vapor barrier, or similar construction material.
3. All doors and panels must be in place during normal furnace operation. Attempting to operate the furnace with missing doors or panels could lead to the creation of carbon monoxide gas.
4. If the furnace is installed in a confined space or if you intend to build a furnace room where insulation is present, be aware that some insulating materials are combustible. Do not allow building insulating materials to come into contact with the furnace.
5. Any additions, alterations or conversions required in order for the furnace to properly match the application requirements must be done by a qualified installation contractor, service agency or gas supplier, using factory specified or approved parts.
6. Familiarize yourself with the location of the furnace gas manual shutoff valve and any electrical switches, fuse or circuit breaker associated with the furnace.
7. For your protection, the furnace is equipped with manually reset flame rollout switches. If either switch trips frequently, do not ignore this, call your installation contractor, service agency or gas supplier.
8. Should the gas supply fail to shut off or if overheating occurs, shut off the gas valve to the furnace before shutting off the electrical supply.
9. Familiarize yourself with the location of your furnace filter or filters. A blocked air filter will reduce efficiency, increase fuel consumption, raise the furnace operating temperature, and shorten the life of furnace components.
10. Do not cover return air grilles and supply air registers with drapes, curtains, throw rugs, etc.
11. Avoid shutting off supply air registers in the interests of saving heat. The furnace requires a sufficient quantity of air passing over the heat exchanger to operate within design temperatures, (system temperature rise). Reducing the availability of supply air registers may have the unforeseen consequence of raising the furnace operating temperature above design, thereby reducing furnace efficiency, and shortening the life of the furnace components.

FURNACE OPERATION INFORMATION

During the heating season, the operation of the furnace is fully automatic.

TO START THE FURNACE:

1. First read these instructions and safety notices thoroughly.
2. Set the thermostat to the lowest setting.
3. Ensure that all supply air registers and return air grilles are open.
4. Turn off the electric power to the furnace.
5. Remove the burner access door.
6. Ensure that the appliance manual shutoff valve is in the "ON" position. The valve handle is normally in-line with the gas pipe and valve body when it is in the "ON" position perpendicular to the gas piping and valve body when it is in the "OFF" position.
7. Wait 5 minutes to clear out any gas. If, after this time you smell gas, STOP. Turn the appliance manual shutoff valve to the "OFF" position. If burning propane or other LP gas, smell for gas near the floor since propane and butane are both heavier than air. If after this time you do not smell gas, continue to the next step.
8. Gas valve: Ensure that the Gas Valve Control is in the "ON" position, see Figure 3 at right.
9. Replace the burner access door, ensuring that it is properly in place.
10. Restore the electric power to the furnace.
11. Adjust the thermostat to the desired setting. If the thermostat also controls an air conditioning system, ensure that the thermostat system switch is in the "HEAT" or "AUTO" mode.

If this is the first time that the furnace has undergone a trial ignition since installation, or if there has been work done on the gas lines, the furnace might not light because of air trapped in the gas supply line.

Simply turn the thermostat down to its lowest setting, wait 5 minutes, then adjust the thermostat to the desired setting. If the problem persists, proceed to the Furnace Shut Down Procedure and call your installer, service agency or gas supplier.

If you intend to be away from home for lengthy periods of time during the non-heating season, it is advisable to follow the furnace shut down procedure.

⚠ WARNING ⚠

NEVER USE TOOLS TO TURN A MANUAL GAS CONTROL HANDLE. IF THE CONTROL HANDLE WILL NOT TURN BY HAND, DO NOT ATTEMPT TO FORCE IT. DOING SO COULD RESULT IN FIRE OR EXPLOSION RESULTING IN SERIOUS PERSONAL INJURY OR DEATH, OR PROPERTY DAMAGE. CALL A QUALIFIED INSTALLATION CONTRACTOR, SERVICE AGENCY OR GAS SUPPLIER.

FURNACE SHUTDOWN PROCEDURE

1. Set the thermostat to its lowest setting.
2. Shut off electric power to the furnace.
3. Turn the appliance manual shutoff valve to the "OFF" position.
4. Remove the burner access door, move the manual gas control switch to the "OFF" position, then reinstall the burner access door.

If you intend to be away from home for lengthy periods of time during the nonheating season, it is advisable to follow the furnace shutdown procedure.

Figure 3

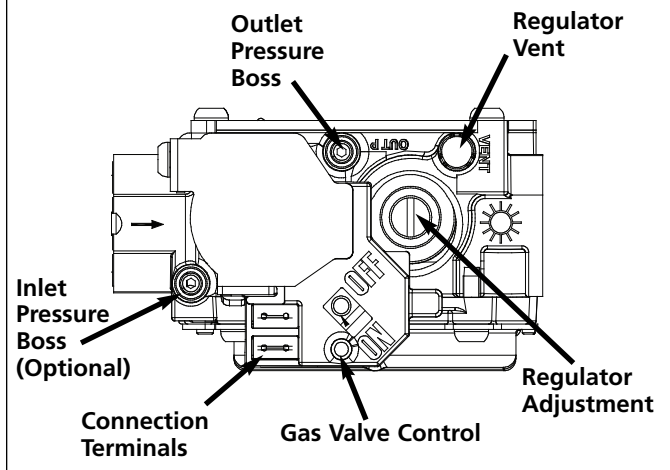

⚠ WARNING ⚠

DEVICES ATTACHED TO EITHER THE VENT OR COMBUSTION AIR INTAKE FOR THE PURPOSES OF EXCEEDING THE LIMITATIONS DESCRIBED IN THE INSTALLATION MANUAL, INCLUDING FIELD INSTALLED INDUCED BLOWER FANS HAVE NOT BEEN TESTED AND ARE NOT INCLUDED IN THE DESIGN CERTIFICATION OF THE FURNACE.

THE MANUFACTURER CANNOT AND WILL NOT SPECULATE ON THE EFFECTS OF SUCH MODIFICATIONS, AND CANNOT AND WILL NOT BE RESPONSIBLE FOR INJURY OR DAMAGE CAUSED BY THE USE OF SUCH UNTESTED AND/OR UNCERTIFIED DEVICES, ACCESSORIES OR COMPONENTS.

⚠ WARNING ⚠

IMPROPER INSTALLATION, ADJUSTMENT, ALTERATION, SERVICE OR MAINTENANCE CAN CAUSE PROPERTY DAMAGE, PERSONAL INJURY OR DEATH
FOR ASSISTANCE OR ADDITIONAL INFORMATION, CONSULT A QUALIFIED INSTALLER, SERVICE AGENCY, OR YOUR GAS SUPPLIER.

MAINTENANCE

AIR FILTER

REMOVING FILTER

1. Disconnect electrical power to the furnace.
2. Pull the filter out the front.
3. Replace with a fresh filter and reconnect power to the furnace. The filter will have an arrow indicating proper airflow direction.

DO NOT OPERATE YOUR FURNACE (OR AIR CONDITIONER) WITHOUT AN AIR FILTER.

⚠ WARNING ⚠
DISCONNECT THE ELECTRICAL POWER TO THE FURNACE BEFORE ATTEMPTING ANY MAINTENANCE. FAILURE TO DO SO MAY CAUSE ELECTRICAL SHOCK RESULTING IN SEVERE PERSONAL INJURY OR DEATH.

Consult your installation contractor or service technician if you have any questions on filters.

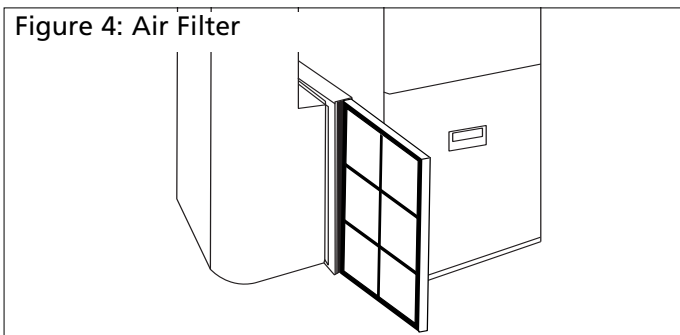

LUBRICATION

Minimal lubrication is required for your furnace. The induced blower assembly motors have sealed bearings. The bearings contain permanent special purpose lubricants. Attempting to force common oil into the induced blower motor bearings will deteriorate the original lubricant and shorten bearing life.

ROUTINE EXAMINATION

It is good practice to give a quick inspection of your furnace each time you inspect or clean the air filter. Things to check:

- All areas around the vent connector and chimney should be clear and free of obstructions.
- Check the venting to ensure that it is still fastened to the furnace. It should not sag and should have a slope upwards to the chimney. It should be physically sound, without holes or excessive corrosion.
- The return air duct connection must be sound and securely fastened to the furnace casing. In most cases, the filter rack provides the means to connect the return air to the furnace. There should be no return air inlets in the vicinity of the furnace.
- All ductwork should be secured to the furnace, and all ductwork should be solidly supported throughout the heating system.
- The furnace should be well supported on a level floor or by the means used to suspend the furnace in a horizontal configuration. Base support should be physically sound without sagging, cracks, gaps, etc. around the base so as to provide a seal between the support and the base.
- Check the furnace for obvious signs of deterioration.
- The gas burner should be observed from time to time during the heating season to ensure that the flames are clean and blue. A bit of orange color in the flame is not likely to be a problem and is probably dust particles burning. If you observe lazy yellow flames, call your heating or service contractor immediately. The yellow flames inevitably lead to sootups.

FURNACE APPEARANCE

The furnace exterior finish is a durable automotive-like coating. It may be washed with mild soap if necessary. Galvanized metal surfaces require no maintenance.

CLEANING

It is advisable to keep dust buildup on warm surfaces to a minimum, since dust, in some cases, can be combustible.

Dust buildup in the circulating fan can impair blower performance; therefore, reduce efficiency. Because the blower wheel is fastened directly to the blower motor, we recommend that major cleaning be left to your service contractor.

⚠ CAUTION ⚠
DO NOT PERMIT WATER OR CLEANING SOLUTIONS TO ENTER THE ELECTRIC MOTOR.

The burner area should be inspected and cleaned periodically. Be careful when cleaning around the burner area. The hot surface igniter is fragile and will break easily. Do not touch the hot surface igniter or flame rod.

⚠ WARNING ⚠
NEVER ATTEMPT TO CLEAN THE BURNER AREA WHILE THE BURNERS ARE OPERATING. DOING SO MAY RESULT IN EXPLOSION OR FIRE RESULTING IN SEVERE PERSONAL INJURY OR DEATH.

⚠ WARNING ⚠

ALWAYS DISCONNECT THE ELECTRICAL SUPPLY TO THE FURNACE BEFORE REMOVING THE BURNER COMPARTMENT ACCESS DOOR.

⚠ CAUTION ⚠

THE FURNACE SHOULD BE OPERATED WITH ALL PANELS IN PLACE. NEVER OPERATE THE FURNACE WITH THE BLOWER DOOR REMOVED EXCEPT FOR SERVICE PURPOSES.

The furnace achieves its mid-efficiency in two general areas. First, there is no wasteful standing pilot. The furnace consumes no gas in between cycles. Secondly, the furnace is designed to allow very small amounts of excess air in the combustion process. Older furnaces had heat exchangers that were commonly 40% larger than necessary for complete combustion. While this prevented the creation of carbon monoxide, the heated excess air was expelled up the chimney where it could not benefit the interior of the home. Special safety controls now prevent the formation of carbon monoxide.

IMPORTANT

Your furnace should be cleaned and inspected annually by a trained and qualified service technician.

Your service technician has the knowledge and test equipment to determine the condition of your furnace.

⚠ WARNING ⚠

THE EXHAUST GASES FROM THIS FURNACE CONTAIN CHEMICALS, WHICH ON SOME OCCASIONS MAY INCLUDE CARBON MONOXIDE (CO). CARBON MONOXIDE IS AN ODORLESS, TASTELESS, CLEAR COLORLESS GAS, WHICH IS HIGHLY TOXIC. EVEN LOW CONCENTRATIONS ARE SUSPECTED OF CAUSING BIRTH DEFECTS AND OTHER REPRODUCTIVE HARM.

UL AND CUL RECOGNIZED CO DETECTORS ARE RECOMMENDED FOR ALL BUILDINGS EQUIPPED WITH FOSSIL FUEL BURNING APPLIANCES. ALL CO DETECTORS SHOULD BE INSTALLED IN ACCORDANCE WITH THEIR MANUFACTURER'S INSTRUCTIONS AND APPLICABLE LOCAL BUILDING CODES.

SEQUENCE OF OPERATION

1. Thermostat, responding to cool room, calls for heat.
2. Combustion air blower begins.
3. After 15 second prepurge, hot surface igniter warms up.
4. After approximately 5 seconds, the gas valve will open, and the burners ignite.
5. Thirty seconds after the burners ignite and flame sense is proven, the main blower starts on the heating speed.
6. System remains in this state until the room air temperature rises causing the thermostat to terminate its call for heat.
7. The gas valve shuts off; the burners extinguish.
8. After brief postpurge period, (5 seconds), the combustion air fan stops. The main blower continues to run. Elapsed time ranges from 60 seconds to 180 seconds, depending on the manufacturer's requirement.
9. The furnace remains idle until the next call for heat.

VARIATIONS

If your system includes air conditioning, your thermostat (supplied by the installer) will likely have two switches. The first switch is the system switch. The switch settings usually include HEAT, COOL, and OFF. Some thermostats have system switches which include HEAT, COOL, AUTO, and OFF. The system switch must be in the HEAT or AUTO position for the furnace to run.

The second switch is the fan switch. It usually has settings of ON and AUTO. The fan switch may be in either position when using the furnace. If the fan switch is set to ON, the main blower will run continuously, and the blower delays mentioned in the sequence of operation points 5 and 9 will be ignored.

The information in this manual supersedes and replaces the previous instruction/operation manual with regards to Warm Air Furnace products. Illustrations cover the general appearance of the units at the time of publication and the manufacturer reserves the right to make changes in design and construction at any time without notice.

For replacement parts contact:

Airwell Fedders North America

2 Centre Drive, Monroe Township, NJ 08831

Phone: 1-866-829-2440