



INSTALLATION & OPERATING INSTRUCTIONS for GMNT CONDENSING GAS FURNACE

(CATEGORY IV)



WARNING

THIS FURNACE IS DESIGN CERTIFIED FOR INSTALLATION IN BUILDINGS CONSTRUCTED ON SITE ONLY.



WARNING

CARBON MONOXIDE (REFERRED TO AS CO) CAN CAUSE SERIOUS PERSONAL INJURY OR DEATH.



WARNING

DO NOT USE THIS FURNACE IF ANY PART HAS BEEN UNDER WATER. IMMEDIATELY CALL A QUALIFIED SERVICE TECHNICIAN TO INSPECT THE FURNACE AND TO REPLACE ANY PART OF THE CONTROL SYSTEM AND ANY GAS CONTROL THAT HAS BEEN UNDER WATER.



WARNING

IF THIS FURNACE IS INSTALLED IN AN ENCLOSED AREA, SUCH AS A GARAGE OR UTILITY ROOM, EITHER ALONE OR WITH ANY OTHER CARBON MONOXIDE PRODUCING DEVICE (E.G. AUTOMOBILE, SPACE HEATER, WATER HEATER, ETC.), ENSURE THAT THE ENCLOSED AREA IS PROPERLY VENTILATED.

All information contained herein is subject to change without notice.

INDEX	
REPLACEMENT PARTS	2
WARNINGS	2
GENERAL INFORMATION	3
LOCATION, CLEARANCES	4
COMBUSTIONAIR	4
VENTING	5
CONDENSATE DRAINS	8
GAS PIPING	11
CIRCULATINGAIR	11
ELECTRICAL SUPPLY CONNECTIONS	12
CONTROL VOLTAGE CONNECTIONS	12
FEATURES	12
RATING THE FURNACE	13
TIMING THE GAS METER	13
SPECIAL INSTRUCTIONS FOR WHITE RODGERS 36G22 GAS VALVE ADJUSTMENT	14
SAFETY CONTROL	15
CIRCULATINGAIR FILTERS	16
TEMPERATURE RISE	16
MOTOR LUBRICATION AND MAINTENANCE	16
SERVICE INSTRUCTIONS	16
SEQUENCE OF OPERATION	16
REMOVING AN EXISTING APPLIANCE	17
INSPECTING AND CLEANING THE HEAT EXCHANGER	17
LIGHTING INSTRUCTIONS	18
WIRING DIAGRAM	19

HEAT EXCHANGER
Heat exchanger sections
Secondary coil
Collector Box
ELECTRICAL CONTROLS
Control board
Auxiliary / main limit switch
Roll-out switch
Transformer
Door interlock switch
Air pressure switch
Induced draft blower
BURNER ASSEMBLY
Burners
Manifold
Orifices
Gas Valve
Igniter
Flame sensor
MISCELLANEOUS
Wrapper
Access doors
Chimney
Gaskets and seals
Wiring assemblies

In order to effectively process the parts requirement the distributor / contractor will need the entire model number and serial number found on the series and rating plate located inside the blower compartment.

THIS FURNACE CONTAINS ELECTRONIC COMPONENTS, WHICH REQUIRE A DEFINITE GROUND. PROVISIONS ARE MADE FOR CONNECTION OF THE GROUND. A DEDICATED GROUND FROM THE MAIN POWER SUPPLY OR AN EARTH GROUND MUST BE PROVIDED.

REPLACEMENT PARTS

Replacement parts for this appliance are available through your contractor or local distributor. For the location of your nearest distributor consult the white business pages, the yellow page section of the local telephone book or contact:

SERVICE PARTS DEPARTMENT
GOODMAN MANUFACTURING CO., L.P.
2550 NORTH LOOP WEST, SUITE 400
HOUSTON, TEXAS 77092
(713) 861 – 2500

The major parts groups are as follows:

BLOWER ASSEMBLY

- Motor
- Blower Housing
- Blower wheel
- Misc. sheetmetal items
- Capacitor



DANGER
PELIGRO

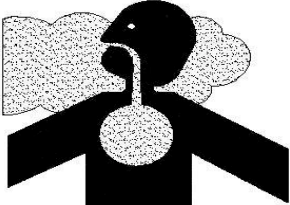

CARBON MONOXIDE POISONING HAZARD

Special Warning for Installation of Furnace or Air Handling Units in Enclosed Areas such as Garages, Utility Rooms or Parking Areas

Carbon monoxide producing devices (such as an automobile, space heater, gas water heater, etc.) should not be operated in enclosed areas such as unventilated garages, utility rooms or parking areas because of the danger of carbon monoxide (CO) poisoning resulting from the exhaust emissions. If a furnace or air handler is installed in an enclosed area such as a garage, utility room or parking area and a carbon monoxide producing device is operated therein, there must be adequate, direct outside ventilation.

This ventilation is necessary to avoid the danger of CO poisoning which can occur if a carbon monoxide producing device continues to operate in the enclosed area. Carbon monoxide emissions can be (re)circulated throughout the structure if the furnace or air handler is operating in any mode.

CO can cause serious illness including permanent brain damage or death.

B10259-216



WARNING

WHILE **CARBON MONOXIDE** DETECTORS DO PROVIDE ADDITIONAL PROTECTION, LIMITATIONS TO THEIR EFFECTIVENESS REQUIRE THAT YOU OTHERWISE CONTINUE TO FOLLOW APPROPRIATE INSTRUCTIONS LOCATED IN THE "INSTALLATION & OPERATING INSTRUCTIONS" AND "USER'S INFORMATION MANUAL" RELATING TO PROTECTING PERSONS FROM THE RISKS OF **CARBON MONOXIDE**. REVIEW EACH CO DETECTOR'S MANUFACTURERS' EXPLANATION OF THEIR UNIT'S CAPABILITIES AND FOLLOW THE INSTALLATION AND OPERATING MANUAL WHEN INSTALLING AND OPERATING SUCH UNITS.



WARNING

THE CIRCULATING AIR DUCTS MUST BE COMPLETELY AND POSITIVELY SEALED TO PREVENT THE COMBUSTION PRODUCTS, INCLUDING CARBON MONOXIDE, FROM ENTERING THE LIVING SPACE.



WARNING

TO ENSURE PROPER INSTALLATION AND OPERATION OF THIS PRODUCT, COMPLETELY READ AND UNDERSTAND THESE INSTRUCTIONS PRIOR TO ATTEMPTING TO ASSEMBLE, INSTALL, MAINTAIN, OR REPAIR. IF THESE INSTRUCTIONS ARE NOT FOLLOWED PRECISELY THERE IS A POTENTIAL OF CARBON MONOXIDE POISONING, WHICH CAN RESULT IN SERIOUS ILLNESS OR DEATH.



WARNING

UNLESS ALLOWED BY LOCAL CODE, DO NOT INSTALL A LIQUID PETROLEUM GAS BURNING APPLIANCE IN A PIT, BASEMENT, OR SIMILAR LOCATION. L.P., A HEAVIER THAN AIR GAS, CAN COLLECT IN LOW AREAS AND MAY NOT DISPERSE NATURALLY. APPLIANCES SO FUELED SHALL NOT BE INSTALLED IN AN ABOVE GRADE UNDER FLOOR SPACE OR BASEMENT UNLESS SUCH LOCATION IS PROVIDED WITH APPROVED MEANS FOR REMOVAL OF UNBURNED GAS.



WARNING

THIS FURNACE WAS EQUIPPED AT THE FACTORY FOR USE WITH NATURAL GAS ONLY. LIQUID PETROLEUM (L.P.) CONVERSION, IF REQUIRED, MUST BE PERFORMED BY A QUALIFIED TECHNICIAN FAMILIAR WITH PERFORMING THIS TYPE OF CONVERSION. IF L.P. CONVERSION IS REQUIRED, ALL INSTRUCTIONS INCLUDED WITH THE FACTORY AUTHORIZED KIT MUST BE FOLLOWED. THE ONLY KIT THAT MUST BE USED FOR THIS CONVERSION IS THE FACTORY AUTHORIZED LPT-01. FAILURE TO FOLLOW THOSE INSTRUCTIONS EXPLICITLY MAY CAUSE FIRE, EXPLOSION, PROPERTY DAMAGE, PERSONAL INJURY OR DEATH.



WARNING

NEVER LAY THIS FURNACE ON ITS FRONT OR REAR.



WARNING

HEATING UNIT SHOULD NOT BE UTILIZED WITHOUT REASONABLE, ROUTINE, INSPECTION, MAINTENANCE AND SUPERVISION. IF THE BUILDING IN WHICH ANY SUCH DEVICE IS LOCATED WILL BE VACANT, CARE SHOULD BE TAKEN THAT SUCH DEVICE IS ROUTINELY INSPECTED, MAINTAINED AND MONITORED. IN THE EVENT THAT THE BUILDING MAY BE EXPOSED TO FREEZING TEMPERATURES AND WILL BE VACANT, ALL WATER-BEARING PIPES SHOULD BE DRAINED, THE BUILDING SHOULD BE PROPERLY WINTERIZED, AND THE WATER SOURCE CLOSED. IN THE EVENT THAT THE BUILDING MAY BE EXPOSED TO FREEZING TEMPERATURES AND WILL BE VACANT, ANY HYDRONIC COIL UNITS SHOULD BE DRAINED AS WELL AND, IN SUCH CASE, ALTERNATIVE HEAT SOURCES SHOULD BE UTILIZED.

GENERAL INFORMATION

The GMNT series furnace can be installed as an upflow, downflow or horizontal furnace. It can also be installed as a direct vent or a non-direct vent furnace.

These Installation and Operating Instructions are intended for use by fully qualified installation technicians. Some localities require the installer/sevicer to be licensed. If in doubt, check with local authorities.

INSTALLATION: In the USA, this furnace MUST be installed in accordance with the latest edition of the ANSI Z223.1 booklet entitled "National Fuel Gas Code" (NFPA 54), and the requirements or codes of the local utility or other authority having jurisdiction. In Canada, this furnace must be installed in accordance with the current CAN/CGA-B149.1 & 2 Gas Installation Codes, local plumbing or waste water codes and other applicable codes.

Additional helpful publications available from the NFPA are, NFPA 90A - Installation of Air Conditioning and Ventilating System and NFPA 90B - Warm Air Heating and Air Conditioning System.

All venting shall be in accordance with PART 7, Venting of Equipment, of the National Fuel Gas Code, ANSI Z223.1, or applicable local building and/or air conditioning codes.

These publications are available from:

National Fire Protection Association, Inc.
Batterymarch Park
Quincy, MA 02269

The GMNT series of furnaces meet the California NOx emission standards and California seasonal efficiency standards. ANNUAL inspections of the furnace and its vent system is strongly recommended. It is the installer's responsibility to inform the user of this importance. Any installation, alteration or repair of this equipment must not be in violation of local code or the information contained in this manual. This furnace shall be securely fastened in place when installed in the vertical position. This furnace must be installed in such a manner as to allow for service, inspection, repair or replacement without removing permanent construction. A platform is recommended to allow for service.

LOCATION

- **DO NOT** install this furnace in a mobile home. This furnace is designed only for installation in buildings constructed on site and connected to ductwork. When installed in a utility room or closet, the door should be wide enough to allow the largest part of the furnace to enter, or to permit the replacement of another appliance, such as a water heater. This furnace is designed to be installed indoors only.
- **DO NOT** install outdoors. This furnace should be installed in such a manner so that it is protected from water. If any components should become wetted or submerged under water, replace those parts before returning the furnace to operation.
- **DO NOT** use as a construction heater.
- **DO NOT** use in an area where freezing may occur without properly protecting the vent and drain system. The drain may crack and leak if subjected to freezing temperatures.
- **DO NOT** install in a room used or designed to be used as a bedroom, bathroom or storage closet, or in any enclosed space with access only through such a room or space.

A return air filter grille or means of inserting a filter into the return air duct is recommended. The opening in the duct used for filter access must be capable of being sealed air tight if located in the same pressure zone as the furnace.

The furnace and it's individual shut-off must be disconnected from the gas supply piping system during any pressure testing of that system at test pressures in excess of 1/2 psig (3.5kPa)

The furnace must be isolated from the gas supply piping system by closing it's individual manual shut-off valve during any pressure testing of the gas supply piping system at pressures equal to or less than 1/2 psig (3.5 kPa).

CLEARANCES

MIN. CLEARANCES TO COMBUSTIBLE SURFACES

Unobstructed front clearance of 24" for servicing is recommended.

RIGHT SIDE - 1"

VENT - 0"

REAR - 0"

LEFT SIDE - 1"

TOP OF PLENUM - 1"

FRONT - 3"

Line contact is permitted in the horizontal position.

ACCESSIBILITY CLEARANCE, WHERE GREATER, SHOULD TAKE PRECEDENCE OVER MINIMUM FIRE PROTECTION CLEARANCE.

A gas-fired furnace for installation in a residential garage must be installed so that the ignition source and burners are located not less than eighteen inches (18") above the floor and is protected or located to prevent physical damage by vehicles.

A gas furnace must not be installed directly on carpeting, tile, or other combustible materials other than wood flooring.



WARNING

A SOLID METAL BASEPLATE IS SUPPLIED WITH THIS FURNACE. THIS BASEPLATE MUST BE IN PLACE AND SEALED AIR TIGHT WHEN THE FURNACE IS INSTALLED WITH SIDE RETURN AIR DUCTS. FAILURE TO DO SO MAY PERMIT COMBUSTION PRODUCTS, INCLUDING CABON MONOXIDE, TO ENTER THE LIVING SPACE AND CREATE POTENTIALLY HAZARDOUS CONDITIONS SUCH AS **CARBON MONOXIDE** POISONING OR DEATH. FULL SIZE RETURN AIR DUCT OPENINGS MUST BE UTILIZED. EMBOSSES ARE PROVIDED FOR THIS PURPOSE.

Before proceeding with this installation check the following:

- Correct clearance from combustible materials
- Adequate accessibility for servicing
- Flooring is not carpet or any other combustible material, except wood
- Adequate combustion / ventilation air is supplied
- Metal base plate is in place when using side(s) for return air
- In a garage, the furnace has been adequately elevated and protected from vehicle damage
- Furnace area is free of flammable materials and vapors such as gasoline

COMBUSTION AIR

The GMNT furnace can be installed either as a Direct Vent (2 pipe) or a Non-Direct Vent (1 pipe) appliance. If installed as direct vent appliance, the combustion air is to be taken from the outdoors via a 2" or 3" schedule 40 PVC pipe and terminate at the furnace burner box. As a non-direct vent furnace, the combustion air is taken from the area which the furnace is installed. Avoid combustion air sources that contain flammable fumes and vapors, and gasses such as carbon monoxide, hydrogen sulfide, ammonia, chlorine, and halogenated hydrocarbons.

Direct Vent Combustion Air. As shown in the following illustration, the combustion air pipe is to originate at the furnace's cabinet and terminate outside of the building. The diameter of the PVC combustion air pipe depends upon the furnace size, the length of pipe, and the quantity of fittings employed. The table found in the "Combustion/Vent Pipe Size" section of this manual outlines these sizing requirements. As a direct vent installation, the "Air for Combustion and Ventilation Air" requirements found in ANSI Z223.1, section 5.3 is not required for the furnace to operate correctly. However, other fuel burning appliances located in the same space as the furnace may still require that the area be serviced with Combustion and Ventilation Air consistent with ANSI Z223.1, section 5.3.

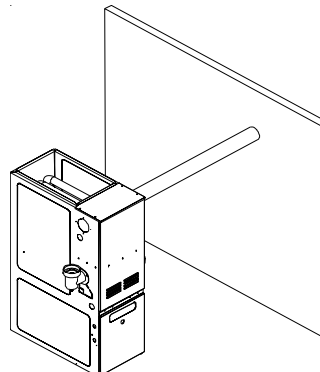

WARNING

COMBUSTIBLE MATERIAL MUST NOT BE PLACED ON OR AGAINST THE FURNACE CABINET. THE AREA AROUND THE FURNACE MUST BE KEPT CLEAR AND FREE OF ALL COMBUSTIBLE MATERIAL INCLUDING GASOLINE AND OTHER FLAMMABLE VAPORS AND LIQUIDS. THE USER MUST BE CAUTIONED THAT THE FURNACE AREA MUST NOT BE USED AS A BROOM CLOSET OR FOR ANY OTHER STORAGE PURPOSE.

Attaching Combustion Air Intake Fitting. A coupling for attaching the combustion air fitting to the furnace cabinet is included in a plastic bag packaged with the furnace. The fitting is sized to accept a 3" diameter PVC pipe. In certain situations, a 2" diameter pipe can be used for this application. Refer to the combustion/ vent table for sizing requirements. Attach the fitting to the cabinet using (4) #10 x 1/2" sheet metal screws (field supplied). If a right hand entrance is preferred, the plug installed on this side is to be removed and reinstalled in the left side opening.

Non-Direct Vent Combustion Air. If the furnace is to be installed as a non-direct vent appliance, the combustion air pipe outlined previously is not used.

As a non-direct vent furnace, this must be installed in accordance with the combustion and ventilation air requirements found in ANSI Z221.3, section 5.3. When installed as a non-direct vent furnace in an area, which is deemed as a confined area, see (ANSI Z223.1, section 1.7, "Space, Confined") the requirements are as follows:

All Combustion Air Taken From The Inside Of The Building. When installed as a non-direct vent furnace and indoor air is used as the combustion air source, the space is to be provided with (2) permanent openings communicating directly with an additional room(s) of sufficient volume so that the combined volume of all spaces meets the criteria of an unconfined area. The total input of all gas burning equipment shall be used to determine the minimum size of each opening. Each opening shall be sized to be a minimum of 1 square inch of free area per 1,000 Btu/hr of combined input of gas utilization equipment in the area. The minimum area for each opening shall not be less than 100 square inches, and the minimum dimension of these openings shall not be less than 3 inches. One opening shall commence within 12 inches of the top of the area, while the other opening shall commence within 12 inches of the bottom of the area.

All Combustion Air Taken From Outdoors. If installed as a non-direct furnace and outdoor air is selected as the combustion air source, then area shall be serviced with an opening(s) communicating directly with the outdoors by either of the following two methods. When calculating the minimum area for each opening, the combined input of all gas utilization equipment is to be considered. Also, the minimum dimension for any opening shall not be less than 3 inches.

Method 1..... Two permanent openings communicating directly with the outdoors via horizontal ducts shall be sized to be a minimum of 1 square inch per 4,000 Btu/hr or, two permanent openings communicating directly with the outdoors via vertical ducts shall be sized to be a minimum of 1 square inch per 2,000 Btu /hr.

Method 2..... One permanent opening communicating directly with the outdoors via a horizontal duct. This opening/duct shall be sized to be equal to 1 square inch per 3,000 Btu / hr, but not less than the sum of the areas all of the vent connectors in the confined space.

When installed as a direct vent furnace and NOT using the concentric vent kit CVK-00 option, the combustion air is to be terminated in the following manner;

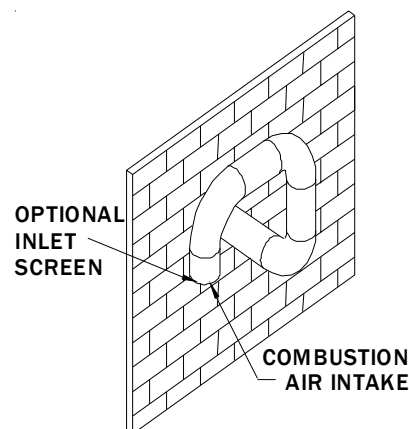

If the optional concentric vent kit (CVK-00) is used, follow the instructions provided with this accessory.

SOURCE OF COMBUSTION AIR

The recommended source of combustion air is to use the outdoor air supply. However, the use of indoor air in most applications is acceptable except as follows;

1. If the furnace is installed in a confined space, the necessary combustion must come from outdoors by way of the attic, crawl space, or direct opening to the outside.
2. If indoor combustion is used, there must be no exposure to the substances listed in #3 below.
3. The following installations may require OUTDOOR AIR for combustion, due to chemical exposures;
 - Commercial buildings
 - Buildings with indoor pools
 - Furnaces installed in laundry rooms
 - Furnaces installed in hobby or craft rooms
 - Furnaces installed near chemical storage areas

Exposures to the following substances in the combustion air supply may also require OUTDOOR AIR for combustion;

- Permanent wave solutions
- Chlorinated waxes and cleaners
- Chlorine based swimming pool chemicals
- De-icing salts or chemicals
- Carbon tetrachloride
- Halogen type refrigerants
- Cleaning solvents (such as perchloroethylene)
- Printing inks, paint removers, varnishes, etc.
- Hydrochloric acid
- Cements and glues
- Antistatic fabric softeners for clothes dryers
- Masonry acid washing materials

VENTING

ANNUAL inspections of the furnace and it's vent / combustion air supply is strongly recommended. It is the contractor's responsibility to inform the user of this importance. All venting shall be in accordance with Part 7; Venting of Equipment, of the National Fuel Gas Code, ANSI Z223.1, or applicable local building and/ or air conditioning codes.

PROPER INSTALLATION OF THE VENT / COMBUSTION AIR SYSTEMS IS CRITICAL TO SAFE OPERATION OF THIS APPLIANCE. CAREFULLY READ AND UNDERSTAND THE INSTRUCTIONS IN THIS SECTION. EACH VENT AND COMBUSTION AIR SUPPLY PIPE MUST SERVE ONLY ONE

APPLIANCE. DO NOT CONNECT TO AN EXISTING VENT OR CHIMNEY UNLESS IT CONFORMS TO ALL PROVISIONS IN THIS INSTRUCTION BOOKLET. **THE VENT MUST TERMINATE OUTDOORS.**

VENT/COMBUSTION AIR SUPPLY PIPE LENGTHS

Elbows must be long radius types. (Quarter bends or DWV). The maximum length of the vent pipe and the combustion air supply pipe is 100 feet each.

Model GMNT	Vent @ 45 ft. or less	Vent @ more than 45 ft.	Comb. Air @ 45 ft. or less	Comb. Air @ More than 45 ft.
040-3	2 in.	3 in.	2"	3"
060-3	2 in.	3 in.	2"	3"
080-4	3 in.	3 in.	3"	3"
100-4	3 in.	3 in.	3"	3"
120-5	3 in.	3 in.	3"	3"

Chart assumes a maximum of 4 - 90° elbows. For excess of 4 elbows decrease length by 7.5 ft. per elbow. A maximum of 6 elbows is acceptable. The use of two 45° over one 90° is preferred. Do not count the termination as an elbow.

Minimum vent length is 6 ft. for vertical and horizontal runs. There is no minimum combustion air supply pipe length.

These furnaces are a condensing type appliance. The products of combustion are recirculated through a secondary coil. During this process the flue products are brought to a point below dew point. Thus the moisture present in the flue products condenses leaving a liquid by-product. This by-product must be removed from the furnace and it's collection system.

In addition, the vent temperatures are also considerably lower than conventional furnaces. This allows the use of low temperature plastic as the vent system. The recommended plastic is schedule 40 PVC, ABS, DWV (or equivalent if allowed by local code). See the previous chart for proper sizing. The use of two 45° elbows is suggested over the use of a single 90° elbow. The vent pipe must slope toward the furnace to properly drain the condensate. The drain trap and related parts must be installed as shown in the illustrations. Failure to follow these instructions can cause products of combustion including **CARBON MONOXIDE** entering the dwelling.

IF THIS FURNACE IS INSTALLED IN AN ATTIC OR SIMILAR AREA WHERE CONDENSATE OVERFLOW MAY BE A PROBLEM, AN AUXILIARY DRAIN PAN MUST BE INSTALLED UNDER THE FURNACE WITH THE AUXILIARY DRAIN LINES ROUTED TO THE OUTDOORS TO PREVENT WATER DAMAGE CAUSED BY LEAKS.

THE COMBUSTION PRODUCTS AND MOISTURE IN THE FLUE GASES WILL CONDENSE. THE CONDENSATE MAY FREEZE ON THE EXTERIOR WALL AND SURROUNDING SURFACES. SOME DISCOLORATION OR ETCHING IS TO BE EXPECTED.

THE VENT AND COMBUSTION AIR SUPPLY PIPES MUST BE INSPECTED ANNUALLY.

Visually check the vent terminal and combustion air supply pipe screens, clean if necessary. Visually check for blockage of the condensate disposal system. Hoses may

be disconnected to determine that proper flow is maintained. Should an obstruction be observed, it can be dislodged by forcing a stream of water through it using a device such as a garden hose.

Materials and procedures must conform to:

The ASTM Standards.

Pipe and Fittings ASTM 1785, D2465 and D2266

PVC Primer and Solvent Cement ASTM D2564

Procedure for Cementing Joints ASTM D2855 (ref.) This appliance may be vertically or horizontally vented.

HORIZONTAL THROUGH THE WALL VENTING

This appliance may be horizontally vented through an exterior wall following the applicable instructions in the "VENTING" section in conjunction with these additional requirements. A wall sleeve must be used.

ALL HORIZONTAL VENT INSTALLATIONS MUST BE MADE IN ACCORDANCE WITH THESE INSTRUCTIONS.

When selecting which exterior wall to penetrate, the following items should be taken into consideration:

1. Layout the combustion air and vent system to avoid the possibility of interference with beams, poles, posts, electrical wiring, plumbing, etc.
2. When possible, the combustion air and vent termination should not be subjected to prevailing winds.
3. The combustion air intake and vent termination must be located at least twelve (12) inches above expected snowfall. Consideration should be made to past unusual snowfalls.
 - **DO NOT** locate the terminal less than seven (7) feet above public walkways. This applies to steps and stairwells.
 - **DO NOT** locate the termination areas where condensate may present a problem such as flowerbeds, patios, etc.
 - **DO NOT** locate within four (4) feet of a gas meter, electric meter, or gas regulator; (3) feet in Canada
 - **DO NOT** locate the vent terminal within four (4) feet of an adjacent building.
 - **DIRECT VENT INSTALLATION - DO NOT** locate the vent terminal within twelve (12) inches of an operable window or door.
 - **NON-DIRECT VENT INSTALLATION - DO NOT** locate the vent terminal less than (12) inches above a door or operable window.
 - **NON-DIRECT VENT INSTALLATION - DO NOT** locate the vent terminal less than (4) feet below or (4) feet horizontally from any door, window or gravity air inlet into any building.
 - **DO NOT** locate the vent terminal less than three (3) feet above, or (10) feet horizontally from, a forced air inlet into any building, other than the combustion air supply pipe.
 - **DO NOT** locate the vent terminal within three (3) feet of an inside corner of a building or structure. Minor corners created by fireplace chimneys are excluded from this requirement.

To protect the exterior surface from staining due to the condensate, an aluminum plate or similar material may be installed surrounding the termination. This plate should extend approximately two (2) feet from the termination.



WARNING

THE AREA SURROUNDING THE VENT TERMINAL AND COMBUSTION AIR SUPPLY PIPE MUST BE KEPT FREE OF SNOW, TRASH, BUSHES OR ANY OTHER OBSTACLE WHICH COULD CAUSE **CARBON MONOXIDE** TO ENTER THE BUILDING.

SUPPORTING AND PITCHING THE VENT AND COMBUSTION AIR SUPPLY PIPE.

All horizontal runs must be supported at least every five (5) feet and at joints with straps or hangers. No sags or dips are permitted. The pipes must be saddles supported only. Do not secure the hangers or straps tightly to the pipes to allow for expansion and contraction of the vent pipe. Maintain a 1/4" per foot minimum pitch upward on the horizontal vent pipe from the drain to the terminal. This will allow the condensate to flow into the drain system and not out the terminal. Vertical runs must be supported a minimum of every six (6) feet.

The combustion air supply pipe should be pitched slightly downward at the inlet to prevent water from entering the pipe.

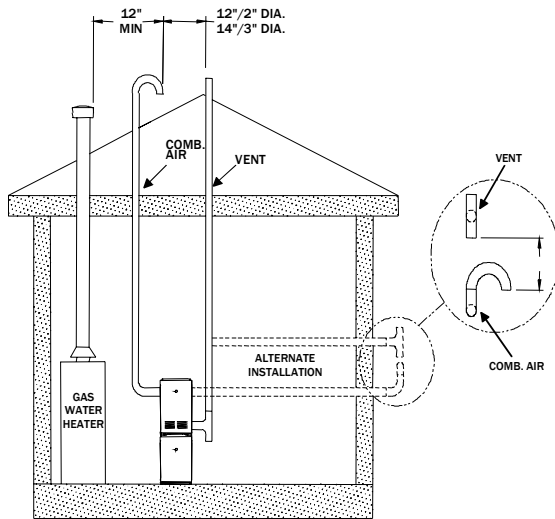

VENT TERMINATION

When the horizontal vent option is used the vent pipe is to be terminated with a "Tee" fitting. A debris screen (packaged with the furnace) is to be installed on each open end of the termination tee. When vertically vented no termination fitting is required. However, to accommodate the debris screen, a coupling is to be attached to the end of the vent pipe. The debris screen is to be glued into the coupling.

JOINING PIPE AND FITTINGS

Proper installation of the vent/combustion air system is critical to safe operation of this product. Carefully read and understand the instructions in this section. Do not connect to an existing vent or chimney.

Provisions are made for the connection of outside combustion air to the furnace casing. This connector may be moved to the opposite side of the furnace by removing the screws securing the collar, removing the large plug on the side of the furnace and reconnecting both.

The plastic plugs must be in place when installed as a direct vent unit.

When utilizing indoor air for combustion in unconfined spaces, it is not necessary to connect any pipe to the collar. It is recommended that the plug is removed and both sides be used for supplying combustion air.

When installed in the horizontal position in unconfined spaces, a short length of pipe, a coupling and the screen must be in place, facing up or the air may be obtained from the bottom of the unit providing there is at least 4" of unobstructed space. It is recommended that the plug is removed and the combustion air supply is obtained from both openings.

A pitch of 1/4" per foot toward the drain assembly is recommended for proper drainage.

The GMNT series of gas furnace is a condensing type appliance. The products of combustion are recirculated through a secondary coil. During this process, the flue products are brought to a temperature below dew point. Thus the moisture present in the flue products condense, leaving a liquid by-product. This by-product must be removed from the furnace and its collection system. In addition, the vent temperatures are also considerably lower than conventional furnaces. This allows the use of low temperature plastic as the vent system. The recommended material is schedule 40 PVC, DWV, ABS (or equivalent if allowed by local code). **FOAM CORE PIPING MUST NOT BE USED.**

See previous chart for proper sizing. The drain trap and related parts must be installed as shown in the illustrations located elsewhere in these instructions. Failure to follow these instructions can cause products of combustion including **CARBON MONOXIDE** to enter the building. This appliance may be horizontally vented through an exterior wall. See the illustrations located elsewhere in this manual. **IF THIS FURNACE IS INSTALLED ABOVE AN OCCUPIED OR SIMILAR AREA WHERE CONDENSATE OVERFLOW MAY BE A PROBLEM AN AUXILIARY DRAIN PAN MUST BE INSTALLED UNDER THE FURNACE WITH THE AUXILIARY DRAIN LINES ROUTED TO THE OUTDOORS TO PREVENT WATER DAMAGE CAUSED BY LEAKS.**

The vent pipes must be inspected annually.

Visually check the vent terminal and combustion air supply pipe. Clean if necessary.

Visually check for blockage of the condensate disposal system. Hoses may be disconnected to determine that proper flow is maintained. Should an obstruction be observed, it can be dislodged by forcing a stream of water through it using a device such as a garden hose.

This appliance may be vertically or horizontally vented. Horizontal venting requires a 90° long sweep elbow be installed as the vent terminal. This elbow is to be installed discharging downward and the factory supplied termination screen is to be attached. This elbow must be located no less than 12" above grade or expected snow levels. To prevent damage to the vent pipe and its terminal, the distance from the terminal to the exiting wall is to be the minimum practical distance (within 12" would be acceptable). **Vertical venting does not require a terminal.** If desired, the vent may be faced

downward to prevent water or other foreign objects from entering the vent pipe. In that case, two long radius elbows may be employed, facing downward and terminating no less than one foot (1') from the roof surface or expected snow level.

Protection From Freezing

The vent pipe and drain assembly must be properly protected from freezing particularly if it is installed in an UNHEATED SPACE. Low wattage tape heaters should be employed on the drain system. The vent pipe should be insulated using a one (1) inch thick closed foam insulation if exposed to the outdoors. For pipes located indoors or protected from the elements such as a garage, basement, etc. fiberglass with an R value of 7 or greater is acceptable.



CAUTION

DO NOT INSTALL THE VENT PIPE IN THE SAME CHASE WITH THE VENT FROM ANOTHER FUEL BURNING APPLIANCE, EXCEPT WITH A GMN, GMPN, GSUS, GSU, GSM, GSMS OR ANOTHER GMNT FURNACE MANUFACTURED BY GOODMAN.

DO NOT INSTALL THE VENT PIPE WITHIN SIX (6) INCHES OF ANOTHER FUEL BURNING APPLIANCE.

THE DRAIN TRAP MUST BE EASILY ACCESSIBLE FOR CHECKING AND/OR CLEANING. IT MUST BE MOUNTED AS SHOWN ELSEWHERE IN THESE INSTRUCTIONS.

DO NOT INSTALL THE TRAP HIGHER THAN THE VENTER BLOWER OUTLET.

DO NOT INSTALL THIS APPLIANCE IN ANY AREA WHERE FREEZING MAY OCCUR WITHOUT PROPERLY PROTECTING THE DRAIN ASSEMBLY.

DO NOT TERMINATE THE VENT UNDER A DECK, OVERHANG OR IN A POSITIVE PRESSURE AREA. THE RECIRCULATION OF VENT PRODUCTS MAY OCCUR.

CONSULT LOCAL CODES FOR SPECIAL ADDITIONAL REQUIREMENT.

THE COMBUSTION PRODUCTS IN THE FLUE GASES WILL CONDENSE. THE CONDENSATE MAY FREEZE ON THE EXTERIOR WALL AND SURROUNDING SURFACES. SOME DISCOLORATION OR ETCHING IS TO BE EXPECTED.

When selecting which exterior wall to penetrate, the following items should be taken into consideration:

1. Layout the vent system to avoid the possibility of interference with beams, poles, posts, electrical wiring, plumbing, etc.
2. When possible, the vent termination/combustion air supply pipe should not be subjected to prevailing winds.
3. The vent terminal must be located at least twelve (12) inches above grade or expected snow depth. Consideration should be given to past unusual snowfalls.
4. To protect the exterior surface from staining due to the condensate, an aluminum plate or similar material may be installed surrounding the termination. This plate should extend approximately two (2) feet around the penetration.

CONDENSATE DRAIN

This furnace is designed to remove both sensible and latent heat from the combustion products. As a result water vapor is condensed in the secondary heat exchanger. This condensate must be drained either to the outdoors or, where local code permits, to a sewage system.

In areas where floor level drains are not available, a condensate pump may be employed. This condensate pump must be constructed of corrosion resistant materials. It must also have an auxiliary switch that will shut down the furnace in the event of a pump failure or drain tube blockage.

DO NOT run the condensate drain to an outdoor drain or to an unheated area where the possibility of freezing may occur.

Note: Some locals require the condensate to be neutralized. Check local codes.

DRAIN CONNECTIONS

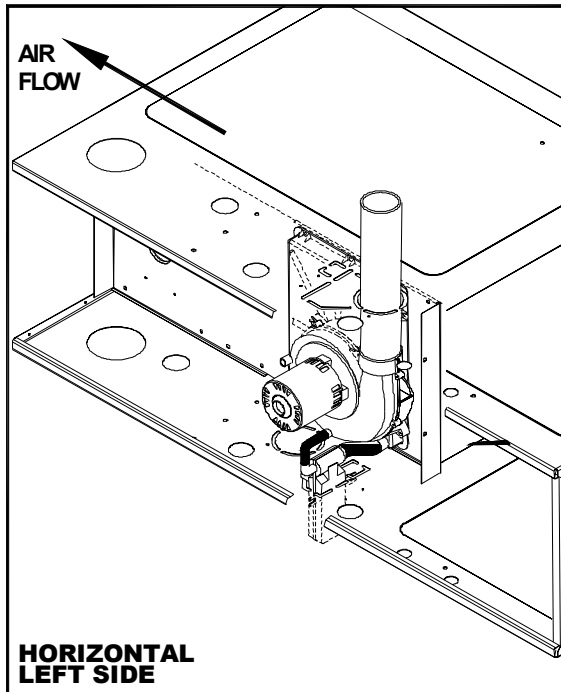
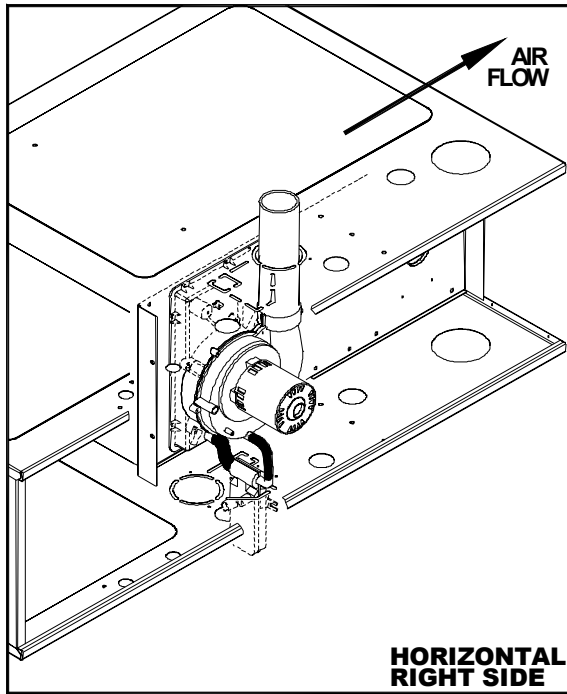

DRAIN CONNECTIONS

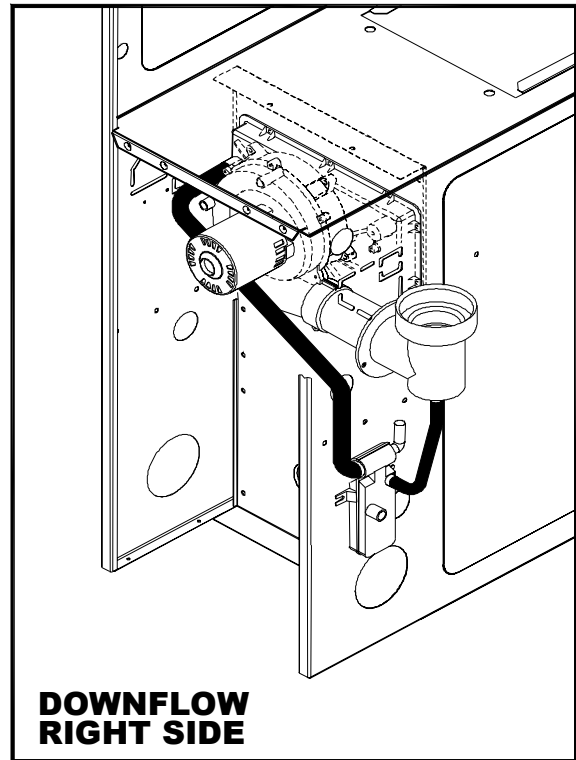
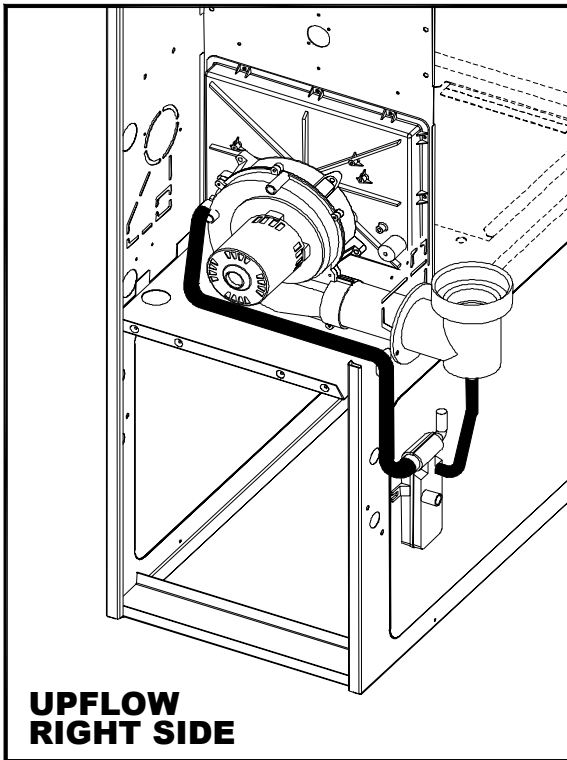
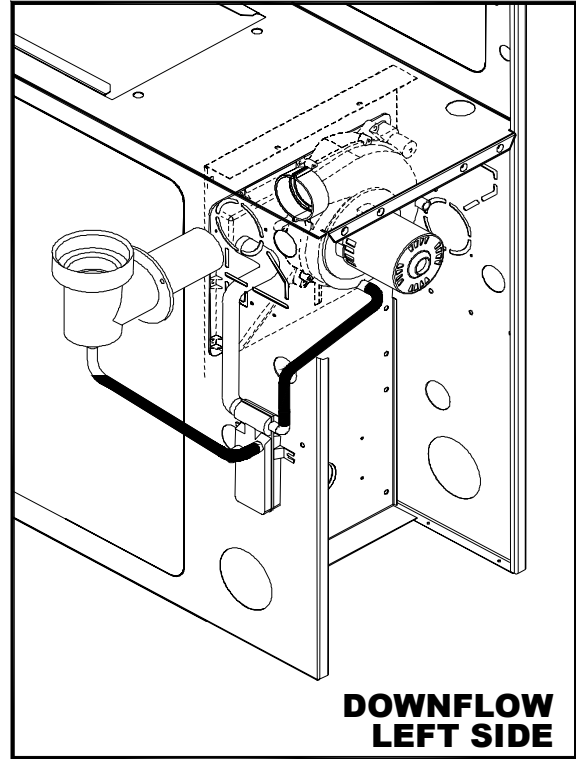
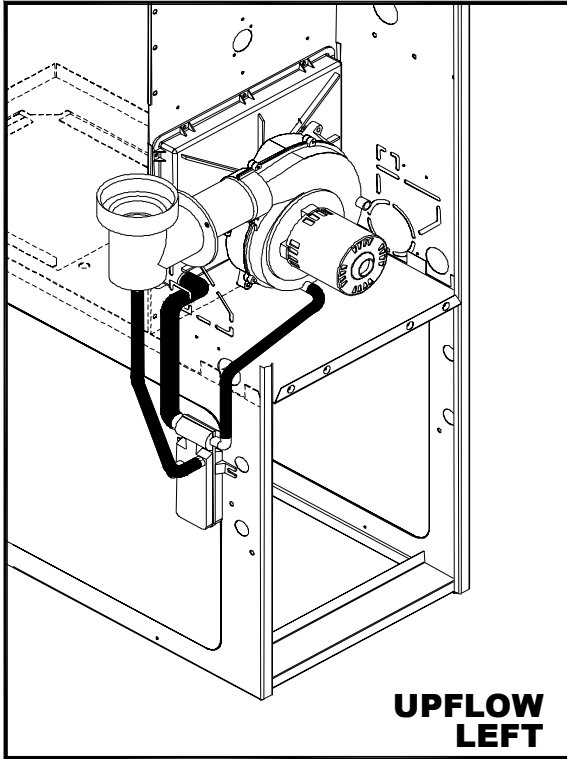

GAS PIPING & GAS PIPE CAPACITY TABLE

Check the rating plate to make certain that the gas supplied is compatible with the unit requirements. Care should be taken after the installation of this appliance that the gas control valve is not subjected to high gas supply line pressure. In making connections, avoid strains as they may cause noise and damage the controls. Always use a back-up wrench when tightening the gas supply pipe to the gas control valve. Check for leaks in the gas supply using soap bubbles or other approved methods.

NEVER USE AN OPEN FLAME TO CHECK FOR GAS LEAKS. THIS PRACTICE MAY CAUSE A FIRE, EXPLOSION, BODILY HARM OR PROPERTY DAMAGE.

Pipe joint compound must be resistant to the action of L.P. gas. When connecting the gas service to the furnace, a ground joint union and manual shutoff must be installed exterior to the furnace cabinet and located in the same room so the control assembly may be easily removed.

A 1/8" NPT plug on the supply pipe near the manual valve for the purpose of making pressure measurement should also be installed. The valve should be readily accessible for turning on or off. A capped sediment trap, sometimes called a drip leg, must be installed in the gas supply pipe as close to the furnace as possible. The sediment trap must incorporate a change of gas flow direction.

Refer to local codes or the previously mentioned publications for proper location and size of the manual shutoff and sediment trap lengths.

The gas pipe must be sized to eliminate undue pressure drop. See pipe capacity table or consult your local utility. Both the supply and manifold pressure must be measured with the furnace running using the field supplied pressure tap near the manual shut-off valve and the pressure adjusted if necessary.

All gas piping must conform to local codes, or in the absence of local codes, to the National Fuel Gas Code ANSI Z223.1 and / or CAN/CGA B149 Installation Codes.

Note: Copper tubing must not be used for natural gas installations where more than .3 grains of hydrogen sulfide per 100 standard cubic feet of gas is present. (If the quantities of hydrogen sulfide cannot be verified, do not use copper).

FOR INSTALLATIONS IN THE COMMONWEALTH OF MASSACHUSETTS SEE FUEL GAS AND PLUMBING CODE 248 CMR: APPENDIX C.

Capacity of gas pipe of different diameters and length in ft ³ /hr. with a pressure drop of 0.3" W.C. and a specific gravity of 0.60 (natural gas).						
Pipe Size*		1/2	3/4	1	1 1/4	1 1/2
Length of Pipe in Feet	10	132	278	520	1050	1600
	20	92	190	350	730	1100
	30	73	152	285	590	890
	40	63	130	245	500	760
	50	56	115	215	440	670
	60	50	105	195	400	610
	70	46	96	180	370	560
	80	43	90	170	350	530

*Nominal size of iron pipe in inches.

After the length of pipe has been determined, select the pipe size, which will provide the minimum cubic feet per

hour of gas flow for the required input of the appliance. In the case where more than one appliance utilizes the same supply pipe be sure to consider the sum of all appliances. The cubic feet of gas required for the appliances should be determined using the following formula;

$$\text{Cubic feet of gas required} = \frac{\text{Gas input of appliance (BTU/hr.)}}{\text{Heating value of gas (BTU/hr.)}}$$

The gas input of the appliance is marked on the specification plate. The heating value of the gas may be determined by contacting the gas utility or gas supplier.



CAUTION

IF THE LOCAL UTILITY PERMITS THE USE OF A FLEXIBLE GAS CONNECTOR - **ALWAYS USE A NEW FLEXIBLE CONNECTOR.** DO NOT USE FLEXIBLE GAS LINES THAT HAVE SERVICED ANOTHER APPLIANCE. AFTER A PERIOD OF TIME THESE LINES MAY BECOME BRITTLE AND CAN DEVELOP LEAKS. THE CONNECTIONS TO A FLEXIBLE GAS LINE MUST BE MADE OUTSIDE OF THE FURNACE CABINET.

CIRCULATING AIR SUPPLY AND RETURN AIR

The circulating air supply may be taken from; 1) Outside the building, 2) return ducts from several rooms, 3) central return, 4) any combination of the above.

When a cooling coil is not installed it is recommended that the supply duct have an access panel so the heat exchanger can be viewed. This panel shall be of sufficient size to permit the entrance of a light or probe to assist in the observation of the heat exchanger integrity or sampling the air stream. It should be sealed to prevent air leakage during normal operation.

Return air from one dwelling shall not be discharged into another dwelling through the heating system.

There shall be a positive separation between combustion air and return air.

Do not obtain return air from a hazardous or insanitary location or a refrigeration machinery room or any room or space having any fuel-burning appliances therein.



CAUTION

DO NOT TAKE RETURN AIR FROM BATHROOMS, KITCHENS, FURNACE ROOMS, GARAGES, UTILITY/LAUNDRY ROOMS OR COLD AREAS. IF OUTSIDE AIR IS UTILIZED, IT SHOULD NOT BE TAKEN FROM WITHIN 10 FEET OF AN APPLIANCE VENT OUTLET, A VENT OPENING OR A PLUMBING DRAINAGE SYSTEM, OR THE DISCHARGE FROM AN EXHAUST SYSTEM UNLESS THE OUTLET IS THREE (3) FEET ABOVE THE OUTSIDE AIR INLET. DO NOT TAKE RETURN AIR FROM AN AREA WHERE IT CAN PICK-UP OBJECTIONABLE ODORS, FUMES, OR FLAMMABLE VAPORS.

Note: When a combination of outdoor and indoor air is utilized the system should be designed and adjusted such that the temperature reaching the appliance will not drop below 50° F during heating operation. This will minimize the possibility of condensate forming inside the heat exchanger. When this type of system is utilized the volume of air must not be reduced.

Plenum chambers and air ducts must be installed in accordance with the Standard for the Installation of Air Conditioning and Ventilating Systems, NFPA #90A, or the Standard for the Installation of Warm Air Heating and Air Conditioning Systems, NFPA # 90B.

If installed in parallel with a cooling unit the damper or other means used to control the flow of air must be adequate to prevent chilled air from entering the furnace, and if manually operated must be equipped with means to prevent operation of the other unit unless the damper is in the full heat or cool position.

NOTE: UPON INITIAL START-UP SOME SMOKE OR AN ODOR MAY BE PRESENT. THIS IS NORMAL AND SHOULD DISAPPEAR IN A SHORT AMOUNT OF TIME. IT IS RECOMMENDED THAT WINDOWS AND DOORS BE OPENED UPON INITIAL START-UP TO VENT THIS **NON-TOXIC** SMOKE.

One of the most common causes of problems, including premature heat exchanger failure, in a forced air heating system is insufficient return air. The return air connections to the furnace should be approximately equal to the area of warm air discharge. Consult local codes for specific requirements.

All return ducts must be adequately secured to the furnace and sealed airtight. All other ductwork must be secured with approved connections and sealed airtight.

When the furnace is mounted on a platform it must be sealed air tight between the furnace and the return ductwork. The floor or platform must provide sound physical support for the furnace without cracks, gaps, sagging, etc. around the base as to provide an airtight seal between the support and the base.

Install the return air to terminate through the base under the furnace. For installations where return air ducts cannot be run under the floor, the return air supply may be taken from the side(s).

Embosses are provided on the sides of the furnace for use as a template for the ductwork connection.

Where the maximum required airflow is **1800 c.f.m.** or greater, the bottom or both sides must be utilized for return air supply. Never use the rear of the furnace for the return connection unless it is for conditions where additional return air ducts are desired.

ELECTRICAL SUPPLY CONNECTIONS

The electrical requirements are 115Volts, 60 Hz., 1 Ph. A separate supply line with a current overload device and a manual switch, where required, must be installed. Type "T" wire or equivalent with a minimum rating of 95°F (35°C) temperature rise must be run directly from the main power supply. Use copper conductors only.

Holes are provided on both sides of the furnace for electrical connection. The junction box may be moved to either side. The entry holes for supply and low voltage control wires are for use with 1/2" electrical connectors.

All electrical wiring entering the furnace must be secured to the casing with proper methods of strain relief. Solderless connectors may be used to connect wires inside the junction box for supply wires.

It is recommended that a means of shutting off the power be within sight of the furnace.

INSTALLATION OF THE ELECTRICAL SUPPLY MUST BE IN ACCORDANCE WITH LOCAL CODES. IN THE ABSENCE OF LOCAL CODES REFER TO THE NATIONAL ELECTRICAL CODE ANSI/NFPA NO. 7 (LATEST EDITION), WHICH CAN BE OBTAINED FROM THE NATIONAL FIRE PROTECTION ASSOCIATION, BATTERYMARCH PARK, QUINCY, MA 02269. IN CANADA REFER TO THE LATEST EDITION OF THE CANADIAN ELECTRICAL CODE C22.1 PART I.

CONTROL VOLTAGE CONNECTIONS

Thermostat Installation

Install the thermostat in accordance with the instructions accompanying the thermostat. Connect the thermostat wiring to the thermostat terminal block on the furnace control board. The thermostat wiring should be a minimum of 18 gauge. Adhere to recommended color code to facilitate future troubleshooting.

The thermostat should be located near the return air grille or opening. It should be approximately 5 feet from the floor level. Never locate the thermostat where it will be influenced by heat generated by hot water pipes, lamps, televisions, direct sunlight, supply air registers, etc.

Interconnecting wiring must be secured and protected from damage or disconnection. The use of solderless connectors or equivalent is recommended. The low voltage control wiring exiting the furnace is labeled "thermostat wiring".

Setting The Heat Anticipator

Following the instructions accompanying the thermostat for proper adjustment of the anticipator.

FEATURES

The integrated control board in this furnace has terminals provided for added features. These features are a 115v. Humidifier, a 24v. Humidifier, an Electronic Air Cleaner, Blower "OFF" Timing and Twinning with another furnace.

115 Volt Humidifier

The "115v HUM" terminal is located on the high voltage side of the board. It is covered with a terminal protector. See wiring below.

24 Volt Humidifier

The "HUM" lug for the operation of a 24-volt humidifier is located in the vicinity of the thermostat connections. See wiring.

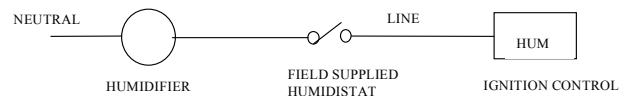

Electronic Air Cleaner

The E.A.C. terminal is located near the blower speed connections and is covered with a terminal protector. This option should be wired in conjunction with the electronic air cleaner. This feature assures the indoor blower fan is energized when there is a demand for air cleaner.

Blower Time Selection

The blower "OFF" timing is field selectable. See below for the method of changing these times.

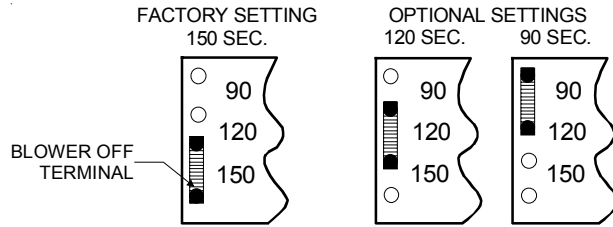

Twining

- The twin feature allows two furnaces to be connected to a single control circuit.
- A common ground **must** be provided between the units to be connected.
- The power supply **must** be obtained from the same buss bar in the circuit breaker box (each furnace **must** have a grounded, dedicated circuit).
- The control board **must** be produced by the same manufacturer.
- It is recommended that common ductwork be used.
- A wire **must** run between the "TWIN" terminals. These terminals are 3/16".

RATING THE FURNACE

This furnace is shipped from the factory equipped for use with natural gas. The instructions are for use with natural gas at altitudes up to 2,000 feet, using a heating value of 1,000 Btu/hr. Should this appliance be converted to L.P., refer to the instructions included in the factory authorized L.P. Conversion Kit (**LPT-01**). If for use at altitudes in excess of 2,000 feet refer to the instructions included in the factory authorized High Altitude Kit (**HA-02**).

It is important to check and adjust the input rate of the furnace to prevent an overfiring situation. Overfiring can cause premature heat exchanger failure. The input is controlled by the supply pressure, orifice size, manifold pressure and heating (calorific) value of the gas.

The supply pressure must be measured with this and all other gas burning appliances in operation. The supply pressure must be adjusted to the pressure range stated on the series and rating plate. Applications for altitudes in excess of 2,000 feet require an orifice change. The orifices must be selected using the table below. *The furnace derate is 4% for each 1,000 feet above sea level.* This table is based upon a heating value of approximately 1,000 Btu/ft³.

ALTITUDE	NAT. GAS ORIFICE SIZE
0 – 1,999	#45
2,000 – 2,999	#46
3,000 – 3,999	#47
4,000 – 4,999	#47
5,000 – 5,999	#47
6,000 – 7,000	#48

The input to the furnace must be checked AFTER reorificing. For altitudes above 7,000 feet refer to appropriate section of the National Fuel Gas Code, ANSI Z223.1. To calculate the input of the furnace for installations in altitudes over 2,000 feet, use the following formula;

CORRECTED INPUT = SERIES & RATING PLATE INPUT - (ALTITUDE X .04) X SERIES & RATING PLATE INPUT / 1000

Example:

Corrected input for a 100,000 Btu/hr. appliance installed at an altitude of 6,000 ft. utilizing natural gas with a heating value of 1,000 Btu/ft³ is determined by-

$$\text{Corrected Input} = 100,000 - (6,000 \times .04) \times (100,000 / 1,000)$$

$$\text{Corrected Input} = 100,000 - (240 \times 100)$$

$$\text{Corrected Input} = 100,000 - 24,000$$

$$\text{Corrected Input} = 76,000$$

Using the orifices sized as shown in the table for 6,000 feet (#48), a meter time of 48.0 seconds is measured. The actual firing rate of the furnace is

$$\text{Input} = 1,000 (\text{heating value of the gas}) \times 3600 (\text{constant}) / 48.0 (\text{meter time for } 1 \text{ ft}^3 \text{ of gas})$$

$$\text{Input} = 3,600,000 / 48.0$$

$$\text{Input} = 76,000 \text{ Btu/hr}$$

In Canada, the series and rating plate input for the furnace apply to installations up to 2,000 feet (610m) above sea level. Kit HA-02 for natural and L.P. gases is required to convert furnaces from elevations of 2,000 to 4,500 feet (610m to 1,370m). Canadian certification applies to the installations of up to 4,500 feet above sea level. Installations above 4,500 feet are subject to acceptance by the local authorities having jurisdiction.



WARNING

BEFORE ATTEMPTING ANY SERVICE OR ADJUSTMENTS - ENSURE THAT THE GAS AND ELECTRICAL SUPPLIES ARE "OFF".

TIMING THE GAS METER

Use the following method to determine the firing rate of the furnace. The supply pressure tap should be located on the field-installed piping or gas shut-off valve. The manifold pressure tap is located on the combination gas valve in the furnace and labeled "OUTLET PRESSURE TAP".

- Install a manometer graduated in tenths of an inch of water column on the supply pressure tap of the gas supply pipe.
- Remove plug at the "Manifold" pressure tap on the gas valve and install a second manometer.
- Determine the size of gas meter used.
- Shut off all other gas fired appliances with the exception of the pilots.
- Place furnace in operation.
- Check the supply pressure as shown on the series and rating plate.
- After 15 minutes of operation, time the meter with a stopwatch for 2 revolutions & divide by 2.
- Use the appropriate column in the following table to determine the furnace input.
- If necessary, adjust the manifold pressure at the gas valve by removing the regulator cap and turning the adjustment screw clockwise (**P**) to raise the pressure and counterclockwise (**Q**) to reduce the pressure. The manifold pressure must be between 3.2" W.C. and 3.8" W.C. for natural gas and 9.5" W.C. and 10.5" W.C. for L.P. (a field conversion is necessary for L.P.). The inability to maintain the proper pressure range will require reorificing. After replacing the orifices, repeat the above steps to insure that the furnace input is adjusted properly.

- Turn off gas and electrical supply, remove manometers and replace any plugs, which were removed. Use a pipe joint compound, which is suitable for use with L.P. gas.
- Restore any other appliances affected to their normal operating mode.

METER TIME IN MINUTES AND SECONDS FOR NORMAL INPUT RATING OF FURNACES EQUIPPED FOR USE WITH NATURAL GAS AT 0 - 2,000 FEET ALTITUDE.

INPUT Btu/hr	METER SIZE FT ³	HEAT VALUE 900	HEAT VALUE 1,000	HEAT VALUE 1040	HEAT VALUE 1,100
		MIN. SEC.	MIN. SEC.	MIN. SEC.	MIN. SEC.
40,000	1	1 21	1 30	1 33	1 39
	10	13 30	15 00	15 36	16 30
60,000	1	0 54	1 00	1 03	1 06
	10	9 00	10 10	10 24	11 00
80,000	1	0 41	0 45	0 47	0 50
	10	6 45	7 30	7 48	8 15
100,000	1	0 32	0 36	0 37	0 40
	10	5 24	6 00	6 14	6 36
120,000	1	0 27	0 30	0 31	0 33
	10	4 30	5 00	5 12	5 30

SPECIAL INSTRUCTIONS FOR WHITE RODGERS 36G22 GAS VALVE ADJUSTMENT

OUTLET PRESSURE REGULATOR ADJUSTMENT

These controls are shipped from the factory with the regulator set as specified on the control label.

Consult the appliance rating plate to ensure burner manifold pressure is as specified. If another outlet pressure is required, follow these steps.

36G22M Model (standard)

This has a range of adjustment of 2.5 - 5.0 inches W.C. for NATURAL gas or 7.0 - 12.0 inches W.C. for LP gas.

36G22M Model (limited adjustment)

This valve cannot be adjusted beyond reg. setting specified on the control label.

REFER to valve control label for reg. or manifold pressure setting.

1. Turn off all electrical power to the system.
2. Using a 3/32 inch hex wrench, loosen outlet pressure tap screw (located in outlet pressure boss, see fig. 1) one turn (screw need not be removed).
3. Attach a 5/16 inch hose and manometer to the outlet pressure boss of the valve (see fig. 1). Hose should overlap boss 3/8 inch.
4. Turn on system power and set thermostat to call for heat.
5. Using a leak detection solution or soap suds, check for leaks at hose connection. Bubbles forming indicate a leak. SHUT OFF GAS AND FIX ALL LEAKS IMMEDIATELY.
6. Remove regulator cover screw and turn regulator adjust screw clockwise (⤵) to increase pressure, or counterclockwise (⤴) to decrease pressure (see fig. 2). Always adjust regulator to provide the correct pressure according to the original equipment manufacturer's specifications listed on the appliance rating plate. Replace regulator cover screw and tighten securely.
7. Turn off all electrical power to the system.

8. Remove manometer hose from the outlet pressure boss.
9. Tighten outlet pressure tap screw to seal pressure port (clockwise, 13 in-lb minimum).
10. Turn on system power and set thermostat to call for heat.
11. Using a leak detection solution or soap suds, check for leaks at pressure boss screw. Bubbles forming indicate a leak. SHUT OFF GAS AND FIX ALL LEAKS IMMEDIATELY.

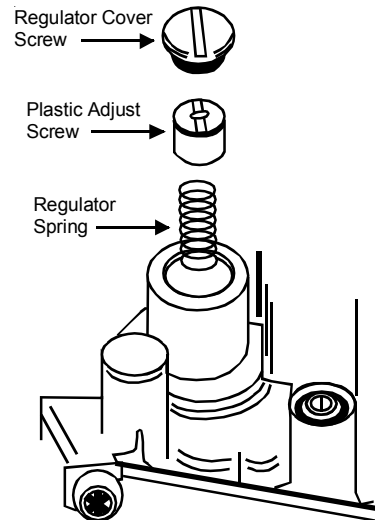
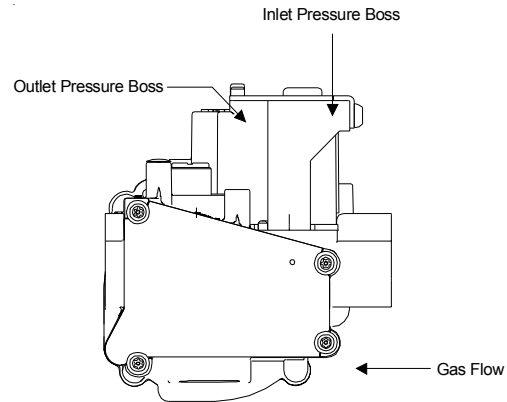

INLET PRESSURE READING



CAUTION

INLET PRESSURE TAP IS DIRECTLY CONNECTED TO GAS SUPPLY REGARDLESS OF VALVE SWITCH POSITION. FAILURE TO FOLLOW THIS PROCEDURE EXACTLY COULD RESULT IN A FIRE OR EXPLOSION HAZARD.

PROCEDURE:

INLET PRESSURE BOSS VALVE SWITCH

1. Turn valve switch to "OFF" position.
2. Shut off gas supply upstream of valve.
3. Using a 3/32 inch hex wrench, loosen inlet pressure tap screw (located in inlet pressure boss, see fig. 3) one turn (screw need not be removed).
4. Attach a 5/16 inch hose and manometer to the inlet pressure boss of the valve (see fig. 3). Hose should overlap boss 3/8 inch.

5. Turn on gas supply to valve.
6. Using a leak detection solution or soap suds, check for leaks at hose connection. Bubbles forming indicate a leak. **SHUT OFF GAS AND FIX ALL LEAKS IMMEDIATELY BEFORE PROCEEDING TO NEXT STEP.**
7. Read manometer. This reading is the system inlet pressure.
8. Shut off gas supply upstream of valve.
9. Remove manometer hose from inlet pressure boss.
10. Tighten inlet pressure tap screw to seal pressure port (clockwise, 13 in-lb minimum).
11. Using a leak detection solution or soap suds, check for leaks at pressure boss screw. Bubbles forming indicate a leak. **SHUT OFF GAS AND FIX ALL LEAKS IMMEDIATELY.**
12. Turn valve switch to "ON" position.

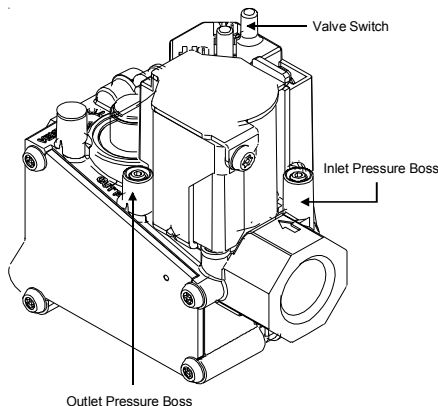

SAFETY CONTROL FUNCTIONS AND CHECK-OUT PROCEDURE

General

In most cases, the safety controls are wired in series with the "W" leg. It is imperative that these switches remain in the circuit. Never jumper, relocate (unless as noted on the furnace) or bypass any control. The safety controls must be checked for proper operation at the time of start-up of the furnace.



WARNING

SHOULD ANY SAFETY CONTROL BE ALTERED, JUMPED OR BYPASSED, A HAZARDOUS CONDITION SUCH AS FIRE OR THE POSSIBILITY OF **CARBON MONOXIDE** ENTERING THE BUILDING MAY OCCUR.

Main Limit Switch

The main limit switch is a 1/2" disc designed to shut off the burner gas should the outlet temperature exceed the maximum design outlet air temperature. This switch is not adjustable. To check the operation, block the return airflow through the unit temporarily. The limit switch should function and shut the burner gas off within a few minutes. Remove the blockage and allow the switch to cool sufficiently before reestablishing burner flames.

Vent Pressure Switch

This furnace utilizes a vent pressure switch, which prevents the furnace from operating should any portion of the vent system become restricted or a venter failure occur. To check

this switch, place the furnace in operation and remove the hose from the switch. The gas burners will extinguish. Replacing the hose will allow the furnace to operate normally.

Flame Roll-Out Switch

This furnace is equipped with multiple flame roll-out switches. These manually resettable switches are 1/2" disc type and are non-adjustable. They are designed to shut down the burner gas in the event that flames are detected outside the heat exchanger. **Should a switch function, contact a qualified service person to determine the cause of function before resetting.** To reset this switch, press the button on top of the switch after the furnace has cooled. To test the operation of the switch with the furnace in operation, place an open flame on the disc portion of the switch. The switch should function to shut down the burner gas. **Wait until the furnace has cooled sufficiently before resetting the switch.**

Flame Sensor

The ignition is provided by electronic means. The burner flames should be extinguished if the flame sensor fails to detect the presence of burner flame. To test, disconnect the flame sensor wire before placing the furnace in operation. The electronic ignition should ignite the burners. However, the burners should shut off after a few seconds of operation. Disconnect the electrical supply to the furnace, reinstall the disconnected sensor wire and reset the power supply to restore the furnace to its normal operation.

Blower Door Interlock Switch

The purpose of the switch is to disconnect electrical power to the furnace should the blower door become dislodged, removed, or not properly reinstalled after servicing. **ALLOWING THE FURNACE TO OPERATE WITHOUT THE BLOWER DOOR BEING SECURELY IN PLACE CAN CAUSE COMBUSTION PRODUCTS TO BECOME CIRCULATED THROUGHOUT THE LIVING AREA WHICH CAN CAUSE SERIOUS ILLNESS OR CARBON MONOXIDE POISONING.** To test the operation of this switch, place the furnace in operation and remove the blower access door. The burner flames will extinguish and the venter and circulating air blowers should both stop. To restore the unit to normal operation, shut off the electrical power to the unit, replace the blower access door and restore the electrical power.

Stack Over-Temperature Switch

Located on the venter blower housing, this switch is designed to shut down the burners should the circulating air blower fail or the secondary coil become blocked. To test this switch, bypass the main limit switch, disconnect the circulating air blower, and place the furnace in operation. After a short period of time this switch should function shutting down the burners.

IT IS VERY IMPORTANT TO REMOVE THE BYPASS FROM THE MAIN LIMIT SWITCH AND REPLACE THE WIRES, WHICH WERE DISCONNECTED FOR THIS TEST PRIOR TO RETURNING THE FURNACE IN NORMAL OPERATION.

Integrated Fan / Ignition Control

This furnace is equipped with a combination ignition module and fan control. An electronic device ignites the burners upon a call for heat. It also controls the venter blower and the various speed selections of the circulating air blower.

This control is located in the circulating air blower compartment. Upon a demand for heat, the venter is energized. After a short purge, the electronic ignition device is energized. The burners are ignited after a short delay and the burner flame is proven. The circulating air blower is energized at approximately 30 seconds after the burners are ignited. The circulating air blower off time is field selectable at 90, 120 or 150 seconds. THIS CONTROL IS NOT FIELD SERVICEABLE.

CIRCULATING AIR FILTERS

One of the most common causes of problems in a forced air heating system is blocked or dirty filters. Circulating air filters must be inspected monthly for dirt accumulation and replaced if necessary. Failure to maintain clean filters can cause premature heat exchanger failure. A new home may require more frequent replacement until all construction dust and dirt is removed. Circulating air filters must be installed external to the furnace cabinet.



CAUTION

BEFORE PERFORMING ANY SERVICE ON THIS FURNACE, DISCONNECT THE MAIN POWER SUPPLY.



CAUTION

DO NOT OPERATE THE FURNACE WITHOUT THE CIRCULATING AIR FILTERS IN PLACE. DUST AND DIRT IN THE AIR WILL RESTRICT THE AIR MOVEMENT OVER THE SECONDARY COIL CAUSING NUISANCE CYCLING OF SAFETY CONTROLS, WHICH MAY RESULT IN A "NO HEAT CONDITION."

TEMPERATURE RISE

The temperature difference between the outlet air and the inlet air of the furnace is known as the temperature rise. This furnace is designed to operate within the temperature rise displayed on the furnace series and rating plate. To ensure satisfactory performance, the temperature rise of the furnace must be measured and adjusted if necessary. Use the following procedure to measure and adjust the temperature rise;

- Prior to starting the furnace, visually inspect all joints and seams in the supply and return air ducts for leaks. Repair them if necessary.
- Adjust the room thermostat to obtain constant operation.
- Allow the furnace to operate for at least fifteen (15) minutes.
- With an accurate thermometer, measure the temperature at the return air grille. If a combination indoor / outdoor system is used, the temperature must be measured downstream of the connection.
- Measure the outlet air temperature at a point approximately twelve to eighteen (12 -18) inches from the supply air duct opening of the furnace. It may be necessary to measure the outlet air at several places to obtain an accurate average. NOTE: IF AN AIR CONDITIONING COIL IS INSTALLED, TAKE CARE SO AS NOT TO DAMAGE THAT COIL.
- Adjust the temperature rise by changing circulating air blower speed tap.

MOTOR LUBRICATION AND MAINTENANCE

The circulating air blower is equipped with bearings that are permanently lubricated by the motor manufacturer and require no additional lubrication. At the time of the monthly filter inspection, clean the exterior of the circulating air motor,

especially around the perimeter air holes to prevent the possibility of overheating due to an accumulation of dust or dirt on the windings and motor casing. As suggested elsewhere in these instructions, the air filters are to be kept clean. Dirty filters will restrict the airflow over the motor windings and possibly cause an overheating condition. The venter motor has bearings that are prelubricated by the motor manufacturer and require no attention.

SERVICE INSTRUCTIONS

- **DO** keep the circulating air filters clean. The heating system will operate more efficiently and economically.
- **DO** arrange drapes and furniture so that the supply air registers and return air grilles are unobstructed.
- **DO** close doors and windows. This will reduce the heat load on the system.
- **DO** avoid excessive use of bathroom and kitchen exhaust fans.
- **DO NOT** let heat generated by televisions, lamps, direct sunlight, etc. influence the thermostat operation.
- **DO NOT** use the furnace room as a storage area.
- **DO NOT** store gasoline or other flammable liquids or vapors in the vicinity of the furnace.
- **EXCLUSIVE** of the mounting platform, keep all combustible materials at least 3 feet from the Furnace.

SEQUENCE OF OPERATION

This appliance is controlled by the thermostat. Within this section, the term lockout is referenced. This lockout is a "soft" lockout, which will reset after one hour. It is the obligation of the installer to educate the user on the proper use of the thermostat and the sequence of operation in both the heating and cooling modes. It is also important that any repair or service be performed by a QUALIFIED service person, not by the user.

Heating Mode

- The furnace control checks for an open main limit (this limit is normally closed). If the limit is open, the furnace will remain inoperable until the limit is closed. During an open limit, the circulating air blower will be energized. The status light will blink four (4) times.
- The room thermostat reacts to a demand for heat.
- The control will then check to insure that the vent pressure switch is open. If, at this point, the vent pressure switch is closed, the control will blink two (2) times and will remain inoperable until this situation is corrected.
- The venter blower is energized.
- The vent pressure switch will close when it detects a pressure in excess of its setting. If the pressure switch fails to close, the status light will flash three (3) times. The sequence cannot continue until the pressure switch closes.
- After a pre-purge of about fifteen (15) seconds, the electronic ignition device will be energized.
- The flame rollout switches are then checked to assure they are in the closed position.
- After a slight delay, the gas valve will open if the flame rollout switches are closed.
- The burners will ignite and the flame sensor will detect the presence of flame. The ignition device will deenergize. If the sensor does not detect the burner flame, the gas valve will close and the ignition cycle will be repeated for a total of three attempts. If, after the third attempt, the presence of flame is not detected, the furnace will go into a lockout condition for one (1) hour. It will then repeat the ignition cycle. This one (1) hour lockout and retry will occur indefinitely.

- Thirty (30) seconds after the main valve is energized the circulating air blower will be activated.
- The furnace will remain in operation until the demand for heat is satisfied.
- Once the demand is satisfied the venter will shut off, and the circulating air blower will shut off after the field selectable time off is attained.
- The furnace will remain dormant until the next demand for heat.

Cooling Mode

- The control checks for an open limit. If an open limit is detected, the furnace will remain inoperable until the condition is corrected. During an open limit condition, the circulating air blower will be energized. The status light will blink four (4) times.
- A demand for cooling is initiated.
- The condenser contactor will close.
- After approximately five (5) seconds, the circulating air blower will start on the cooling speed.
- After the room thermostat is satisfied, the condenser contactor will open.
- The circulating air blower will remain in operation for approximately sixty (60) seconds.

REMOVING AN EXISTING APPLIANCE

When replacing an existing appliance, the resulting installation must comply with all local codes, or in the absence of local codes, to the National Fuel Gas Codes ANSI Z223.1 and/or CAN/CGA B149 Installation Codes as well as these installation instructions.

If the installation of this GMNT furnace requires that an existing appliance be removed from a venting system, which still serves another gas, fired appliance, this may require that the existing vent be re-sized. The following steps shall be performed with each appliance connected to the venting system placed in operation while any other appliance connected to the venting system are not in operation;

- Sealing unused openings in the venting system;
- Inspect the venting system for proper size and horizontal pitch, as required in the National Fuel Gas Code, ANSI Z223.1 or the CAN/CGA B149 Installation Codes and these instructions. Determine that there is no blockage or restriction, leakage, corrosion and other deficiencies, which could cause an unsafe condition;
- In so far as practical, close all building doors and windows and all doors between the space in which the appliance(s) connected to the venting system are located and other spaces in the building. Turn on clothes dryers and any other appliance not connected to the venting system. Turn on any exhaust fans such as range hoods and bathroom exhausts, so they shall operate at their maximum speed. DO NOT operate a summer exhaust fan (whole house fan). Close fireplace dampers;
- Follow lighting instructions. Place the appliance being inspected in operation. Adjust the thermostat so the appliance shall operate continuously;
- Test for draft hood equipped appliance spillage at the relief opening after five (5) minutes of burner operation. Use the flame of a match or candle;

- After it has been determined that each appliance connected to the venting system properly vents when tested as outlined above, return all doors, windows, exhaust fans, fireplace dampers and any other gas-burning appliance back to their previous condition of use;
- If improper venting is observed during any of the above tests, the venting system must be corrected.

INSPECTING AND CLEANING THE HEAT EXCHANGER



CAUTION

LABEL ALL WIRES PRIOR TO DISCONNECTION WHEN SERVICING CONTROLS. WIRING ERRORS CAN CAUSE DANGEROUS AND IMPROPER OPERATION. VERIFY PROPER OPERATION AFTER SERVICING.

It is the obligation of the installer to advise the user to have the furnace inspected and cleaned annually. To clean the heat exchanger, perform the following:

- Adjust the room thermostat to its lowest setting.
- Turn off the gas and electric supply to the furnace.
- Remove the control access door.
- Open the gas supply union.
- Disconnect the gas supply line attached to the gas valve.
- Remove the wires connected to the gas valve.
- Remove the burner box assembly. Care must be exercised to avoid damage to the igniter.
- Inshot burners should not require cleaning. However, if they exhibit signs of corrosion they can be cleaned by brushing with a stiff wire brush.
- Remove the vent from the furnace venter blower.
- Remove the venter blower and collector box.
- With a stiff wire brush on a flexible handle, remove any loose scale from the heat exchanger at both the flue and burner openings.
- Use a 1/2" diameter brush to remove any deposits in the secondary heat exchanger.
- With a vacuum, remove any loose scale dislodged and any additional debris found in the heat exchanger.
- Visually inspect the heat exchanger cells for any cracks or openings using a bright light.
- **If any failures are discovered, it is important to disable the furnace and notify the user to ensure that it remains inoperable until repairs are implemented.**
- Reassemble the furnace in the reverse order. **Note:** No additional screws or wires are supplied with this product. All components must be reassembled to avoid an unsafe condition.
- Reconnect gas supply and check for leaks using a soap solution. If a flexible gas line is used, examine it for cracks or weakness. Replace if necessary.
- Restore electrical power.
- Follow the lighting instructions to place the furnace into operation.

Note: It is important to use a pipe joint compound that is resistant to the effects of L.P. gas.

LIGHTING INSTRUCTIONS

FOR YOUR SAFETY READ BEFORE OPERATING



WARNING



If you do not follow these instructions exactly, a fire or explosion may result causing property damage, personal injury or loss of life.

A. This appliance does not have a pilot. It is equipped with an ignition device which automatically lights the burners. Do not try to light the burners by hand.

B. BEFORE OPERATING smell around the appliance area for gas. Be sure to smell next to the floor because some gas is heavier than air and will settle on the floor.

WHAT TO DO IF YOU SMELL GAS

- Do not try to light any appliance.
- Do not touch any electric switch; do not use any telephone in your building.
- Immediately call your supplier from a neighbor's phone. Follow the gas suppliers instructions.

◦ If you cannot reach your gas supplier, call the fire department.

C. Use only your hand to move the gas control switch or knob. Never use tools. If the gas control switch or knob will not operate, don't try to repair it, call a qualified service technician. Force or attempted repair may result in a fire or explosion.

D. Do not use this appliance if any part has been under water. Immediately call a qualified service technician to inspect the appliance and to replace any part of the control system and any gas control which has been under water.

WARNING: Improper installation, adjustment, service or maintenance can cause injury or property damage. Refer to the user's information manual provided with this furnace. For assistance or additional information consult a qualified installer, service agency or the gas supplier.

This furnace must be installed in accordance with the manufacturers instructions and local codes. In the absence of local codes, follow the National Fuel Gas Code, ANSI Z223.1.

OPERATING INSTRUCTIONS

1. STOP! Read the safety information above on this label.
2. Set the thermostat to lowest setting.
3. Turn off all electric power to the appliance.
4. This appliance is equipped with an automatic ignition system which automatically lights the burners. Do not try to light the burners by hand.
5. Remove control access panel.
6. Move the gas control switch or knob to "OFF".

7. Wait five (5) minutes to clear out any gas. If you then smell gas, STOP! Follow "B" in the safety information above on this label. If you don't smell gas, go to the next step.
8. Move the gas control switch or knob to "ON".
9. Replace control access panel.
10. Turn on all electric power to the appliance.
11. Set the thermostat to the desired setting.
12. If the appliance will not operate, follow the instructions "To Turn Off Gas To Appliance" and call your service technician or gas supplier.

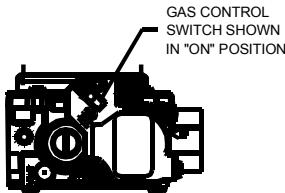

GAS CONTROL SWITCH SHOWN IN "ON" POSITION

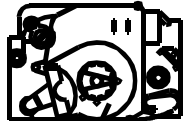

GAS CONTROL KNOB

GAS CONTROL SWITCH SHOWN IN "ON" POSITION

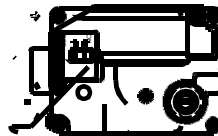

For indoor installation.

PGB & PGJ
For outdoor installation only.

WARNING: If not installed, operated and maintained in accordance with the manufacturer's instructions, this product could expose you to substances in fuel combustion which can cause death or serious illness and which are known to the State of California to cause cancer, birth defects or other reproductive harm. This product contains fiberglass insulation. Fiberglass insulation contains a chemical known by the State of California to cause cancer.

TO TURN OFF GAS TO APPLIANCE

1. Set the thermostat to its lowest setting.
2. Turn off all electric power to the appliance if service is to be performed.
3. Remove control access panel.
4. Move the gas control switch or knob to "OFF". Do not force.
5. Replace control access panel.

FOR YOUR SAFETY

Do not store or use gasoline or other flammable vapors and liquids in the vicinity of this or any other appliance.

B14933-239

WIRING DIAGRAM

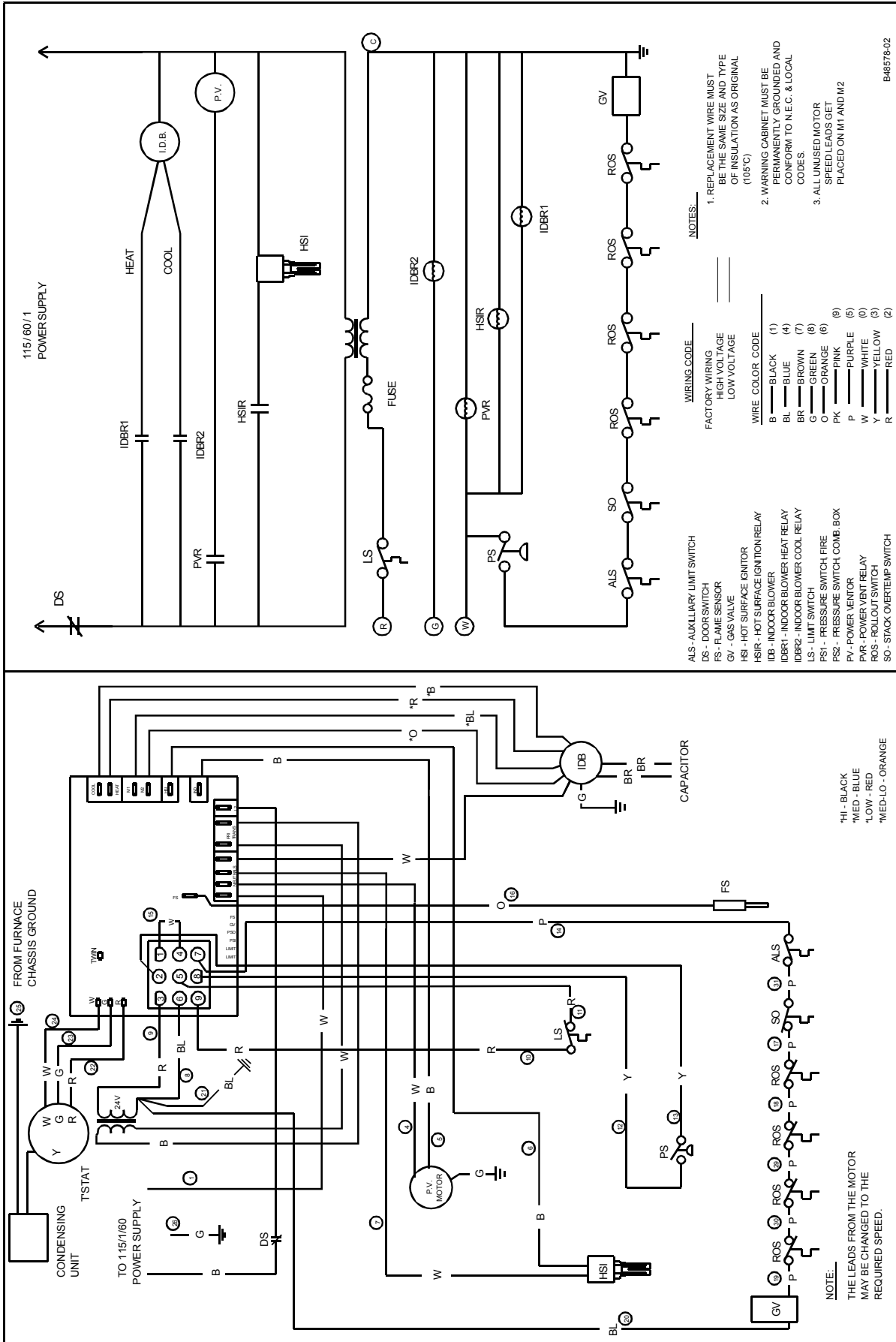

B48578-02

Quality Makes the Difference!

All of our systems are designed and manufactured with the same high quality standards regardless of size or efficiency. We have designed these units to significantly reduce the most frequent causes of product failure. They are simple to service and forgiving to operate. We use quality materials and components. Finally, every unit is run tested before it leaves the factory. That's why we know. . . There's No Better Quality.

Visit our web site at www.goodmanmfg.com for information on:

- Goodman products
- Warranties
- Customer Services
- Parts
- Contractor Programs and Training
- Financing Options