

TECHNICAL GUIDE

SINGLE PACKAGE COOLING UNITS

ACP024 THRU 060
2 THRU 5 TON (13 SEER)

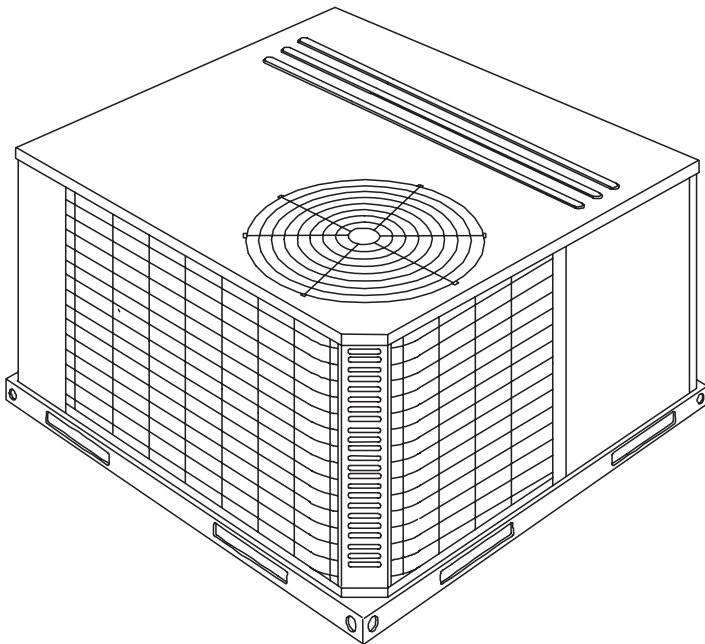

DESCRIPTION

These packaged cooling air conditioners are designed for outdoor installation. Only utility and duct connections are required at the point of installation.

Field-installed electric heater accessories are available to provide electric heat combined with electric cooling.

STANDARD FEATURES / BENEFITS

OPERATING EFFICIENCY - All ACP units provide high operating efficiencies and have a SEER up to 13.

ON SITE FLEXIBILITY - All model sizes share a common, compact design cabinet with a single footprint. The installer has the flexibility of setting one curb and placing the proper tonnage unit on that curb after the internal load has been determined. Field convertible duct connections from side shot to down shot allows the installer to have greater flexibility and needs to carry less inventory.

LOWER INSTALLATION COST - Installation time and costs are reduced by easy power and control wiring connections. The small base dimension means less space is required on the ground or roof, plus, the installer can fit this unit between the wheel wells of a full size pick-up truck. All models are well under 500 pounds.

All units are completely wired, charged with R-22 and tested prior to shipment. Unique test stations using a new state of the art computerized process system are used to insure product quality. Refrigerant charge, and component part numbers are verified via computers at installation. Vital run test statistics such as system pressure, motor currents, air velocity and temperature and unit vibration are monitored and recorded by the system to insure unit performance.

Equal size, side supply and return duct connections allows easy hook-up of ducts to match low crawl spaces without transition pieces.



ISO 9001
Certified Quality
Management System

TABLE OF CONTENTS

DESCRIPTION1
STANDARD FEATURES / BENEFITS1
FIELD-INSTALLED ACCESSORIES3
TYPICAL APPLICATIONS24
MECHANICAL SPECIFICATIONS29

LIST OF FIGURES

<u>Fig. #</u>	<u>Pg. #</u>
1 UNIT CUTAWAY.....	4
2 TYPICAL FIELD WIRING DIAGRAM.....	19
3 UNIT DIMENSIONS.....	22
4 CENTER OF GRAVITY.....	23
5 TYPICAL SLAB ON GROUND INSTALLATION.....	24
6 TYPICAL ROOF CURB INSTALLATION.....	24
7 ROOF CURB DIMENSIONS (8" ROOF CURB ALSO AVAILABLE).....	25
8 ROOF CURB APPLICATION.....	25
9 TYPICAL WIRING DIAGRAM (208/230-1-60 POWER SUPPLY) ACP MODELS.....	26
10 TYPICAL WIRING DIAGRAM (208/230-3-60 POWER SUPPLY) ACP MODELS.....	27
11 TYPICAL WIRING DIAGRAM (460-3-60 POWER SUPPLY) ACP MODELS.....	28

LIST OF TABLES

<u>Tbl. #</u>		<u>Pg. #</u>
1	PHYSICAL DATA.....	5
2	RATINGS - ARI.....	5
3	COOLING CAPACITIES - 2 TON (ACP024).....	6
4	COOLING CAPACITIES - 2-1/2 TON (ACP030).....	8
5	COOLING CAPACITIES - 3 TON (ACP036).....	10
6	COOLING CAPACITIES - 3-1/2 TON (ACP042).....	12
7	COOLING CAPACITIES - 4 TON (ACP048).....	14
8	COOLING CAPACITIES - 5 TON (ACP060).....	16
9	SIDE AND BOTTOM SUPPLY AIR BLOWER PERFORMANCE.....	17
10	ADDITIONAL STATIC RESISTANCE.....	18
11	ACP024-060 ELECTRICAL DATA / ELECTRIC HEAT.....	20
12	UNIT WEIGHTS.....	23
13	CLEARANCES.....	23

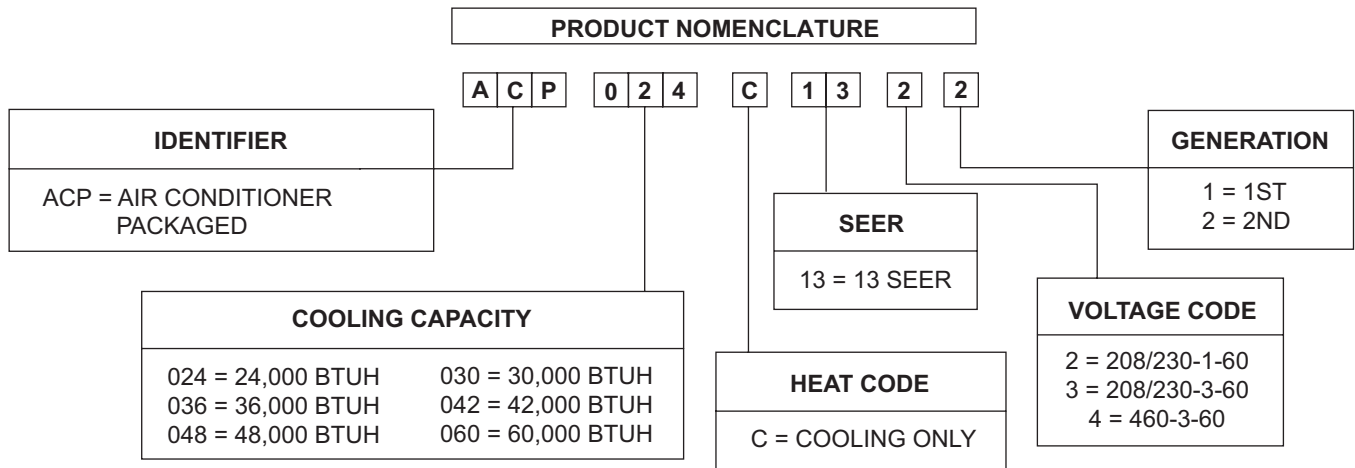

DESCRIPTION (CONTINUED)

UTILITY CONNECTIONS MADE EASY - Electrical utility knockouts are provided through the bottom as well as the side of the unit. Utility connections can be made quickly and with a minimum amount of field labor. A field supplied and field installed electrical disconnect switch must be installed.

CONVERTIBLE AIRFLOW DESIGN - The bottom duct openings are covered when they leave the factory ready to be used for a side supply / side return application. If a bottom supply / bottom return application is desired, you simply remove the two panels from the bottom of the unit and place them in the side supply / side return duct openings. No panel cutting is required and no accessory panel is necessary. Convertible airflow design allows maximum field flexibility and minimum inventory.

CONDENSATE PAN - A non-corrosive, long-lasting, water-tight pan is positioned below the evaporator coil to collect and drain all condensate. Less collection of stagnate condensate will build-up. The condensate pan conforms to ASHRAE 62-89 standards (Ventilation for Acceptable Indoor Air Quality).

CONDENSATE DRAIN - The heavy duty, inch NPTI copper connection is more tolerable during installation and is more durable over time. The connection is rigidly mounted to assure proper fit and leak tight seal.

DURABLE FINISH - With a heavy duty cabinet made of powder-painted, galvanized steel the neutral color blends into surrounding areas. The powder paint, provides a better paint to steel bond, which resists corrosion and rust creep. The special primer formulas and glossy earth tone finish insure less fading when exposed to sunlight and offers a more attractive on site appearance. This paint finish exceeds ASTM-B117 standards for 1000 hours salt spray rating, the highest in the industry.

FULL PERIMETER BASE RAILS - The easily removable base rails provide a solid foundation for the entire unit and protects the unit during shipment. The rails provide fork lift access from all sides, and rigging holes are also provided so that an overhead crane can be used to place the units on a roof. On applications when the unit is placed on a pad, the base will keep the unit off the pad to deter corrosion. On applications where height is limited, the inch high base rails may be removed on location.

MORE ATTRACTIVE APPEARANCE - A single piece "Water Shed" top cover containing a top discharge condenser fan arrangement requires less square footage on installation and provides a wider variety of installations. The one piece design adds greater water integrity. Rounded corners with water drip edges add to the attractive appearance. The cabinet panels have a non-fibrous insulation that does not add insulation fibers into conditioned area.

TOP DISCHARGE - The top discharge condenser fan does not disrupt neighboring areas and does not dry-out vegetation surrounding the unit. The warm air from the top mounted fan is blown up away from the structure and any landscaping. This allows compact location on multi-unit applications.

CONDENSER COIL GRILLE - A multi-piece totally enclosed, rigidly mounted condenser coil grille provides protection from objects and personal after installation and provides protection during transit and installation.

LOW OPERATING SOUND LEVEL - The upward air flow carries the normal operating noise up and away from the living area. The rigid top panel effectively isolates any motor sound. Isolator mounted compressor and the rippled fins of the condenser coil muffle the normal fan motor and compressor operating sounds. The unique formed base pan also aids in sound alterations with it's "Super-Structure" design. This design strategically places embossments in the pan for optimum strength and rigidity.

FAN SYSTEM - All models operate over a wide range of design conditions with a 5 speed direct drive indoor blower motor. These units easily match all types of applications and provide greater on site flexibility to match comfort requirements.

SIMPLE CONTROL CIRCUIT - A low voltage printed circuit board contains a low voltage terminal strip. The electrical control box is not located in the compressor compartment. All wiring internal to the unit is color/number coded.

PROTECTED COMPRESSOR - The compressor is internally protected against high pressure and temperature. This is accomplished by the simultaneous operation of high pressure relief valve and a temperature sensor which protect the compressor if undesirable operating conditions occur.

EXCLUSIVE COIL DESIGN - Grooved copper tubes and enhanced aluminum fin construction improves heat transfer for maximum efficiency and durability.

LOW MAINTENANCE - Long life, permanently lubricated condenser and evaporator fan motor bearings need no annual maintenance adding greater reliability to the unit. Blower assembly can be easily removed for cleaning by the unique "Slip- Track" slide-out blower assembly.

SECURED SERVICE ACCESS PORTS - Protected, externally mounted, re-usable service access ports are provided on both the high and low lines for ease of evacuating and charging the system. No final field mounting required.

EASY SERVICE ACCESS - A large, single panel covers the electrical controls and makes servicing easy. The blower compartment has an additional large panel with a built-in handle tab. Removing this panel will allow the blower assembly to slide-out for easy removal for maintenance and ease of trouble shooting.

REPLACEMENT PARTS - The installer has no need to carry an inventory of unique parts or needs special training to replace any of the components parts for these units. All are easily obtained from Source 1 or other part houses.

FIELD-INSTALLED ACCESSORIES

ECONOMIZER DOWN DISCHARGE / SUPPLY KIT - Modulating integrated economizer provides simultaneous operation between the mechanical cooling and economizer

operation. Independent blade design insures proper control and less than 1% leak rate. Includes hood and mesh bird screen filter integrated into the hood, dry bulb sensor and relief damper. Separate field accessories of single enthalpy and dual enthalpy are also available.

SINGLE ENTHALPY SENSOR - Sensor replaces dry bulb sensor standard in economizer kit. Provides improved economizer operation by sensing the dry bulb temperature from outdoors plus the enthalpy content of the outdoor air.

DUAL ENTHALPY SENSOR - Additional sensor to single enthalpy sensor. Sensor senses both the return air temperature dry bulb and humidity in conjunction with the single enthalpy to determine the most economical mix. Single Enthalpy sensor also required.

UPGRADE SAFETY PACKAGE - Contains screw in type High pressure, Low Pressure/Loss of Charge switch, freeze protection switch and lockout relay. Switches are placed onto existing scharder ports located in the unit by furnished adapters. When abnormal conditions are sensed through the pressure switches, the unit will lock out preventing any further operation until reset or problem is corrected. Package agency approved.

HAIL GUARD KIT - Kit contains protected grilles made of expanded aluminum grilles with full perimeter inch frame. Sloped hoods are also included to assure maximum protection.

ANTI SHORT CYCLE TIMER - Automatically prevents the compressor from restarting for 5 minutes after cycled off. Not required if Thermostat 2ET07700224 and 2ET04700224 are used.

FILTER / FRAME KIT (Single Phase only) - Kit contains the necessary hardware to field install return air filters into the base unit. Pre-cut filter racks and appropriate cleanable standard size filters are shipped in one kit. (1" filter is supplied) This kit is available for single phase horizontal or vertical duct application only. Standard in all 3 Phase models.

MOTORIZED FRESH AIR DAMPER - Designed for duct mounted side supply/return and unit mounted down supply/return applications. Damper capable of providing 0% thru 50% of outdoor air (field supplied). Closes on power loss, includes hood and screen assembly.

RECTANGLE TO ROUND ADAPTERS - Kit includes one supply and one return air rectangle to round duct adapter. Adapters are preformed and designed to fit over current duct openings on the base unit. Transition is from 15" square to 14" round.

ROOF CURBS - NRCA approved curbs provide proper fit to base unit for rooftop installations. Curbs are designed to be assembled through hinge pins in each corner. Kit also provides seal strip to assure a water tight seal. 8 and 14 inch high roof curbs are available.

MANUAL OUTDOOR DAMPER - Provides 0% thru 50% outdoor air capability (field adjustable). Designed for duct mounted side supply/return applications. Includes hood and screen assembly.

WALL THERMOSTAT - The units are designed to operate with 24-volt electronic and electro-mechanical thermostats. All units can operate with single stage heat / single stage cool thermostats - with or without the economizer.

LOW AMBIENT KIT - Kit provides necessary hardware to convert unit to operate in cooling cycle down to 0° F. Standard unit operation 45° F.

TRANSFORMER KIT - Kit provides necessary hardware to provide single phase models from factory furnished 40 VA transformer capability to 75 VA transformer capability.

ELECTRIC HEATERS - Each heater package provides easy installation of electric heat strips. Slide in design with plug in harness and agency approved. Heaters are available from 5.0 KW sizes and are designed for single point connection.

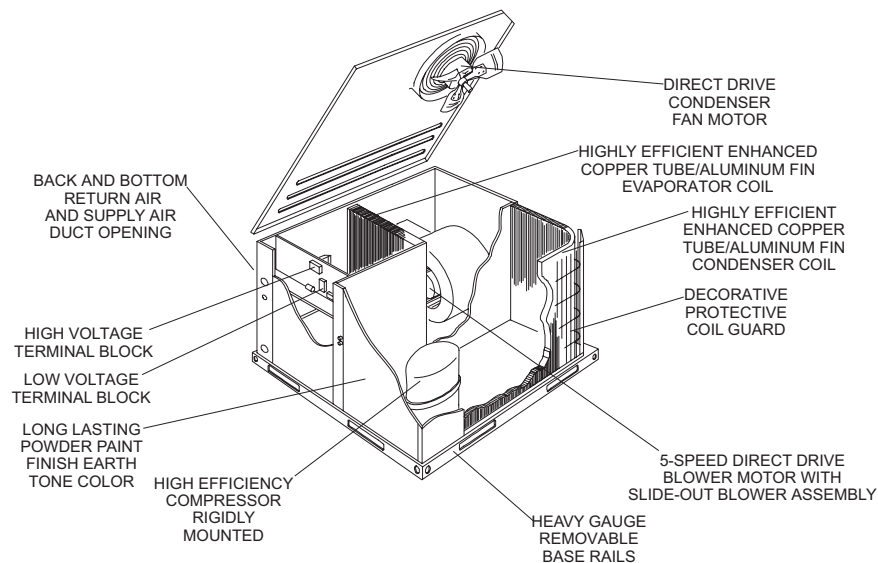

FIGURE 1 - UNIT CUTAWAY

TABLE 1: PHYSICAL DATA

MODELS		ACP					
		024	030	036	042	048	060
EVAPORATOR BLOWER	CENTRIFUGAL BLOWER (Dia. x Wd. in.)	10 x 8	10 x 8	10 x 8	11 x 10	11 x 10	11 x 10
	FAN MOTOR HP	½	½	½	¾	¾	1
EVAPORATOR COIL	ROWS DEEP	2	2	3	3	3	3
	FINS PER INCH	15	15	13	16	16	16
	FACE AREA (Sq. Ft.)	4.38	4.38	4.38	4.38	5.63	5.63
CONDENSER FAN	PROPELLER DIA. (in.)	22	22	22	22	22	22
	FAN MOTOR HP	¼	¼	¼	¼	¼	½
	NOM. CFM TOTAL	1,800	1,800	1,800	2,400	3,000	3,000
CONDENSER COIL	ROWS DEEP	1	1	1	1	1	2
	FINS PER INCH	20	20	20	20	20	20
	FACE AREA (Sq. Ft.)	12.9	12.9	12.9	12.9	16.4	16.4
CHARGE	REFRIGERANT 22 (lbs./oz.)	4/10	5/9	5/0	4/12	6/0	10/8
FILTER	FACE AREA (Sq. Ft.) / Qty. / Size	2.14 / 1 / 14" x 22"					
COMPRESSOR	HERMETIC, QTY. = 1 (Type)	Recip.	Rotary	Scroll	Scroll	Scroll	Scroll

TABLE 2: RATINGS - ARI

Model ACP	Cooling ¹ Capacity 80/67-95 °F		Sound Rating ² (decibels)	Electric Heat Nom. Capacity KW (single phase)	Electric Heat Nom. Capacity KW (three phase)
	MBH	SEER			
024	24.0	13.00	80	5.0, 7.5, 10.0	N / A
030	29.2	13.00	82	5.0, 7.5, 10.0, 15.0	N / A
036	35.0	13.00	75	5.0, 7.5, 10.0, 15.0	10.0, 15.0
042	42.0	13.00	77	5.0, 7.5, 10.0, 15.0	10.0, 15.0
048	46.0	13.00	82	10.0, 15.0, 20.0, 25.0	10.0, 15.0, 20.0, 25.0
060	58.0	13.00	82	10.0, 15.0, 20.0, 25.0	10.0, 15.0, 20.0, 25.0

1. Certified in accordance with the Unitary Small Equipment certification program, which is based on ARI Standard 210/240.
2. Rated in accordance with ARI Standard 270.

SEER = Seasonal Energy Efficiency Ratio - the total cooling output in BTU's during a normal annual usage period for cooling divided by the total electric power input in watt-hours during the same period.

TABLE 3: COOLING CAPACITIES - 2 TON (ACP024)

Air on Evaporator Coil		Temperature of Air on Condenser Coil															
CFM	WB (°F)	Total Capacity ¹ (MBh)	Total Input (kW) ²	Sensible Capacity (MBh)						Total Capacity ¹ (MBh)	Total Input (kW) ²	Sensible Capacity (MBh)					
				Return Dry Bulb (°F)								Return Dry Bulb (°F)					
				90	85	80	75	70	65			90	85	80	75	70	65
				75°F						85°F							
600	77	27.1	1.7	12.1	10.0	7.8	-	-	-	26.7	1.9	12.2	9.8	7.5	-	-	-
	72	26.8	1.7	16.7	14.6	12.4	10.3	-	-	25.8	1.9	16.5	14.2	11.8	9.5	-	-
	67	26.4	1.7	21.3	19.2	17.0	14.9	12.7	-	24.9	1.9	20.9	18.5	16.2	13.8	11.5	-
	62	25.5	1.7	24.5	22.9	20.8	18.6	16.5	14.3	23.8	1.9	22.7	21.5	19.1	16.8	14.4	12.1
	57	24.5	1.7	24.5	24.5	24.5	20.8	18.7	16.5	22.7	1.9	22.7	22.7	20.9	18.5	16.2	13.8
700	77	27.2	1.7	12.0	10.4	8.1	-	-	-	26.9	1.9	13.3	10.5	7.9	-	-	-
	72	26.9	1.7	17.6	15.2	12.9	10.6	-	-	26.0	1.9	17.6	15.0	12.4	9.9	-	-
	67	26.6	1.7	22.8	20.0	17.7	15.4	13.0	-	25.1	1.9	22.0	19.6	17.0	14.4	11.9	-
	62	25.6	1.7	24.7	23.4	21.6	19.5	17.0	14.6	24.0	1.9	22.9	22.3	20.1	17.5	14.9	12.4
	57	24.7	1.7	24.7	24.7	24.7	21.8	19.2	16.9	22.9	1.9	22.9	22.9	22.0	19.4	16.8	14.2
800	77	27.3	1.7	11.9	10.9	8.4	-	-	-	27.1	2.0	14.4	11.1	8.3	-	-	-
	72	27.0	1.7	18.4	15.9	13.4	10.9	-	-	26.2	1.9	18.7	15.9	13.1	10.2	-	-
	67	26.7	1.7	24.8	20.9	18.4	15.9	13.4	-	25.3	1.9	23.1	20.7	17.9	15.1	12.2	-
	62	25.7	1.7	24.8	24.8	22.4	20.3	17.4	14.9	24.2	1.9	23.1	23.1	21.1	18.3	15.5	12.6
	57	24.8	1.7	24.8	24.8	24.8	22.7	19.8	17.3	23.1	1.9	23.1	23.1	23.1	20.3	17.4	14.6
900	72	27.1	1.8	19.0	16.4	13.9	11.3	-	-	26.4	2.0	19.7	16.7	13.7	10.7	-	-
	67	26.8	1.8	24.9	21.9	19.0	16.5	13.9	-	25.5	1.9	23.2	21.8	18.8	15.8	12.8	-
	62	25.8	1.8	24.9	24.9	23.5	21.2	18.4	15.8	24.4	1.9	23.2	23.2	22.2	19.2	16.2	13.2
	57	24.9	1.8	24.9	24.9	24.8	22.5	19.8	17.2	23.2	1.9	23.2	23.2	23.2	20.3	17.3	14.3
	72	27.2	1.8	19.6	17.0	14.4	11.7	-	-	26.6	2.0	20.7	17.5	14.4	11.2	-	-
1000	67	26.9	1.8	25.0	23.8	19.7	17.1	14.4	-	25.7	2.0	23.4	22.8	19.7	16.5	13.3	-
	62	25.9	1.8	25.0	25.0	24.6	22.0	19.4	16.7	24.5	1.9	23.4	23.4	23.2	20.1	16.9	13.8
	57	25.0	1.8	25.0	25.0	25.0	22.3	19.7	17.1	23.4	1.9	23.4	23.4	23.4	20.3	17.1	14.0
					95°F						105°F						
	600	77	26.3	2.1	12.2	9.7	7.1	-	-	-	24.6	2.3	11.8	9.2	6.5	-	-
72		24.9	2.1	16.3	13.8	11.2	8.7	-	-	22.6	2.3	15.7	13.0	10.4	7.8	-	-
67		23.4	2.0	20.4	17.9	15.3	12.8	10.2	-	20.6	2.2	18.7	16.9	14.3	11.6	9.0	-
62		22.2	2.0	20.9	20.0	17.4	14.9	12.4	9.8	19.8	2.2	19.0	18.5	15.8	13.2	10.6	7.9
57		20.9	2.0	20.9	20.9	18.8	16.3	13.7	11.2	19.0	2.1	19.0	19.0	16.9	14.3	11.7	9.1
700	77	26.6	2.2	14.5	10.5	7.6	-	-	-	25.0	2.4	14.5	10.4	7.0	-	-	-
	72	25.1	2.1	17.7	14.8	12.0	9.1	-	-	23.0	2.3	17.0	14.2	11.2	8.2	-	-
	67	23.7	2.1	21.2	19.2	16.4	13.5	10.7	-	21.0	2.2	19.3	18.0	15.4	12.4	9.4	-
	62	22.4	2.0	21.2	21.2	18.6	15.6	12.9	10.1	20.1	2.2	19.3	19.0	17.1	14.0	11.1	8.1
	57	21.2	2.0	21.2	21.2	20.1	17.1	14.4	11.5	19.3	2.2	19.3	19.3	18.2	15.2	12.3	9.3
800	77	26.9	2.2	16.8	11.3	8.1	-	-	-	25.4	2.4	17.2	11.6	7.6	-	-	-
	72	25.4	2.1	19.1	15.9	12.8	9.6	-	-	23.3	2.3	18.4	15.4	12.0	8.7	-	-
	67	23.9	2.1	21.4	20.6	17.4	14.3	11.1	-	21.3	2.2	19.6	19.1	16.5	13.1	9.8	-
	62	22.7	2.1	21.4	21.4	19.8	16.3	13.5	10.3	20.4	2.2	19.6	19.6	18.3	14.7	11.6	8.2
	57	21.4	2.0	21.4	21.4	21.4	17.9	15.1	11.9	19.6	2.2	19.6	19.6	19.6	16.0	12.8	9.5
900	72	25.7	2.1	20.4	17.0	13.6	10.1	-	-	23.7	2.3	19.9	16.5	12.9	9.2	-	-
	67	24.2	2.1	21.6	21.6	18.5	15.1	11.7	-	21.6	2.2	19.9	19.9	17.6	14.0	10.3	-
	62	22.9	2.1	21.6	21.6	20.8	17.2	14.0	10.6	20.7	2.2	19.9	19.9	19.2	15.4	11.9	8.2
	57	21.6	2.1	21.6	21.6	21.6	18.0	14.8	11.4	19.9	2.2	19.9	19.9	19.9	16.1	12.5	8.8
	1000	72	25.9	2.2	21.7	18.0	14.4	10.7	-	-	24.1	2.3	20.2	17.7	13.7	9.7	-
67		24.4	2.1	21.8	21.8	19.6	15.9	12.3	-	21.9	2.3	20.2	20.2	18.8	14.8	10.8	-
62		23.1	2.1	21.8	21.8	21.8	18.1	14.5	10.8	21.0	2.3	20.2	20.2	20.2	16.1	12.2	8.2
57		21.8	2.1	21.8	21.8	21.8	18.2	14.5	10.9	20.2	2.2	20.2	20.2	20.2	16.2	12.2	8.2

TABLE 3: COOLING CAPACITIES - 2 TON (ACP024) (CONTINUED)

Air on Evaporator Coil		Temperature of Air on Condenser Coil															
CFM	WB (°F)	Total Capacity ¹ (MBh)	Total Input (kW) ²	Sensible Capacity (MBh)						Total Capacity ¹ (MBh)	Total Input (kW) ²	Sensible Capacity (MBh)					
				Return Dry Bulb (°F)								Return Dry Bulb (°F)					
				90	85	80	75	70	65			90	85	80	75	70	65
115°F										125°F							
600	77	22.9	2.5	11.4	8.7	6.0	-	-	-	21.2	2.7	11.0	8.2	5.4	-	-	-
	72	20.4	2.4	15.0	12.3	9.6	6.9	-	-	18.1	2.6	14.4	11.6	8.8	6.0	-	-
	67	17.8	2.3	17.0	16.0	13.2	10.5	7.8	-	15.1	2.5	15.0	15.0	12.2	9.4	6.6	-
	62	17.4	2.3	17.0	16.9	14.2	11.5	8.8	6.1	15.0	2.4	15.0	15.0	12.6	9.8	7.0	4.2
	57	17.0	2.3	17.0	17.0	15.1	12.4	9.6	6.9	15.0	2.4	15.0	15.0	13.2	10.4	7.6	4.8
700	77	23.4	2.6	14.5	10.3	6.5	-	-	-	21.8	2.8	13.4	10.2	5.9	-	-	-
	72	20.8	2.5	16.4	13.6	10.4	7.3	-	-	18.7	2.6	15.3	12.9	9.7	6.4	-	-
	67	18.2	2.3	17.3	16.8	14.4	11.3	8.1	-	15.5	2.5	15.3	15.3	13.4	10.1	6.9	-
	62	17.8	2.3	17.3	17.3	15.5	12.3	9.2	6.1	15.5	2.5	15.3	15.3	13.9	10.7	7.3	4.1
	57	17.3	2.3	17.3	17.3	16.4	13.3	10.1	7.0	15.4	2.5	15.4	15.4	14.5	11.4	8.0	4.7
800	77	23.9	2.6	17.7	11.9	7.0	-	-	-	22.5	2.8	15.8	12.3	6.5	-	-	-
	72	21.3	2.5	17.7	14.8	11.3	7.7	-	-	19.2	2.7	15.8	14.3	10.5	6.8	-	-
	67	18.6	2.4	17.7	17.7	15.5	12.0	8.5	-	16.0	2.5	15.8	15.8	14.6	10.9	7.1	-
	62	18.2	2.4	17.7	17.7	16.7	13.2	9.6	6.1	15.9	2.5	15.8	15.8	15.1	11.6	7.7	3.9
	57	17.7	2.3	17.7	17.7	17.7	14.2	10.6	7.1	15.9	2.5	15.9	15.9	15.9	12.3	8.4	4.6
900	72	21.7	2.5	18.1	16.1	12.2	8.2	-	-	19.8	2.7	16.3	15.7	11.5	7.3	-	-
	67	19.0	2.4	18.1	18.1	16.8	12.8	8.9	-	16.5	2.5	16.3	16.3	15.9	11.7	7.5	-
	62	18.6	2.4	18.1	18.1	17.6	13.6	9.7	5.8	16.4	2.5	16.3	16.3	16.0	11.8	7.6	3.4
	57	18.1	2.4	18.1	18.1	18.1	14.1	10.2	6.3	16.3	2.5	16.3	16.3	16.3	12.2	7.9	3.7
	1000	72	22.2	2.5	18.5	17.4	13.1	8.7	-	-	20.3	2.7	16.8	17.1	12.4	7.7	-
67		19.4	2.4	18.5	18.5	18.0	13.7	9.3	-	16.9	2.6	16.8	16.8	16.8	12.1	7.9	-
62		19.0	2.4	18.5	18.5	18.5	14.1	9.8	5.5	16.9	2.6	16.8	16.8	16.8	12.1	7.5	2.8
57		18.5	2.4	18.5	18.5	18.5	14.1	9.8	5.5	16.8	2.5	16.8	16.8	16.8	12.1	7.5	2.8

1. These capacities are Net Capacities.
2. These ratings include the compressor, condenser fan and supply air blower motors.

TABLE 4: COOLING CAPACITIES - 2-1/2 TON (ACP030)

Air on Evaporator Coil		Temperature of Air on Condenser Coil															
CFM	WB (°F)	Total Capacity ¹ (MBh)	Total Input (kW) ²	Sensible Capacity (MBh)						Total Capacity ¹ (MBh)	Total Input (kW) ²	Sensible Capacity (MBh)					
				Return Dry Bulb (°F)								Return Dry Bulb (°F)					
				90	85	80	75	70	65			90	85	80	75	70	65
				75°F						85°F							
750	77	33.1	2.0	14.8	12.2	9.6	-	-	-	32.4	2.3	14.8	12.0	9.2	-	-	-
	72	32.5	2.1	19.9	17.3	14.7	12.1	-	-	31.4	2.3	19.8	17.0	14.2	11.4	-	-
	67	31.9	2.2	25.0	22.4	19.8	17.2	14.7	-	30.3	2.3	24.9	22.1	19.3	16.5	13.7	-
	62	31.1	2.0	31.0	28.5	25.9	23.3	20.8	18.2	29.0	2.2	29.0	27.7	24.9	22.1	19.3	16.5
	57	31.0	2.0	31.0	30.4	27.9	25.3	22.7	20.2	29.1	2.2	29.1	28.8	26.0	23.2	20.4	17.6
875	77	33.3	2.0	15.2	12.8	10.0	-	-	-	32.7	2.3	15.9	12.7	9.6	-	-	-
	72	32.7	2.1	21.0	18.2	15.3	12.5	-	-	31.6	2.3	21.1	18.0	14.9	11.8	-	-
	67	32.1	2.2	26.7	23.5	20.6	17.8	15.0	-	30.6	2.3	26.4	23.3	20.2	17.1	14.0	-
	62	31.3	2.0	31.2	30.0	27.0	24.4	21.3	18.5	29.3	2.2	29.3	28.6	26.1	23.0	19.8	16.7
	57	31.2	2.0	31.2	30.9	29.1	26.6	23.4	20.6	29.3	2.2	29.3	29.2	27.3	24.1	21.0	17.9
1000	77	33.5	2.0	15.7	13.5	10.4	-	-	-	32.9	2.3	16.9	13.5	10.1	-	-	-
	72	32.9	2.1	22.1	19.0	15.9	12.9	-	-	31.8	2.3	22.4	19.0	15.6	12.2	-	-
	67	32.3	2.2	28.5	24.5	21.5	18.4	15.3	-	30.8	2.3	28.0	24.5	21.1	17.7	14.2	-
	62	31.5	2.1	31.4	31.4	28.1	25.5	21.9	18.8	29.5	2.2	29.5	29.5	27.3	23.8	20.4	17.0
	57	31.4	2.0	31.4	31.4	30.2	27.8	24.1	21.0	29.6	2.2	29.6	29.6	28.5	25.1	21.6	18.2
1125	72	33.2	2.1	23.1	19.8	16.6	13.3	-	-	32.1	2.3	23.6	19.9	16.3	12.6	-	-
	67	32.5	2.2	30.3	25.5	22.3	19.1	15.8	-	31.0	2.4	28.9	25.7	22.1	18.4	14.7	-
	62	31.8	2.1	31.6	31.6	29.8	26.8	23.3	20.1	29.7	2.2	29.7	29.7	28.5	24.8	21.2	17.5
	57	31.6	2.0	31.6	31.6	31.0	28.1	24.5	21.3	29.8	2.2	29.8	29.8	29.2	25.6	21.9	18.3
	72	33.4	2.1	24.0	20.6	17.2	13.8	-	-	32.3	2.3	24.8	20.9	17.0	13.1	-	-
1250	67	32.8	2.2	31.8	26.5	23.1	19.7	16.3	-	31.2	2.4	29.9	26.9	23.0	19.1	15.2	-
	62	32.0	2.1	31.8	31.8	31.6	28.2	24.7	21.3	29.9	2.3	29.9	29.9	29.7	25.8	21.9	18.0
	57	31.8	2.0	31.8	31.8	31.8	28.4	25.0	21.6	30.0	2.2	30.0	30.0	30.0	26.1	22.2	18.3
					95°F						105°F						
	750	77	31.8	2.5	14.8	11.8	8.8	-	-	-	30.8	2.7	14.3	11.2	8.1	-	-
72		30.3	2.5	19.8	16.8	13.7	10.7	-	-	28.8	2.6	19.1	15.9	12.8	9.7	-	-
67		28.8	2.4	24.8	21.7	18.7	15.7	12.7	-	26.8	2.6	23.8	20.7	17.6	14.5	11.4	-
62		27.0	2.4	27.0	26.9	23.9	20.8	17.8	14.8	25.3	2.5	25.3	24.9	21.8	18.7	15.6	12.5
57		27.3	2.3	27.3	27.2	24.2	21.1	18.1	15.1	25.6	2.5	25.6	24.9	21.8	18.7	15.6	12.5
875	77	32.0	2.5	16.5	12.6	9.2	-	-	-	30.7	2.7	17.0	12.2	8.6	-	-	-
	72	30.5	2.5	21.3	17.9	14.5	11.1	-	-	28.7	2.7	20.7	17.2	13.7	10.1	-	-
	67	29.0	2.5	26.1	23.1	19.7	16.3	12.9	-	26.7	2.6	24.5	22.2	18.7	15.2	11.7	-
	62	27.2	2.4	27.2	27.2	25.2	21.5	18.3	14.9	25.2	2.6	25.2	25.0	23.2	19.5	16.1	12.6
	57	27.5	2.4	27.5	27.4	25.5	21.7	18.7	15.3	25.5	2.6	25.5	25.2	23.2	19.5	16.2	12.6
1000	77	32.3	2.5	18.2	13.5	9.7	-	-	-	30.5	2.8	19.6	13.2	9.1	-	-	-
	72	30.8	2.5	22.8	19.0	15.2	11.5	-	-	28.5	2.7	22.4	18.4	14.5	10.5	-	-
	67	29.2	2.5	27.4	24.5	20.7	17.0	13.2	-	26.6	2.7	25.1	23.7	19.8	15.9	11.9	-
	62	27.4	2.4	27.4	27.4	26.4	22.1	18.9	15.1	25.1	2.6	25.1	25.1	24.5	20.3	16.6	12.7
	57	27.7	2.4	27.7	27.7	26.8	22.3	19.2	15.4	25.4	2.6	25.4	25.4	24.6	20.3	16.7	12.7
1125	72	31.0	2.5	24.2	20.1	16.0	11.9	-	-	28.4	2.7	23.6	20.0	15.3	10.9	-	-
	67	29.5	2.5	27.6	25.9	21.8	17.7	13.6	-	26.5	2.7	25.0	24.3	20.9	16.6	12.3	-
	62	27.6	2.4	27.6	27.6	27.2	22.8	19.0	14.9	25.0	2.6	25.0	25.0	24.7	20.3	16.1	11.7
	57	27.9	2.4	27.9	27.9	27.5	23.0	19.3	15.2	25.3	2.6	25.3	25.3	24.9	20.4	16.2	11.9
	1250	72	31.2	2.6	25.5	21.2	16.8	12.4	-	-	28.3	2.8	24.9	21.5	16.1	11.4	-
67		29.7	2.6	27.9	27.2	22.9	18.5	14.1	-	26.4	2.7	24.9	24.9	22.0	17.3	12.6	-
62		27.9	2.5	27.9	27.9	27.9	23.5	19.1	14.7	24.9	2.7	24.9	24.9	24.9	20.2	15.5	10.8
57		28.1	2.4	28.1	28.1	28.1	23.8	19.4	15.0	25.2	2.7	25.2	25.2	25.2	20.5	15.8	11.1

TABLE 4: COOLING CAPACITIES - 2-1/2 TON (ACP030) (CONTINUED)

Air on Evaporator Coil		Temperature of Air on Condenser Coil															
CFM	WB (°F)	Total Capacity ¹ (MBh)	Total Input (kW) ²	Sensible Capacity (MBh)						Total Capacity ¹ (MBh)	Total Input (kW) ²	Sensible Capacity (MBh)					
				Return Dry Bulb (°F)								Return Dry Bulb (°F)					
				90	85	80	75	70	65			90	85	80	75	70	65
				115°F						125°F							
750	77	29.8	2.9	13.7	10.6	7.4	-	-	-	28.8	3.1	13.2	10.0	6.7	-	-	-
	72	27.3	2.8	18.3	15.1	11.9	8.8	-	-	25.8	3.0	17.6	14.3	11.1	7.8	-	-
	67	24.8	2.8	22.9	19.7	16.5	13.3	10.1	-	22.8	2.9	21.9	18.6	15.4	12.1	8.9	-
	62	23.6	2.7	23.6	22.9	19.7	16.6	13.4	10.2	22.0	2.9	22.0	20.9	17.7	14.4	11.2	7.9
	57	24.0	2.7	24.0	22.7	19.5	16.4	13.2	10.0	22.3	2.9	22.3	20.5	17.2	14.0	10.7	7.5
875	77	29.3	2.9	17.4	11.7	7.9	-	-	-	27.9	3.1	16.8	11.2	7.3	-	-	-
	72	26.8	2.9	20.1	16.5	12.8	9.2	-	-	25.0	3.1	19.5	15.8	12.0	8.2	-	-
	67	24.4	2.8	23.2	21.2	17.7	14.1	10.4	-	22.1	3.0	21.2	20.3	16.7	12.9	9.1	-
	62	23.2	2.7	23.2	22.8	21.2	17.5	13.9	10.2	21.2	2.9	21.2	20.7	19.2	15.5	11.6	7.9
	57	23.5	2.8	23.5	22.9	21.0	17.3	13.7	10.0	21.5	3.0	21.5	20.6	18.7	15.1	11.2	7.4
1000	77	28.7	3.0	21.1	12.8	8.5	-	-	-	27.0	3.2	20.4	12.5	7.9	-	-	-
	72	26.3	2.9	21.9	17.8	13.7	9.6	-	-	24.1	3.1	20.4	17.2	12.9	8.6	-	-
	67	23.9	2.9	22.8	22.8	18.9	14.8	10.7	-	21.3	3.0	20.4	20.4	18.0	13.7	9.4	-
	62	22.8	2.8	22.8	22.8	22.6	18.5	14.4	10.2	20.4	3.0	20.4	20.4	20.4	16.7	12.1	7.8
	57	23.1	2.8	23.1	23.1	22.4	18.3	14.1	10.0	20.8	3.0	20.8	20.8	20.8	16.2	11.6	7.3
1125	72	25.8	3.0	22.3	19.9	14.5	9.9	-	-	23.2	3.2	19.6	19.6	13.8	8.9	-	-
	67	23.5	2.9	22.3	22.3	20.0	15.5	10.9	-	20.5	3.1	19.6	19.6	19.1	14.3	9.5	-
	62	22.3	2.8	22.3	22.3	22.3	17.7	13.1	8.6	19.7	3.0	19.7	19.7	19.7	15.1	10.2	5.4
	57	22.7	2.8	22.7	22.7	22.7	17.7	13.2	8.6	20.0	3.0	20.0	20.0	20.0	15.1	10.1	5.3
1250	72	25.3	3.0	21.9	21.9	15.3	10.3	-	-	22.4	3.2	18.9	18.9	14.6	9.3	-	-
	67	23.0	2.9	21.9	21.9	21.2	16.1	11.1	-	19.7	3.1	18.9	18.9	18.9	15.0	9.7	-
	62	21.9	2.9	21.9	21.9	21.9	16.9	11.9	6.9	18.9	3.1	18.9	18.9	18.9	13.6	8.3	3.0
	57	22.2	2.9	22.2	22.2	22.2	17.2	12.2	7.2	19.3	3.1	19.3	19.3	19.3	13.9	8.6	3.3

1. These capacities are Net Capacities.
2. These ratings include the compressor, condenser fan and supply air blower motors.

TABLE 5: COOLING CAPACITIES - 3 TON (ACP036)

Air on Evaporator Coil		Temperature of Air on Condenser Coil															
CFM	WB (°F)	Total Capacity ¹ (MBh)	Total Input (kW) ²	Sensible Capacity (MBh)						Total Capacity ¹ (MBh)	Total Input (kW) ²	Sensible Capacity (MBh)					
				Return Dry Bulb (°F)								Return Dry Bulb (°F)					
				90	85	80	75	70	65			90	85	80	75	70	65
				75°F						85°F							
1000	77	45.2	2.8	21.4	17.8	14.2	-	-	-	43.9	3.0	21.0	17.2	13.5	-	-	-
	72	43.3	2.7	27.6	24.0	20.4	16.7	-	-	41.1	2.9	26.9	23.2	19.5	15.8	-	-
	67	41.4	2.5	33.7	30.1	26.5	22.9	19.3	-	38.3	2.8	32.9	29.1	25.4	21.7	18.0	-
	62	38.0	2.4	38.0	36.7	31.8	28.2	24.6	21.0	34.9	2.7	34.9	34.3	30.6	26.9	23.2	19.5
	57	35.6	2.5	35.6	35.6	35.2	31.6	28.0	24.4	33.4	2.7	33.4	33.4	33.1	29.4	25.6	21.9
1125	77	45.8	2.9	23.7	19.4	14.9	-	-	-	44.8	3.1	23.2	18.7	14.2	-	-	-
	72	43.9	2.8	30.3	25.8	21.3	16.8	-	-	41.9	3.0	29.4	25.0	20.5	16.0	-	-
	67	42.0	2.6	36.9	32.2	27.7	23.2	18.7	-	39.0	2.9	35.7	31.2	26.7	22.3	17.8	-
	62	38.5	2.5	38.5	37.9	32.9	28.6	23.9	19.4	35.6	2.8	35.6	35.3	32.2	27.7	23.2	18.7
	57	36.0	2.7	36.0	36.0	35.9	31.6	26.9	22.4	34.0	2.8	34.0	34.0	33.9	29.4	24.9	20.4
1250	77	46.4	3.1	26.0	21.0	15.6	-	-	-	45.6	3.1	25.4	20.2	14.9	-	-	-
	72	44.5	2.9	33.1	27.7	22.3	16.9	-	-	42.7	3.1	32.0	26.7	21.5	16.2	-	-
	67	42.5	2.7	40.2	34.4	29.0	23.6	18.1	-	39.7	3.0	38.5	33.3	28.0	22.8	17.6	-
	62	39.1	2.6	39.1	39.1	34.0	29.0	23.2	17.8	36.3	2.8	36.3	36.3	33.7	28.5	23.2	18.0
	57	36.5	2.8	36.5	36.5	36.5	31.7	25.7	20.3	34.6	2.9	34.6	34.6	34.6	29.4	24.1	18.9
1375	72	44.9	3.0	35.3	29.4	23.6	17.7	-	-	43.1	3.1	34.2	28.4	22.7	16.9	-	-
	67	42.9	2.8	41.7	36.5	30.7	24.8	19.0	-	40.1	3.0	39.5	35.4	29.6	23.8	18.1	-
	62	39.4	2.7	39.4	39.4	36.9	31.2	25.2	19.3	36.6	2.9	36.6	36.6	35.3	29.6	23.8	18.0
	57	36.9	2.8	36.9	36.9	36.9	31.3	25.2	19.3	35.0	2.9	35.0	35.0	35.0	29.2	23.4	17.7
	72	45.2	3.0	37.4	31.2	24.9	18.6	-	-	43.5	3.1	36.4	30.1	23.8	17.6	-	-
1500	67	43.3	2.8	43.3	38.6	32.4	26.1	19.8	-	40.5	3.1	40.5	37.4	31.1	24.8	18.5	-
	62	39.7	2.7	39.7	39.7	39.7	33.4	27.2	20.9	36.9	2.9	36.9	36.9	36.9	30.6	24.4	18.1
	57	37.2	2.9	37.2	37.2	37.2	30.9	24.6	18.3	35.3	3.0	35.3	35.3	35.3	29.0	22.7	16.4
					95°F						105°F						
	1000	77	42.6	3.1	20.5	16.7	12.8	-	-	-	39.3	3.4	19.2	15.5	11.9	-	-
72		38.9	3.1	26.3	22.4	18.6	14.8	-	-	35.7	3.3	24.7	21.1	17.4	13.8	-	-
67		35.1	3.1	32.0	28.2	24.4	20.6	16.8	-	32.2	3.3	30.3	26.7	23.0	19.3	15.7	-
62		31.8	3.0	31.8	31.8	29.4	25.6	21.7	17.9	29.3	3.1	29.3	29.3	28.2	24.5	20.8	17.2
57		31.2	2.9	31.2	31.2	30.9	27.1	23.3	19.5	28.8	3.1	28.8	28.8	28.7	25.0	21.4	17.7
1125	77	43.7	3.2	22.6	18.0	13.6	-	-	-	40.2	3.4	23.0	17.1	12.6	-	-	-
	72	39.9	3.2	28.6	24.1	19.7	15.2	-	-	36.6	3.4	27.5	23.1	18.6	14.1	-	-
	67	36.0	3.2	34.5	30.2	25.8	21.3	16.9	-	33.0	3.4	32.0	29.0	24.5	20.1	15.6	-
	62	32.7	3.0	32.7	32.7	31.4	26.8	22.5	18.1	29.9	3.2	29.9	29.9	29.4	24.8	20.4	16.0
	57	31.9	3.0	31.9	31.9	31.8	27.1	22.9	18.5	29.5	3.2	29.5	29.5	29.4	24.8	20.5	16.0
1250	77	44.8	3.2	24.8	19.3	14.3	-	-	-	41.1	3.5	26.9	18.7	13.4	-	-	-
	72	40.8	3.2	30.9	25.8	20.7	15.6	-	-	37.4	3.5	30.3	25.0	19.7	14.5	-	-
	67	36.9	3.2	36.9	32.2	27.1	22.0	17.0	-	33.7	3.4	33.7	31.3	26.1	20.8	15.5	-
	62	33.5	3.0	33.5	33.5	33.5	28.0	23.3	18.2	30.6	3.3	30.6	30.6	30.6	25.1	20.0	14.8
	57	32.7	3.0	32.7	32.7	32.7	27.1	22.6	17.5	30.2	3.3	30.2	30.2	30.2	24.6	19.6	14.3
1375	72	41.3	3.3	33.1	27.4	21.8	16.1	-	-	37.8	3.5	32.1	26.4	20.6	14.8	-	-
	67	37.3	3.3	37.3	34.2	28.5	22.8	17.1	-	34.0	3.5	34.0	32.5	27.2	21.4	15.6	-
	62	33.8	3.1	33.8	33.8	33.8	27.9	22.4	16.7	30.9	3.3	30.9	30.9	30.9	25.1	19.4	13.6
	57	33.1	3.0	33.1	33.1	33.1	27.1	21.7	16.0	30.5	3.3	30.5	30.5	30.5	24.6	18.9	13.2
	72	41.7	3.3	35.4	29.1	22.8	16.5	-	-	38.1	3.6	33.9	27.7	21.4	15.2	-	-
1500	67	37.6	3.3	37.6	36.2	29.9	23.6	17.3	-	34.4	3.5	34.4	33.6	28.3	22.0	15.8	-
	62	34.1	3.1	34.1	34.1	34.1	27.8	21.6	15.3	31.2	3.4	31.2	31.2	31.2	25.0	18.7	12.5
	57	33.4	3.1	33.4	33.4	33.4	27.1	20.8	14.5	30.8	3.3	30.8	30.8	30.8	24.5	18.3	12.0

TABLE 5: COOLING CAPACITIES - 3 TON (ACP036) (CONTINUED)

Air on Evaporator Coil		Temperature of Air on Condenser Coil															
CFM	WB (°F)	Total Capacity ¹ (MBh)	Total Input (kW) ²	Sensible Capacity (MBh)						Total Capacity ¹ (MBh)	Total Input (kW) ²	Sensible Capacity (MBh)					
				Return Dry Bulb (°F)								Return Dry Bulb (°F)					
				90	85	80	75	70	65			90	85	80	75	70	65
				115°F						125°F							
1000	77	36.0	3.6	17.9	14.4	10.9	-	-	-	32.6	3.9	16.6	13.2	9.9	-	-	-
	72	32.6	3.5	23.2	19.7	16.2	12.8	-	-	29.5	3.8	21.7	18.4	15.1	11.7	-	-
	67	29.3	3.4	28.6	25.1	21.6	18.1	14.6	-	26.4	3.6	26.4	23.5	20.2	16.9	13.6	-
	62	26.7	3.3	26.7	26.7	26.9	23.4	20.0	16.5	24.1	3.5	24.1	24.1	24.1	22.4	19.1	15.7
	57	26.5	3.3	26.5	26.5	26.4	23.0	19.5	16.0	24.2	3.6	24.2	24.2	24.2	20.9	17.6	14.2
1125	77	36.7	3.7	23.4	16.2	11.7	-	-	-	33.2	4.0	23.8	15.3	10.8	-	-	-
	72	33.3	3.6	26.5	22.0	17.5	13.0	-	-	30.0	3.9	25.5	20.9	16.4	11.9	-	-
	67	29.9	3.5	29.5	27.8	23.3	18.8	14.3	-	26.8	3.7	26.8	26.6	22.1	17.5	13.0	-
	62	27.2	3.4	27.2	27.2	27.4	22.9	18.4	13.9	24.5	3.6	24.5	24.5	24.5	20.9	16.3	11.8
	57	27.1	3.4	27.1	27.1	27.0	22.5	18.1	13.6	24.6	3.7	24.6	24.6	24.6	20.3	15.6	11.1
1250	77	37.4	3.8	29.0	18.1	12.6	-	-	-	33.7	4.1	31.1	17.4	11.7	-	-	-
	72	34.0	3.7	29.8	24.3	18.8	13.3	-	-	30.5	4.0	29.2	23.5	17.8	12.1	-	-
	67	30.5	3.6	30.5	30.5	25.0	19.5	14.0	-	27.3	3.8	27.3	27.3	23.9	18.2	12.5	-
	62	27.8	3.5	27.8	27.8	27.8	22.3	16.8	11.3	24.9	3.8	24.9	24.9	24.9	19.4	13.5	7.8
	57	27.6	3.5	27.6	27.6	27.6	22.1	16.6	11.1	25.1	3.8	25.1	25.1	25.1	19.6	13.7	8.0
1375	72	34.3	3.8	31.1	25.3	19.4	13.6	-	-	30.8	4.0	30.1	24.2	18.3	12.3	-	-
	67	30.8	3.7	30.8	30.8	25.8	20.0	14.1	-	27.6	3.9	27.6	27.6	24.5	18.5	12.6	-
	62	28.0	3.6	28.0	28.0	28.0	22.2	16.3	10.5	25.2	3.8	25.2	25.2	25.2	19.3	13.3	7.3
	57	27.9	3.6	27.9	27.9	27.9	22.0	16.2	10.3	25.3	3.8	25.3	25.3	25.3	19.5	13.4	7.5
	1500	72	34.6	3.8	32.5	26.3	20.1	13.8	-	-	31.1	4.1	31.1	24.9	18.7	12.5	-
67		31.1	3.7	31.1	31.1	26.7	20.5	14.2	-	27.8	3.9	27.8	27.8	25.1	18.9	12.7	-
62		28.3	3.6	28.3	28.3	28.3	22.1	15.9	9.6	25.4	3.8	25.4	25.4	25.4	19.2	13.0	6.8
57		28.2	3.6	28.2	28.2	28.2	21.9	15.7	9.5	25.5	3.9	25.5	25.5	25.5	19.4	13.2	7.0

1. These capacities are Net Capacities.
2. These ratings include the compressor, condenser fan and supply air blower motors.

TABLE 6: COOLING CAPACITIES - 3-1/2 TON (ACP042)

Air on Evaporator Coil		Temperature of Air on Condenser Coil															
CFM	WB (°F)	Total Capacity ¹ (MBh)	Total Input (kW) ²	Sensible Capacity (MBh)						Total Capacity ¹ (MBh)	Total Input (kW) ²	Sensible Capacity (MBh)					
				Return Dry Bulb (°F)								Return Dry Bulb (°F)					
				90	85	80	75	70	65			90	85	80	75	70	65
				75°F						85°F							
1050	77	51.5	3.0	23.9	19.9	16.0	-	-	-	49.7	3.4	23.2	19.2	15.2	-	-	-
	72	48.4	3.0	30.8	26.8	22.8	18.8	-	-	46.3	3.3	29.9	25.9	21.9	17.8	-	-
	67	45.3	2.9	37.6	33.6	29.7	25.7	21.7	-	43.0	3.3	36.7	32.6	28.6	24.5	20.5	-
	62	42.5	2.9	41.6	41.6	37.1	33.2	29.2	25.2	39.6	3.2	39.4	39.4	35.6	31.6	27.6	23.5
	57	41.6	2.8	41.6	41.6	39.4	35.4	31.5	27.5	39.4	3.1	39.4	39.4	37.2	33.2	29.2	25.1
1175	77	51.7	3.0	24.1	20.6	16.2	-	-	-	49.9	3.4	24.4	19.9	15.4	-	-	-
	72	48.6	3.0	31.9	27.6	23.2	18.8	-	-	46.5	3.4	31.2	26.7	22.3	17.8	-	-
	67	45.5	2.9	39.2	34.5	30.2	25.8	21.4	-	43.1	3.3	38.0	33.6	29.1	24.7	20.2	-
	62	42.6	2.9	41.8	41.8	37.7	33.6	29.0	24.6	39.8	3.2	39.6	39.6	36.3	31.9	27.4	22.9
	57	41.8	2.8	41.8	41.8	40.1	36.0	31.3	26.9	39.6	3.2	39.6	39.6	38.0	33.5	29.0	24.6
1300	77	51.9	3.1	24.4	21.3	16.5	-	-	-	50.0	3.4	25.5	20.6	15.7	-	-	-
	72	48.8	3.0	33.1	28.3	23.6	18.8	-	-	46.7	3.4	32.5	27.6	22.7	17.8	-	-
	67	45.6	3.0	41.9	35.4	30.7	25.9	21.1	-	43.3	3.3	39.4	34.6	29.7	24.8	19.9	-
	62	42.8	2.9	41.9	41.9	38.4	34.1	28.8	24.0	39.9	3.3	39.7	39.7	37.0	32.1	27.2	22.4
	57	41.9	2.8	41.9	41.9	40.7	36.6	31.2	26.4	39.7	3.2	39.7	39.7	38.7	33.8	28.9	24.0
1400	72	49.1	3.1	34.3	29.3	24.4	19.4	-	-	47.0	3.5	33.8	28.7	23.6	18.5	-	-
	67	45.9	3.0	42.7	36.6	31.7	26.7	21.7	-	43.6	3.4	40.0	35.9	30.8	25.7	20.6	-
	62	43.0	3.0	42.2	42.2	40.2	35.5	30.3	25.3	40.2	3.3	40.0	40.0	38.4	33.3	28.2	23.1
	57	42.2	2.9	42.2	42.2	41.6	37.0	31.7	26.7	40.0	3.3	40.0	40.0	39.5	34.4	29.3	24.2
	72	49.4	3.1	35.5	30.3	25.1	20.0	-	-	47.3	3.5	35.1	29.8	24.4	19.1	-	-
1500	67	46.2	3.1	42.5	37.8	32.7	27.5	22.4	-	43.9	3.5	40.3	37.3	32.0	26.6	21.3	-
	62	43.3	3.1	42.5	42.5	42.0	36.9	31.7	26.6	40.5	3.4	40.3	40.3	39.8	34.5	29.1	23.8
	57	42.5	3.0	42.5	42.5	42.5	37.3	32.1	27.0	40.3	3.3	40.3	40.3	40.3	35.0	29.6	24.3
					95°F						105°F						
	1050	77	47.9	3.8	22.6	18.4	14.3	-	-	-	45.4	4.2	21.5	17.3	13.1	-	-
72		44.2	3.7	29.1	25.0	20.9	16.8	-	-	41.7	4.1	28.3	24.1	19.9	15.7	-	-
67		40.6	3.6	35.7	31.6	27.5	23.4	19.3	-	37.9	4.0	34.4	30.8	26.6	22.4	18.2	-
62		36.7	3.5	36.7	36.7	34.1	30.0	25.9	21.8	34.4	3.9	34.4	34.4	32.6	28.4	24.2	20.0
57		37.2	3.5	37.2	37.2	35.1	31.0	26.9	22.8	35.0	3.9	35.0	35.0	33.4	29.2	25.0	20.8
1175	77	48.0	3.8	24.6	19.2	14.7	-	-	-	45.5	4.2	24.4	18.0	13.4	-	-	-
	72	44.4	3.7	30.5	25.9	21.4	16.8	-	-	41.8	4.1	29.6	24.9	20.3	15.7	-	-
	67	40.8	3.6	36.9	32.6	28.1	23.6	19.0	-	38.1	4.1	34.5	31.8	27.2	22.5	17.9	-
	62	36.9	3.6	36.9	36.9	34.9	30.1	25.8	21.3	34.5	4.0	34.5	34.5	33.2	28.5	23.9	19.3
	57	37.4	3.5	37.4	37.4	35.8	31.0	26.8	22.2	35.1	3.9	35.1	35.1	34.1	29.3	24.8	20.2
1300	77	48.2	3.8	26.6	20.0	15.0	-	-	-	45.7	4.3	27.3	18.8	13.7	-	-	-
	72	44.6	3.8	31.8	26.8	21.8	16.9	-	-	41.9	4.2	30.9	25.8	20.7	15.6	-	-
	67	40.9	3.7	37.0	33.7	28.7	23.7	18.7	-	38.2	4.1	34.6	32.8	27.7	22.7	17.6	-
	62	37.0	3.6	37.0	37.0	35.6	30.2	25.7	20.7	34.6	4.0	34.6	34.6	33.9	28.6	23.7	18.6
	57	37.5	3.5	37.5	37.5	36.6	31.0	26.7	21.7	35.2	4.0	35.2	35.2	34.8	29.4	24.6	19.5
1400	72	44.9	3.8	33.3	28.1	22.8	17.6	-	-	42.2	4.2	32.3	26.9	21.6	16.2	-	-
	67	41.3	3.7	37.3	35.2	30.0	24.7	19.5	-	38.4	4.2	34.8	34.0	28.9	23.5	18.2	-
	62	37.3	3.7	37.3	37.3	36.6	31.1	26.1	20.9	34.8	4.1	34.8	34.8	34.5	29.0	23.8	18.4
	57	37.8	3.6	37.8	37.8	37.4	31.8	26.9	21.6	35.5	4.0	35.5	35.5	35.3	29.7	24.5	19.2
	72	45.3	3.9	34.8	29.3	23.8	18.2	-	-	42.5	4.3	33.6	28.1	22.4	16.8	-	-
1500	67	41.6	3.8	37.6	36.7	31.2	25.7	20.2	-	38.7	4.2	35.1	35.1	30.0	24.4	18.8	-
	62	37.6	3.7	37.6	37.6	37.6	32.1	26.6	21.1	35.1	4.1	35.1	35.1	35.1	29.4	23.8	18.2
	57	38.1	3.7	38.1	38.1	38.1	32.6	27.1	21.6	35.7	4.1	35.7	35.7	35.7	30.1	24.4	18.8

TABLE 6: COOLING CAPACITIES - 3-1/2 TON (ACP042) (CONTINUED)

Air on Evaporator Coil		Temperature of Air on Condenser Coil																	
CFM	WB (°F)	Total Capacity ¹ (MBh)	Total Input (kW) ²	Sensible Capacity (MBh)								Total Capacity ¹ (MBh)	Total Input (kW) ²	Sensible Capacity (MBh)					
				Return Dry Bulb (°F)										Return Dry Bulb (°F)					
				90	85	80	75	70	65	90	85			80	75	70	65		
				115°F								125°F							
1050	77	42.9	4.6	20.5	16.2	11.9	-	-	-	40.5	5.1	19.5	15.1	10.7	-	-	-		
	72	39.1	4.5	27.4	23.1	18.8	14.6	-	-	36.5	5.0	26.6	22.2	17.8	13.4	-	-		
	67	35.3	4.5	32.1	30.1	25.8	21.5	17.2	-	32.6	4.9	29.7	29.3	24.9	20.5	16.1	-		
	62	32.1	4.4	32.1	32.1	31.0	26.7	22.4	18.1	29.7	4.8	29.7	29.7	29.4	25.0	20.7	16.3		
	57	32.8	4.3	32.8	32.8	31.8	27.5	23.2	18.9	30.6	4.8	30.6	30.6	30.1	25.7	21.3	17.0		
1175	77	43.0	4.7	24.2	16.9	12.1	-	-	-	40.5	5.1	24.1	15.7	10.9	-	-	-		
	72	39.2	4.6	28.7	24.0	19.2	14.5	-	-	36.6	5.0	27.8	23.0	18.1	13.3	-	-		
	67	35.3	4.5	32.1	31.0	26.3	21.5	16.8	-	32.6	4.9	29.7	29.7	25.4	20.5	15.7	-		
	62	32.1	4.4	32.1	32.1	31.6	26.8	22.1	17.4	29.8	4.8	29.8	29.8	29.8	25.2	20.3	15.4		
	57	32.9	4.4	32.9	32.9	32.4	27.6	22.9	18.1	30.6	4.8	30.6	30.6	30.6	26.0	20.9	16.1		
1300	77	43.1	4.7	28.0	17.6	12.4	-	-	-	40.6	5.1	28.7	16.4	11.1	-	-	-		
	72	39.3	4.6	30.0	24.8	19.6	14.4	-	-	36.6	5.0	29.1	23.8	18.4	13.1	-	-		
	67	35.4	4.5	32.0	32.0	26.8	21.6	16.4	-	32.7	4.9	29.4	29.4	25.8	20.5	15.2	-		
	62	32.2	4.4	32.2	32.2	32.2	27.0	21.8	16.6	29.8	4.8	29.8	29.8	29.8	25.4	19.9	14.5		
	57	33.0	4.4	33.0	33.0	33.0	27.8	22.6	17.4	30.7	4.8	30.7	30.7	30.7	26.2	20.6	15.2		
1400	72	39.5	4.7	31.2	25.8	20.3	14.9	-	-	36.7	5.1	29.9	24.7	19.1	13.5	-	-		
	67	35.6	4.6	32.4	32.4	27.8	22.3	16.9	-	32.8	5.0	29.9	29.9	26.7	21.1	15.6	-		
	62	32.4	4.5	32.4	32.4	32.4	26.9	21.4	15.9	29.9	4.9	29.9	29.9	29.9	24.8	19.0	13.5		
	57	33.1	4.5	33.1	33.1	33.1	27.7	22.2	16.7	30.8	4.9	30.8	30.8	30.8	25.6	19.8	14.2		
	1500	72	39.6	4.7	32.5	26.9	21.1	15.3	-	-	36.8	5.2	29.9	25.6	19.8	13.9	-	-	
67		35.8	4.6	32.5	32.5	28.9	23.1	17.3	-	32.8	5.1	29.9	29.9	27.7	21.8	15.9	-		
62		32.5	4.5	32.5	32.5	32.5	26.8	21.0	15.3	30.0	4.9	30.0	30.0	30.0	24.1	18.2	12.4		
57		33.3	4.5	33.3	33.3	33.3	27.5	21.8	16.0	30.8	5.0	30.8	30.8	30.8	25.0	19.1	13.2		

1. These capacities are Net Capacities.
2. These ratings include the compressor, condenser fan and supply air blower motors.

TABLE 7: COOLING CAPACITIES - 4 TON (ACP048)

Air on Evaporator Coil		Temperature of Air on Condenser Coil																
CFM	WB (°F)	Total Capacity ¹ (MBh)	Total Input (kW) ²	Sensible Capacity (MBh)							Total Capacity ¹ (MBh)	Total Input (kW) ²	Sensible Capacity (MBh)					
				Return Dry Bulb (°F)									Return Dry Bulb (°F)					
				90	85	80	75	70	65	90			85	80	75	70	65	
				75°F							85°F							
1200	77	59.1	3.2	26.7	22.4	18.1	-	-	-	56.5	3.6	26.6	22.1	17.7	-	-	-	
	72	54.6	3.1	34.2	29.9	25.6	21.2	-	-	51.8	3.5	33.6	29.2	24.7	20.3	-	-	
	67	50.1	3.1	41.7	37.4	33.0	28.7	24.4	-	47.1	3.5	40.7	36.2	31.8	27.3	22.9	-	
	62	46.0	3.1	46.0	44.8	38.6	34.3	30.0	25.7	42.7	3.5	42.7	42.1	37.7	33.2	28.8	24.3	
	57	44.7	3.5	44.7	44.7	44.7	40.4	36.0	31.7	41.1	3.4	41.1	41.1	41.1	36.7	32.2	27.8	
1400	77	60.5	3.2	30.1	25.0	19.3	-	-	-	57.8	3.7	30.4	24.6	19.0	-	-	-	
	72	55.9	3.2	38.6	33.0	27.3	21.7	-	-	53.0	3.6	37.7	32.1	26.5	21.0	-	-	
	67	51.2	3.2	47.0	41.0	35.4	29.7	24.1	-	48.2	3.6	45.0	39.7	34.1	28.5	23.0	-	
	62	47.1	3.2	47.1	46.5	41.8	36.5	30.6	25.0	43.8	3.6	43.8	43.5	40.5	34.9	29.3	23.7	
	57	45.7	3.6	45.7	45.7	45.7	40.5	34.5	28.9	42.1	3.5	42.1	42.1	42.1	36.6	31.0	25.4	
1600	77	61.9	3.3	33.6	27.5	20.6	-	-	-	59.2	3.8	34.2	27.0	20.3	-	-	-	
	72	57.2	3.3	43.0	36.1	29.1	22.2	-	-	54.3	3.8	41.8	35.1	28.4	21.7	-	-	
	67	52.4	3.3	52.4	44.6	37.7	30.7	23.8	-	49.4	3.7	49.4	43.2	36.5	29.7	23.0	-	
	62	48.1	3.3	48.1	48.1	45.0	38.6	31.2	24.2	44.8	3.7	44.8	44.8	43.2	36.5	29.8	23.1	
	57	46.8	3.7	46.8	46.8	46.8	40.6	32.9	26.0	43.1	3.6	43.1	43.1	43.1	36.4	29.7	23.0	
1800	72	57.8	3.4	45.4	37.7	30.1	22.4	-	-	54.9	3.8	44.4	36.9	29.3	21.8	-	-	
	67	53.0	3.3	53.0	46.5	38.9	31.2	23.6	-	49.9	3.8	49.9	45.3	37.7	30.2	22.6	-	
	62	48.7	3.3	48.7	48.7	47.1	39.7	31.8	24.2	45.3	3.7	45.3	45.3	44.5	37.0	29.4	21.9	
	57	47.3	3.8	47.3	47.3	47.3	40.0	32.0	24.4	43.6	3.7	43.6	43.6	43.6	36.1	28.5	21.0	
	72	58.4	3.4	47.8	39.4	31.0	22.7	-	-	55.5	3.9	47.1	38.7	30.3	21.9	-	-	
2000	67	53.6	3.4	53.6	48.5	40.1	31.8	23.4	-	50.5	3.8	50.5	47.3	38.9	30.6	22.2	-	
	62	49.2	3.4	49.2	49.2	49.2	40.8	32.5	24.1	45.8	3.8	45.8	45.8	45.8	37.5	29.1	20.7	
	57	47.8	3.9	47.8	47.8	47.8	39.5	31.1	22.7	44.1	3.7	44.1	44.1	44.1	35.8	27.4	19.0	
					95°F							105°F						
	1200	77	53.8	4.0	26.4	21.9	17.3	-	-	-	50.5	4.5	24.9	20.5	16.1	-	-	-
72		48.9	4.0	33.1	28.5	23.9	19.3	-	-	45.6	4.5	31.3	26.9	22.5	18.1	-	-	
67		44.1	3.9	39.7	35.1	30.5	25.9	21.4	-	40.7	4.4	37.7	33.3	28.9	24.5	20.1	-	
62		39.5	3.8	39.5	39.5	36.7	32.2	27.6	23.0	36.3	4.3	36.3	36.3	34.9	30.5	26.1	21.7	
57		37.6	3.3	37.6	37.6	37.6	33.0	28.4	23.9	35.3	4.0	35.3	35.3	35.3	30.9	26.5	22.2	
1400	77	55.1	4.1	30.7	24.2	18.6	-	-	-	51.7	4.6	30.8	23.0	17.4	-	-	-	
	72	50.2	4.1	36.8	31.3	25.7	20.2	-	-	46.7	4.6	35.5	29.9	24.3	18.7	-	-	
	67	45.2	4.0	43.0	38.4	32.9	27.3	21.8	-	41.7	4.5	40.2	36.8	31.3	25.7	20.1	-	
	62	40.5	4.0	40.5	40.5	39.1	33.3	28.0	22.5	37.2	4.5	37.2	37.2	36.5	30.8	25.3	19.8	
	57	38.5	3.4	38.5	38.5	38.5	32.7	27.5	21.9	36.2	4.1	36.2	36.2	36.2	30.5	25.1	19.5	
1600	77	56.5	4.3	34.9	26.4	19.9	-	-	-	53.0	4.8	36.6	25.5	18.7	-	-	-	
	72	51.4	4.2	40.6	34.1	27.6	21.1	-	-	47.8	4.7	39.7	32.9	26.1	19.4	-	-	
	67	46.3	4.1	46.3	41.8	35.3	28.8	22.2	-	42.7	4.6	42.7	40.4	33.6	26.8	20.1	-	
	62	41.5	4.1	41.5	41.5	41.5	34.5	28.5	22.0	38.1	4.6	38.1	38.1	38.1	31.1	24.6	17.8	
	57	39.5	3.5	39.5	39.5	39.5	32.3	26.5	20.0	37.1	4.2	37.1	37.1	37.1	30.0	23.6	16.8	
1800	72	52.0	4.3	43.5	36.0	28.6	21.1	-	-	48.4	4.8	42.2	34.7	27.1	19.6	-	-	
	67	46.9	4.2	46.9	44.0	36.5	29.1	21.6	-	43.2	4.7	43.2	41.7	34.8	27.3	19.7	-	
	62	42.0	4.2	42.0	42.0	42.0	34.3	27.1	19.6	38.5	4.6	38.5	38.5	38.5	30.9	23.4	15.9	
	57	40.0	3.6	40.0	40.0	40.0	32.2	25.1	17.6	37.5	4.3	37.5	37.5	37.5	29.8	22.4	14.9	
	2000	72	52.6	4.3	46.4	38.0	29.6	21.2	-	-	49.0	4.8	44.8	36.4	28.1	19.7	-	-
67		47.4	4.3	47.4	46.2	37.8	29.4	21.0	-	43.7	4.7	43.7	43.1	36.1	27.8	19.4	-	
62		42.5	4.2	42.5	42.5	42.5	34.1	25.7	17.3	39.0	4.7	39.0	39.0	39.0	30.7	22.3	14.0	
57		40.4	3.6	40.4	40.4	40.4	32.0	23.7	15.3	38.0	4.3	38.0	38.0	38.0	29.6	21.3	12.9	

TABLE 7: COOLING CAPACITIES - 4 TON (ACP048) (CONTINUED)

Air on Evaporator Coil		Temperature of Air on Condenser Coil																	
CFM	WB (°F)	Total Capacity ¹ (MBh)	Total Input (kW) ²	Sensible Capacity (MBh)								Total Capacity ¹ (MBh)	Total Input (kW) ²	Sensible Capacity (MBh)					
				Return Dry Bulb (°F)										Return Dry Bulb (°F)					
				90	85	80	75	70	65	90	85			80	75	70	65		
				115°F								125°F							
1200	77	47.1	5.0	23.3	19.1	14.9	-	-	-	43.8	5.5	21.7	17.7	13.7	-	-	-		
	72	42.2	5.0	29.5	25.3	21.1	16.9	-	-	38.8	5.5	27.7	23.7	19.7	15.7	-	-		
	67	37.2	4.9	35.7	31.5	27.3	23.1	18.9	-	33.7	5.4	33.7	29.7	25.7	21.7	17.7	-		
	62	33.1	4.8	33.1	33.1	33.1	28.9	24.7	20.5	29.9	5.3	29.9	29.9	29.9	27.2	23.2	19.3		
	57	33.0	4.7	33.0	33.0	33.0	28.8	24.7	20.5	30.7	5.4	30.7	30.7	30.7	26.7	22.8	18.8		
1400	77	48.3	5.1	30.9	21.8	16.2	-	-	-	44.9	5.6	31.0	20.6	15.0	-	-	-		
	72	43.2	5.1	34.1	28.5	22.9	17.3	-	-	39.8	5.6	32.7	27.1	21.5	15.8	-	-		
	67	38.1	5.0	37.4	35.2	29.6	24.0	18.4	-	34.6	5.5	34.5	33.6	28.0	22.3	16.7	-		
	62	33.9	4.9	33.9	33.9	33.9	28.3	22.7	17.1	30.6	5.4	30.6	30.6	30.6	25.8	20.0	14.4		
	57	33.9	4.8	33.9	33.9	33.9	28.2	22.6	17.0	31.5	5.5	31.5	31.5	31.5	26.0	20.2	14.6		
1600	77	49.5	5.2	38.4	24.5	17.4	-	-	-	46.0	5.7	40.2	23.5	16.2	-	-	-		
	72	44.3	5.2	38.7	31.7	24.7	17.7	-	-	40.7	5.7	37.8	30.5	23.2	15.9	-	-		
	67	39.1	5.1	39.1	39.0	31.9	24.9	17.9	-	35.4	5.6	35.4	35.4	30.3	23.0	15.7	-		
	62	34.7	5.1	34.7	34.7	34.7	27.7	20.7	13.6	31.4	5.5	31.4	31.4	31.4	24.3	16.8	9.5		
	57	34.7	4.9	34.7	34.7	34.7	27.7	20.6	13.6	32.3	5.6	32.3	32.3	32.3	25.3	17.7	10.4		
1800	72	44.8	5.2	41.0	33.3	25.6	18.0	-	-	41.2	5.7	39.7	32.0	24.2	16.4	-	-		
	67	39.5	5.2	39.5	39.5	33.2	25.5	17.9	-	35.9	5.7	35.9	35.9	31.5	23.7	16.0	-		
	62	35.1	5.1	35.1	35.1	35.1	27.5	19.8	12.2	31.7	5.6	31.7	31.7	31.7	24.1	16.2	8.4		
		57	35.1	5.0	35.1	35.1	35.1	27.4	19.8	12.1	32.7	5.6	32.7	32.7	32.7	25.1	17.1	9.4	
2000	72	45.4	5.3	43.2	34.9	26.6	18.3	-	-	41.7	5.8	41.6	33.4	25.1	16.9	-	-		
	67	40.0	5.2	40.0	40.0	34.4	26.1	17.8	-	36.3	5.7	36.3	36.3	32.7	24.5	16.2	-		
	62	35.6	5.2	35.6	35.6	35.6	27.3	19.0	10.7	32.1	5.6	32.1	32.1	32.1	23.9	15.6	7.4		
		57	35.5	5.0	35.5	35.5	35.5	27.2	18.9	10.6	33.0	5.7	33.0	33.0	33.0	24.8	16.6	8.3	

1. These capacities are Net Capacities.
2. These ratings include the compressor, condenser fan and supply air blower motors.

TABLE 8: COOLING CAPACITIES - 5 TON (ACP060)

Air on Evaporator Coil		Temperature of Air on Condenser Coil																
CFM	WB (°F)	Total Capacity ¹ (MBh)	Total Input (kW) ²	Sensible Capacity (MBh)							Total Capacity ¹ (MBh)	Total Input (kW) ²	Sensible Capacity (MBh)					
				Return Dry Bulb (°F)									Return Dry Bulb (°F)					
				90	85	80	75	70	65	90			85	80	75	70	65	
				75°F							85°F							
1500	77	67.7	4.1	30.6	25.2	19.8	-	-	-	66.6	4.6	29.8	24.3	18.8	-	-	-	
	72	64.0	4.1	40.4	35.0	29.6	24.2	-	-	62.2	4.6	39.6	34.0	28.5	23.0	-	-	
	67	60.2	4.1	50.2	44.8	39.4	34.0	28.6	-	57.8	4.5	49.3	43.8	38.3	32.8	27.3	-	
	62	56.3	4.1	56.3	54.2	48.8	43.4	38.0	32.6	53.7	4.5	53.7	52.6	47.1	41.6	36.1	30.6	
	57	54.0	4.1	54.0	54.0	52.1	46.7	41.3	35.8	51.8	4.5	51.8	51.8	49.4	43.9	38.4	32.9	
1675	77	69.7	4.2	32.6	26.8	20.9	-	-	-	68.3	4.6	31.9	25.9	20.0	-	-	-	
	72	65.8	4.2	43.0	37.1	31.3	25.5	-	-	63.8	4.6	42.2	36.3	30.3	24.4	-	-	
	67	61.9	4.1	53.3	47.5	41.7	35.9	30.0	-	59.3	4.6	52.5	46.6	40.6	34.7	28.8	-	
	62	57.9	4.2	57.9	56.8	51.6	46.2	39.9	34.1	55.1	4.6	55.1	54.5	50.1	44.1	38.2	32.2	
	57	55.5	4.2	55.5	55.5	55.1	49.7	43.4	37.6	53.1	4.6	53.1	53.1	52.5	46.6	40.6	34.7	
1850	77	71.6	4.2	34.6	28.3	22.1	-	-	-	70.0	4.7	33.9	27.5	21.2	-	-	-	
	72	67.6	4.2	45.5	39.3	33.0	26.8	-	-	65.4	4.7	44.8	38.5	32.1	25.7	-	-	
	67	63.6	4.2	56.4	50.2	43.9	37.7	31.4	-	60.8	4.7	55.8	49.4	43.0	36.6	30.3	-	
	62	59.5	4.2	59.5	59.5	54.4	48.9	41.9	35.6	56.4	4.6	56.4	56.4	53.0	46.6	40.2	33.9	
	57	57.1	4.2	57.1	57.1	58.0	52.8	45.5	39.3	54.4	4.7	54.4	54.4	55.6	49.2	42.8	36.5	
1900	72	68.1	4.3	45.7	39.4	33.1	26.8	-	-	65.7	4.7	45.2	38.7	32.2	25.7	-	-	
	67	64.1	4.2	56.7	50.4	44.1	37.8	31.5	-	61.1	4.7	56.1	49.6	43.1	36.7	30.2	-	
	62	60.0	4.3	60.0	60.0	54.5	48.6	41.9	35.6	56.7	4.7	56.7	56.7	53.1	46.7	40.2	33.7	
	57	57.5	4.3	57.5	57.5	58.0	52.2	45.4	39.1	54.7	4.7	54.7	54.7	55.2	48.8	42.3	35.8	
	72	68.7	4.3	45.9	39.5	33.2	26.8	-	-	66.0	4.8	45.5	38.9	32.3	25.7	-	-	
1950	67	64.6	4.3	56.9	50.5	44.2	37.8	31.5	-	61.4	4.8	56.5	49.9	43.3	36.7	30.1	-	
	62	60.4	4.3	60.4	60.4	54.7	48.3	42.0	35.7	57.0	4.7	57.0	57.0	53.3	46.7	40.1	33.5	
	57	58.0	4.3	58.0	58.0	58.0	51.6	45.3	38.9	54.9	4.7	54.9	54.9	54.9	48.3	41.7	35.1	
					95°F							105°F						
	1500	77	65.5	5.0	29.0	23.4	17.8	-	-	-	62.8	5.6	28.3	22.7	17.1	-	-	-
72		60.5	5.0	38.7	33.1	27.5	21.9	-	-	57.4	5.6	37.6	32.0	26.4	20.8	-	-	
67		55.5	5.0	48.3	42.7	37.1	31.5	25.9	-	51.9	5.5	46.9	41.3	35.7	30.1	24.5	-	
62		51.1	4.9	51.1	51.1	45.5	39.9	34.3	28.7	47.7	5.4	47.7	47.7	43.8	38.2	32.5	26.9	
57		49.5	5.0	49.5	49.5	46.8	41.2	35.6	30.0	46.7	5.5	46.7	46.7	44.0	38.4	32.7	27.1	
1675	77	66.9	5.1	31.2	25.1	19.1	-	-	-	64.1	5.7	31.1	24.4	18.3	-	-	-	
	72	61.8	5.1	41.4	35.4	29.3	23.3	-	-	58.6	5.7	40.5	34.3	28.2	22.1	-	-	
	67	56.8	5.1	51.7	45.7	39.6	33.6	27.5	-	53.0	5.6	49.8	44.3	38.1	32.0	25.9	-	
	62	52.2	5.0	52.2	52.2	48.5	42.1	36.4	30.4	48.7	5.5	48.7	48.7	46.8	40.4	34.5	28.3	
	57	50.6	5.0	50.6	50.6	50.0	43.4	37.9	31.8	47.7	5.6	47.7	47.7	47.0	40.6	34.7	28.6	
1850	77	68.4	5.2	33.3	26.8	20.3	-	-	-	65.5	5.8	33.9	26.1	19.4	-	-	-	
	72	63.2	5.2	44.2	37.7	31.2	24.7	-	-	59.8	5.7	43.3	36.7	30.0	23.3	-	-	
	67	58.0	5.2	55.1	48.6	42.1	35.6	29.1	-	54.1	5.7	52.7	47.2	40.6	33.9	27.3	-	
	62	53.4	5.1	53.4	53.4	51.6	44.3	38.6	32.1	49.7	5.6	49.7	49.7	49.7	42.7	36.4	29.8	
	57	51.7	5.1	51.7	51.7	53.1	45.6	40.1	33.6	48.6	5.6	48.6	48.6	50.0	42.8	36.7	30.0	
1900	72	63.3	5.2	44.6	38.0	31.3	24.6	-	-	59.8	5.8	43.8	37.0	30.2	23.4	-	-	
	67	58.1	5.2	55.6	48.9	42.2	35.5	28.9	-	54.2	5.7	52.9	47.6	40.8	34.0	27.2	-	
	62	53.4	5.1	53.4	53.4	51.8	44.7	38.4	31.7	49.8	5.6	49.8	49.8	49.4	42.4	35.7	28.9	
	57	51.8	5.1	51.8	51.8	52.5	45.3	39.1	32.4	48.7	5.7	48.7	48.7	49.3	42.3	35.7	28.9	
	72	63.4	5.2	45.1	38.2	31.4	24.5	-	-	59.8	5.8	44.3	37.3	30.4	23.4	-	-	
1950	67	58.2	5.2	56.1	49.2	42.4	35.5	28.6	-	54.2	5.8	53.2	48.0	41.1	34.1	27.1	-	
	62	53.5	5.1	53.5	53.5	51.9	45.1	38.2	31.3	49.8	5.7	49.8	49.8	49.0	42.0	35.1	28.1	
	57	51.9	5.2	51.9	51.9	51.9	45.0	38.1	31.2	48.7	5.7	48.7	48.7	48.7	41.7	34.7	27.8	

TABLE 8: COOLING CAPACITIES - 5 TON (ACP060) (CONTINUED)

Air on Evaporator Coil		Temperature of Air on Condenser Coil															
CFM	WB (°F)	Total Capacity ¹ (MBh)	Total Input (kW) ²	Sensible Capacity (MBh)						Total Capacity ¹ (MBh)	Total Input (kW) ²	Sensible Capacity (MBh)					
				Return Dry Bulb (°F)								Return Dry Bulb (°F)					
				90	85	80	75	70	65			90	85	80	75	70	65
				115°F						125°F							
1500	77	60.2	6.2	27.6	22.0	16.3	-	-	-	57.5	6.8	26.9	21.2	15.6	-	-	-
	72	54.3	6.2	36.6	31.0	25.3	19.7	-	-	51.1	6.7	35.6	29.9	24.2	18.6	-	-
	67	48.4	6.1	45.6	39.9	34.3	28.7	23.0	-	44.8	6.6	44.2	38.6	32.9	27.2	21.6	-
	62	44.4	6.0	44.4	44.4	42.1	36.4	30.8	25.2	41.0	6.5	41.0	41.0	40.4	34.7	29.0	23.4
	57	43.8	6.0	43.8	43.8	41.1	35.5	29.9	24.2	41.0	6.6	41.0	41.0	38.3	32.6	27.0	21.3
1675	77	61.4	6.3	31.1	23.7	17.5	-	-	-	58.6	6.9	31.1	23.0	16.7	-	-	-
	72	55.3	6.2	39.5	33.3	27.1	20.8	-	-	52.1	6.8	38.6	32.2	25.9	19.6	-	-
	67	49.3	6.2	47.9	42.9	36.7	30.4	24.2	-	45.6	6.7	45.6	41.5	35.2	28.9	22.6	-
	62	45.2	6.1	45.2	45.2	45.0	38.7	32.5	26.3	41.8	6.6	41.8	41.8	41.8	37.1	30.6	24.2
	57	44.7	6.1	44.7	44.7	44.0	37.7	31.5	25.3	41.7	6.6	41.7	41.7	41.0	34.9	28.3	22.0
1850	77	62.5	6.4	34.6	25.4	18.6	-	-	-	59.6	7.0	35.3	24.7	17.8	-	-	-
	72	56.4	6.3	42.4	35.6	28.8	22.0	-	-	53.0	6.9	41.6	34.6	27.6	20.7	-	-
	67	50.3	6.2	50.3	45.8	39.0	32.2	25.4	-	46.4	6.8	46.4	44.5	37.5	30.5	23.6	-
	62	46.1	6.1	46.1	46.1	47.9	41.1	34.2	27.4	42.5	6.7	42.5	42.5	42.5	39.4	32.1	25.1
	57	45.6	6.2	45.6	45.6	46.8	40.0	33.2	26.4	42.5	6.7	42.5	42.5	42.5	37.2	29.7	22.7
1900	72	56.4	6.3	42.9	36.0	29.1	22.1	-	-	52.9	6.9	42.1	35.0	28.0	20.9	-	-
	67	50.2	6.3	50.2	46.3	39.4	32.5	25.5	-	46.3	6.8	46.3	45.0	38.0	30.9	23.9	-
	62	46.1	6.2	46.1	46.1	47.0	40.0	33.1	26.2	42.4	6.7	42.4	42.4	42.4	37.7	30.4	23.4
	57	45.5	6.2	45.5	45.5	46.1	39.2	32.3	25.3	42.4	6.8	42.4	42.4	42.4	36.2	28.9	21.8
1950	72	56.3	6.4	43.5	36.4	29.3	22.3	-	-	52.8	7.0	42.6	35.5	28.3	21.2	-	-
	67	50.2	6.3	50.2	46.8	39.7	32.7	25.6	-	46.2	6.9	46.2	45.6	38.4	31.3	24.1	-
	62	46.1	6.2	46.1	46.1	46.1	39.0	31.9	24.9	42.3	6.7	42.3	42.3	42.3	36.0	28.8	21.7
	57	45.5	6.3	45.5	45.5	45.5	38.4	31.4	24.3	42.3	6.8	42.3	42.3	42.3	35.2	28.0	20.8

1. These capacities are Net Capacities.
2. These ratings include the compressor, condenser fan and supply air blower motors.

TABLE 9: SIDE AND BOTTOM SUPPLY AIR BLOWER PERFORMANCE

Model No. ACP	Blower Speed Setting	External Static Pressure (Inches Water Gauge)														
		0.2			0.4			0.6			0.8			1.0		
		CFM	W	RPM	CFM	W	RPM	CFM	W	RPM	CFM	W	RPM	CFM	W	RPM
024 (2.0)	Low (1)	726	87	632	629	99	739	-	-	-	-	-	-	-	-	-
	Low/Medium (2)	768	97	651	679	110	754	-	-	-	-	-	-	-	-	-
	Medium (3)	883	131	704	812	147	797	736	162	889	651	177	979	-	-	-
	Medium/High (4)	990	170	755	934	187	839	868	202	920	791	216	1000	696	227	1078
	High (5)	-	-	-	-	-	-	985	245	952	913	257	1022	813	261	1090
030 (2.5)	Low (1)	844	119	686	767	133	782	-	-	-	-	-	-	-	-	-
	Low/Medium (2)	1003	175	762	949	192	844	884	208	925	808	222	1003	-	-	-
	Medium (3)	1068	204	795	1020	221	871	961	236	945	888	248	1018	790	254	1087
	Medium/High (4)	1180	264	855	1140	279	920	1086	291	983	1015	299	1045	904	292	1102
	High (5)	-	-	-	-	-	-	1212	367	1032	1138	366	1080	997	336	1123
036 (3.0)	Low (1)	982	164	749	924	183	835	-	-	-	-	-	-	-	-	-
	Low/Medium (2)	1004	174	761	949	193	845	-	-	-	-	-	-	-	-	-
	Medium (3)	1277	332	912	1235	347	970	1186	360	1028	1125	368	1086	1007	352	1147
	Medium/High (4)	1351	401	960	1310	410	1009	1261	415	1058	1198	414	1107	1064	381	1150
	High (5)	1411	473	1002	1368	473	1044	1316	469	1084	1247	457	1122	1083	400	1142
042 (3.5)	Low (1)	1154	217	763	1068	228	802	-	-	-	-	-	-	-	-	-
	Low/Medium (2)	1288	267	769	1196	279	804	1102	315	911	-	-	-	-	-	-
	Medium (3)	1512	388	812	1416	401	842	1314	436	932	1206	454	993	1083	460	1051
	Medium/High (4)	1672	518	878	1578	530	905	1476	559	984	1359	564	1034	1209	538	1078
	High (5)	-	-	-	1729	693	1110	1630	710	1071	1507	693	1110	1322	615	1133
048 (4.0)	Low (1)	1316	235	707	1222	260	780	-	-	-	-	-	-	-	-	-
	Low/Medium (2)	1521	348	788	1436	373	849	1353	399	913	1272	426	978	-	-	-
	Medium (3)	1705	476	858	1624	501	911	1545	526	966	1466	549	1021	1386	571	1077
	Medium/High (4)	1806	561	895	1726	587	945	1646	610	995	1564	628	1046	1476	639	1096
	High (5)	1898	652	929	1819	679	977	1736	698	1023	1646	709	1069	1547	706	1112
060 (5.0)	Low (1)	1580	394	859	1504	420	917	-	-	-	-	-	-	-	-	-
	Low/Medium (2)	1854	605	972	1783	446	931	1703	646	1065	1605	648	1104	-	-	-
	Medium (3)	2003	737	1030	1922	584	999	1829	746	1104	1712	728	1134	1528	659	1146
	Medium/High (4)	2120	856	1073	2021	746	1069	1908	815	1127	1769	772	1148	1567	685	1154
	High (5)	2214	968	1104	2089	918	1121	1949	859	1136	1785	787	1148	1576	689	1154

TABLE 10: ADDITIONAL STATIC RESISTANCE

Size (Tons)	CFM	Wet Indoor Coil	Economizer ¹	Filter/Frame Kit	Electric Heat
024 (2.0)	500	0.01	0.00	0.01	0.02
	600	0.01	0.00	0.02	0.03
	700	0.01	0.00	0.02	0.03
	800	0.01	0.01	0.02	0.03
	900	0.01	0.01	0.02	0.04
	1000	0.02	0.01	0.02	0.04
	1100	0.03	0.01	0.03	0.05
030 (2.5)	1200	0.04	0.02	0.03	0.06
	700	0.01	0.00	0.02	0.03
	800	0.01	0.01	0.02	0.03
	900	0.01	0.01	0.02	0.04
	1000	0.02	0.01	0.02	0.04
	1100	0.03	0.01	0.03	0.05
036 (3.0)	1200	0.04	0.02	0.03	0.06
	1300	0.07	0.03	0.17	-
	700	0.01	0.00	0.02	0.03
	800	0.01	0.01	0.02	0.03
	900	0.01	0.01	0.02	0.04
	1000	0.02	0.01	0.02	0.04
	1100	0.03	0.01	0.03	0.05
	1200	0.04	0.02	0.03	0.06
042 (3.5)	1300	0.04	0.03	0.03	0.07
	1400	0.04	0.04	0.03	0.08
	1100	0.03	0.01	0.03	0.05
	1200	0.04	0.02	0.03	0.06
	1300	0.04	0.03	0.03	0.07
	1400	0.04	0.04	0.03	0.08
	1500	0.04	0.05	0.04	0.09
	1600	0.04	0.06	0.05	0.10
	1700	0.05	0.07	0.05	0.11
	1800	0.05	0.07	0.06	0.11
048 (4.0)	1900	0.06	0.08	0.06	0.11
	2000	0.07	0.08	0.07	0.12
	1100	0.03	0.01	0.03	0.05
	1200	0.04	0.02	0.03	0.06
	1300	0.04	0.03	0.03	0.07
	1400	0.04	0.04	0.03	0.08
	1500	0.04	0.05	0.04	0.09
	1600	0.04	0.06	0.05	0.10
	1700	0.05	0.07	0.05	0.11
	1800	0.05	0.07	0.06	0.11
060 (5.0)	1900	0.06	0.08	0.06	0.11
	2000	0.07	0.08	0.07	0.12
	1100	0.03	0.01	0.03	0.05
	1200	0.04	0.02	0.03	0.06
	1300	0.04	0.03	0.03	0.07
	1400	0.04	0.04	0.03	0.08
	1500	0.04	0.05	0.04	0.09
	1600	0.04	0.06	0.05	0.10
	1700	0.05	0.07	0.05	0.11
	1800	0.05	0.07	0.06	0.11

1. The pressure drop through the economizer is greater for 100% outdoor air than for 100% return air. If the resistance of the return air duct is less than 0.25 IWG, the unit will deliver less CFM during full economizer operation.

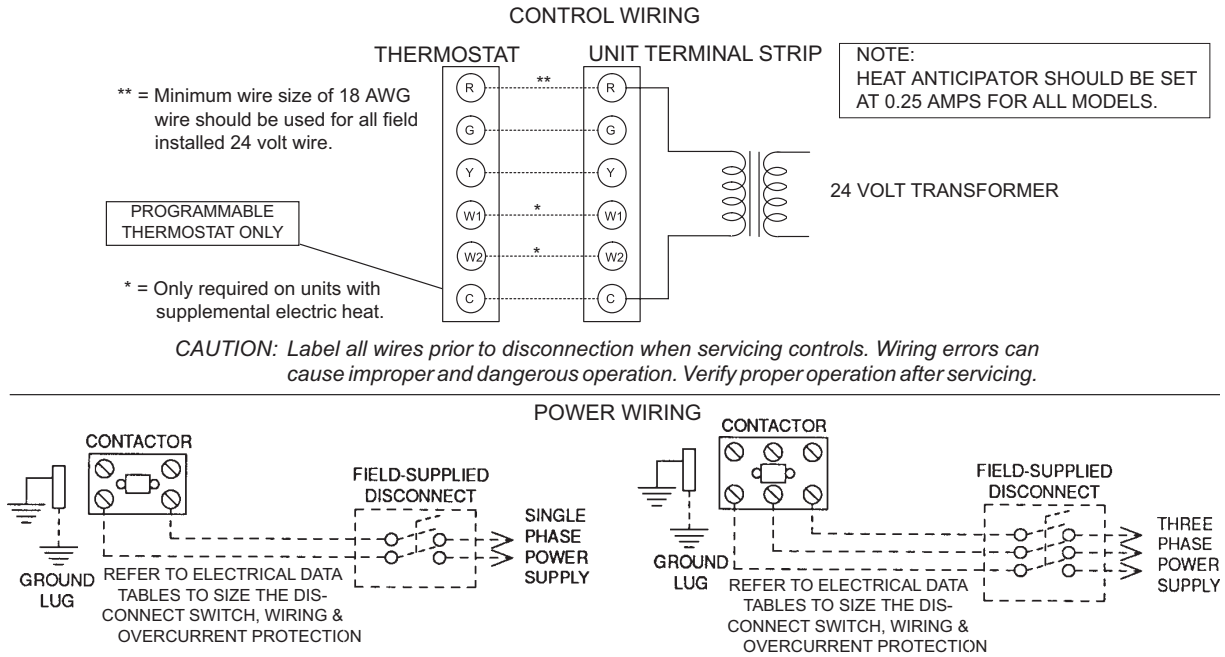

FIGURE 2 - TYPICAL FIELD WIRING DIAGRAM

TABLE 11: ACP024-060 ELECTRICAL DATA / ELECTRIC HEAT

Size (Tons)	Volt	Compressors (each)			OD Fan Motors (each) FLA	Supply Blower Motor FLA	Electric Heat Option				MCA ¹ (Amps)	Max Fuse ² / Breaker ³ Size (Amps)
		RLA	LRA	MCC			Model	kW	Stages	Amps		
024 (2.0)	208/230-1-60	10.0	55	16	1.2	4.1	None	-	-	-	17.8	25
							2NH04500506	3.8 / 5	1	18.3 / 20.8	28 / 31.2	30 / 35
							2NH04500706	5.6 / 7.5	2	26.9 / 31.3	38.8 / 44.2	40 / 45
							2NH04501006	7.5 / 10	2	36.1 / 41.7	50.2 / 57.2	60 / 60
030 (2.5)	208/230-1-60	10.9	68	17.1	1.2	4.1	None	-	-	-	18.9	25
							2NH04500506	3.8 / 5	1	18.3 / 20.8	27.7 / 31.2	30 / 35
							2NH04500706	5.6 / 7.5	2	26.9 / 31.3	39 / 44.2	40 / 45
							2NH04501006	7.5 / 10	2	36.1 / 41.7	50.2 / 57.2	60 / 60
036 (3.0)	208/230-1-60	12.8	78	20	1.2	4.1	None	-	-	-	21.3	30
							2NH04500506	3.8 / 5	1	18.3 / 20.8	28 / 31.2	30 / 35
							2NH04500706	5.6 / 7.5	2	26.9 / 31.3	38.8 / 44.2	40 / 45
							2NH04501006	7.5 / 10	2	36.1 / 41.7	50.2 / 57.2	60 / 60
	208/230-3-60	9.0	72	14	1.2	4.1	None	-	-	-	16.6	20
							2NH04501025	7.5 / 10	1	20.8 / 24.1	31.1 / 35.2	35 / 40
							2NH04501525	11.3 / 15	1	31.4 / 36.1	44.3 / 50.2	45 / 60
							None	-	-	-	10.1	15
460-3-60	5.8	45	9	0.8	2.1	2NH04501046	10	1	12	17.6	20	
						2NH04501546	15	1	18	25.1	30	
						None	-	-	-	11.8	15	
042 (3.5)	208/230-1-60	21.1	115	33	1.2	6.0	None	-	-	-	33.6	45
							2NH04500506	3.8 / 5	1	18.3 / 20.8	33.6 / 33.6	45 / 45
							2NH04500706	5.6 / 7.5	2	26.9 / 31.3	41.2 / 46.6	50 / 50
							2NH04501006	7.5 / 10	2	36.1 / 41.7	52.6 / 59.6	60 / 60
	208/230-3-60	13.4	89	21	1.2	6.0	None	-	-	-	24	30
							2NH04501025	7.5 / 10	1	20.8 / 24.1	33.5 / 37.6	35 / 40
							2NH04501525	11.3 / 15	1	31.4 / 36.1	46.7 / 52.6	50 / 60
							None	-	-	-	11.8	15
	460-3-60	6.4	45	10	0.8	3.0	2NH04501046	10	1	12	18.8	20
							2NH04501546	15	1	18	26.3	30
None							-	-	-	12.5	15	
048 (4.0)	208/230-1-60	21.1	115	33	1.2	6.0	None	-	-	-	33.6	45
							2NH04501006	7.5 / 10	2	36.1 / 41.7	52.6 / 59.6	60 / 60
							2NH04501506	11.3 / 15	2	54.3 / 62.5	75.4 / 85.6	80 / 90
							2NH04502006	15 / 20	2	72.1 / 83.3	97.6 / 111.7	100 / 125
	208/230-3-60	14.1	95	22	1.2	6.0	2NH04502506	18.8 / 25	2	90.4 / 104.2	120.5 / 137.7	125 / 150
							None	-	-	-	24.8	30
							2NH04501025	7.5 / 10	1	20.8 / 24.1	33.5 / 37.6	35 / 40
							2NH04501525	11.3 / 15	1	31.4 / 36.1	46.7 / 52.6	50 / 60
	460-3-60	7.0	45	11	0.8	3.0	2NH04502025	15 / 20	2	41.6 / 48.1	59.5 / 67.6	60 / 70
							2NH04502525	18.8 / 25	2	52.2 / 60.1	72.7 / 82.7	80 / 90
							None	-	-	-	12.5	15
							2NH04501046	10	1	12	18.8	20
							2NH04501546	15	1	18	26.3	30
460-3-60	7.0	45	11	0.8	3.0	2NH04502046	20	2	24.1	33.8	35	
						2NH04502546	25	2	30.1	41.3	45	

TABLE 11: ACP024-060 ELECTRICAL DATA / ELECTRIC HEAT (CONTINUED)

Size (Tons)	Volt	Compressors (each)			OD Fan Motors (each)	Supply Blower Motor FLA	Electric Heat Option				MCA ¹ (Amps)	Max Fuse ² / Breaker ³ Size (Amps)
		RLA	LRA	MCC			FLA	Model	kW	Stages		
060 (5.0)	208/230-1-60	25.0	150	39	2.3	7.6	None	-	-	-	41.2	50
							2NH04501006	7.5 / 10	2	36.1 / 41.7	54.6 / 61.6	60 / 70
							2NH04501506	11.3 / 15	2	54.2 / 62.5	77.2 / 87.6	80 / 90
							2NH04502006	15 / 20	2	72.2 / 83.3	99.8 / 113.7	100 / 125
	208/230-3-60	17.3	123	27	2.3	7.6	2NH04502506	18.8 / 25	2	90.3 / 104.2	122.3 / 139.7	125 / 150
							None	-	-	-	31.5	40
							2NH04501025	7.5 / 10	1	20.8 / 24.1	35.6 / 39.6	45 / 45
							2NH04501525	11.3 / 15	1	31.3 / 36.1	48.6 / 54.6	50 / 60
	460-3-60	8.4	70	13	1.3	3.8	2NH04502025	15 / 20	2	41.7 / 48.1	61.6 / 69.6	70 / 70
							2NH04502525	18.8 / 25	2	52.1 / 60.1	74.7 / 84.7	80 / 90
							None	-	-	-	15.6	20
							2NH04501046	10	1	12	19.8	20
	460-3-60	8.4	70	13	1.3	3.8	2NH04501546	15	1	18	27.3	30
							2NH04502046	20	2	24.1	34.8	35
							2NH04502546	25	2	30.1	42.3	45

1. Minimum Circuit Ampacity.
2. Maximum Over Current Protection per standard UL 1995.
3. Fuse or HACR circuit breaker size installed at factory or field installed.

TABLE 12: UNIT WEIGHTS

Unit Size	Shipping Weight	Operating Weight	Corner Weights				Economizer (lbs.)	Roof Curb (lbs.)
			A	B	C	D		
024	338	333	91	80	78	88	40	8" - 70 14" - 75
030	340	335	86	83	83	87		
036	360	360	96	84	81	93		
042	348	343	94	83	80	91		
048	384	379	103	90	87	99		
060	500	495	135	117	113	130		

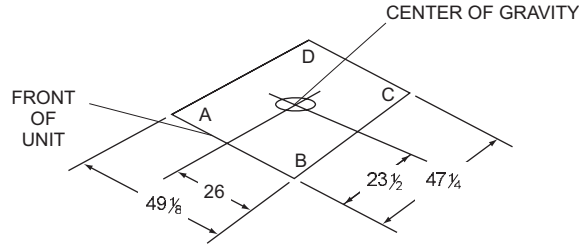

FIGURE 4 - CENTER OF GRAVITY

TABLE 13: CLEARANCES

Unit Clearances (Minimum)	
Front	12"
Back	0"
Left Side (Filter Access)	24"
Right Side	24"
Below Unit ¹	0"
Above Unit ²	36" (For Condenser Air Discharge)

1. Units may be installed on combustible floors made from wood or class A, B or C roof covering material.
2. Units must be installed outdoors. Overhanging structures or shrubs should not obstruct outdoor air discharge outlet.

NOTE: For units applied with a roof curb, the minimum clearance may be reduced from 1 inch to 1/2 inch

between combustible roof curb material and the supply duct.

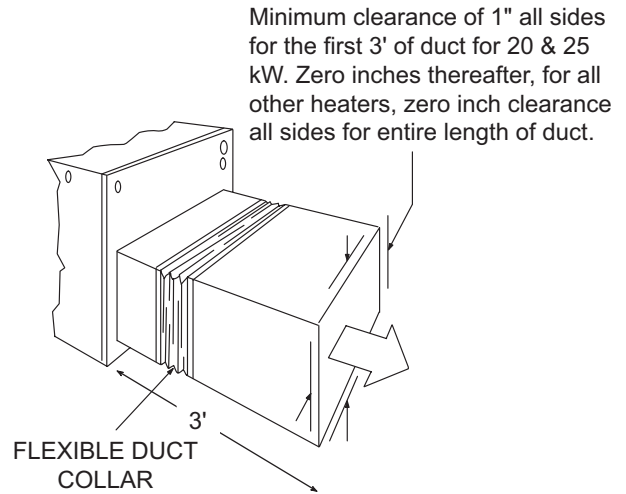

TYPICAL APPLICATIONS

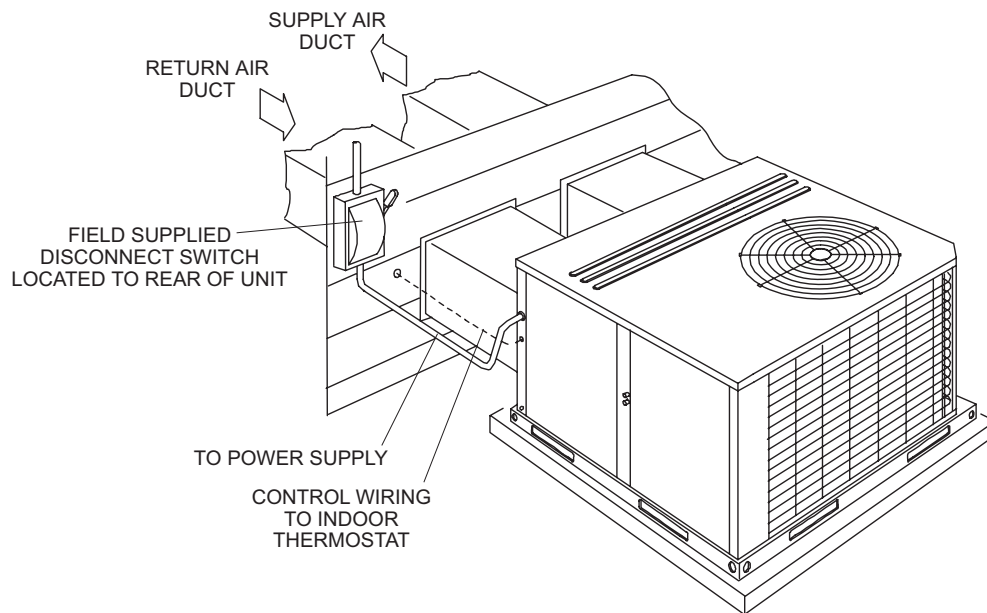

FIGURE 5 - TYPICAL SLAB ON GROUND INSTALLATION

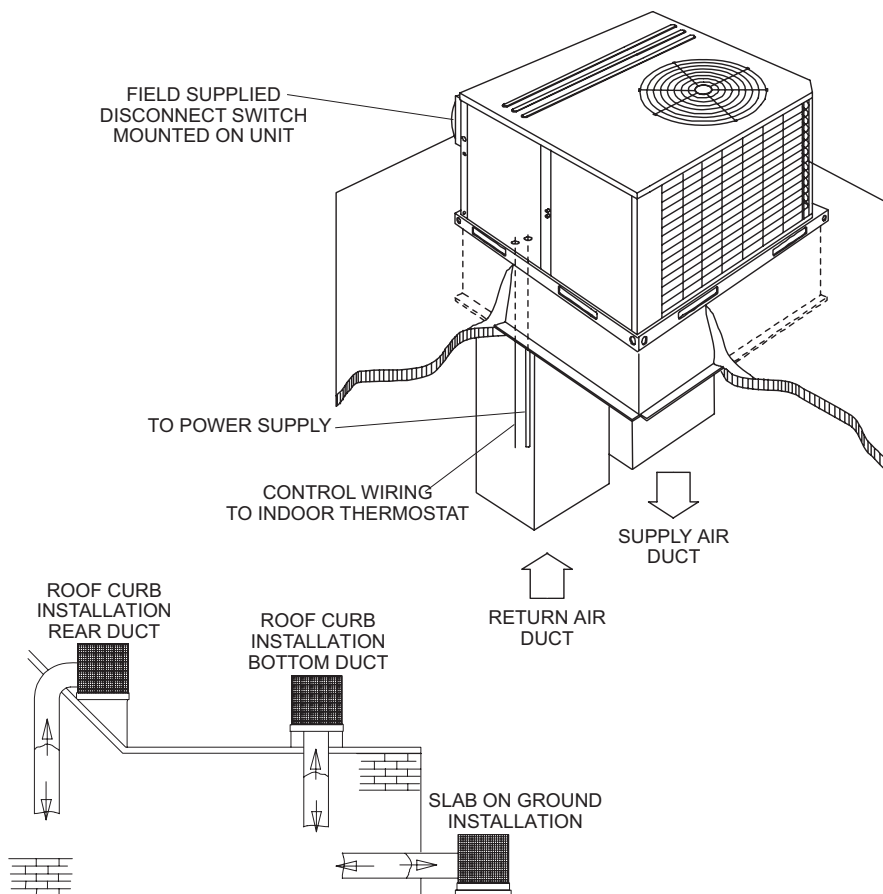
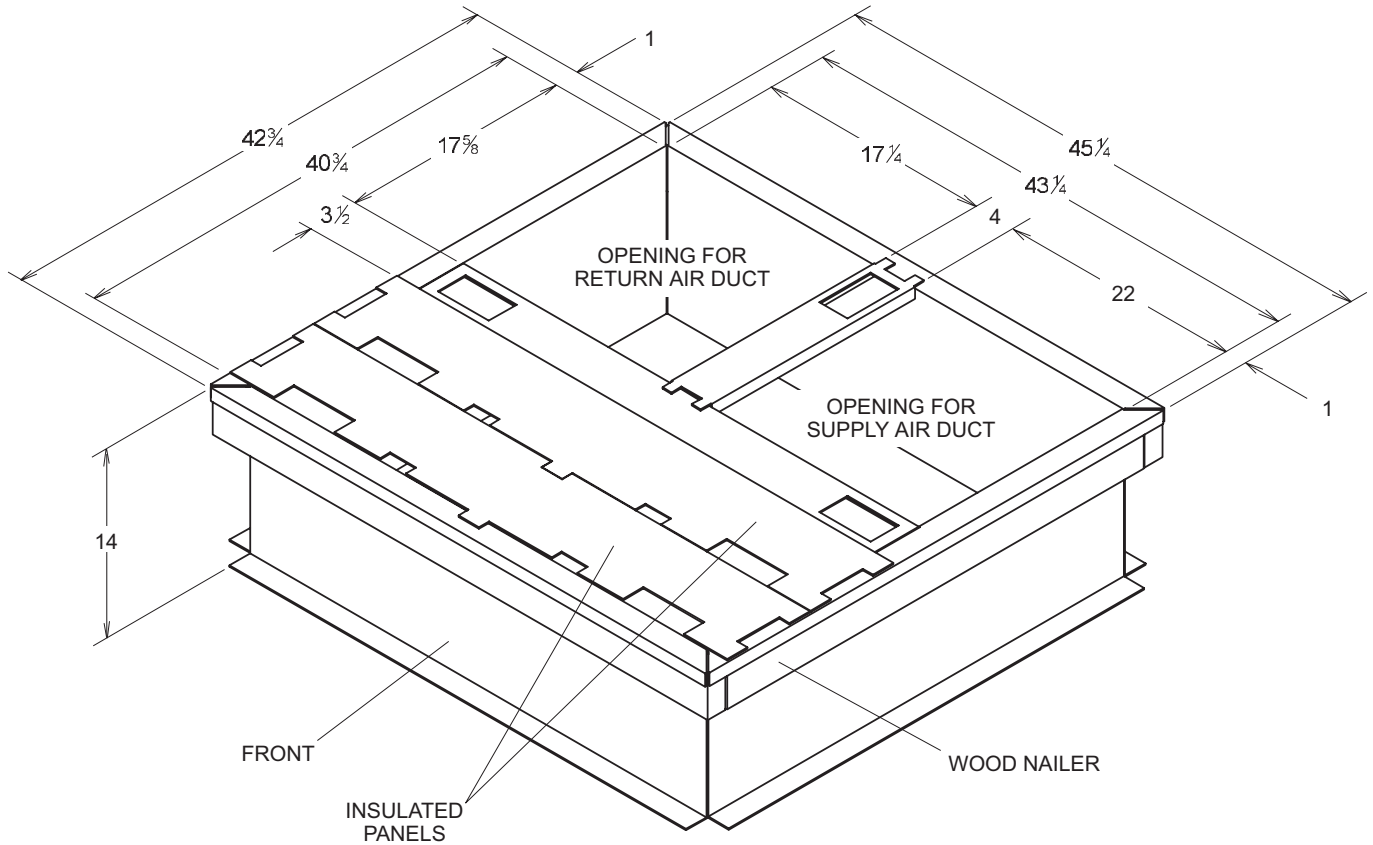

FIGURE 6 - TYPICAL ROOF CURB INSTALLATION



RECOMMENDED DUCT SIZE	
SUPPLY AIR DUCT	17 1/8" x 21 1/2"
RETURN AIR DUCT	17 1/8" x 16 3/4"

FIGURE 7 - ROOF CURB DIMENSIONS (8" Roof curb also available)

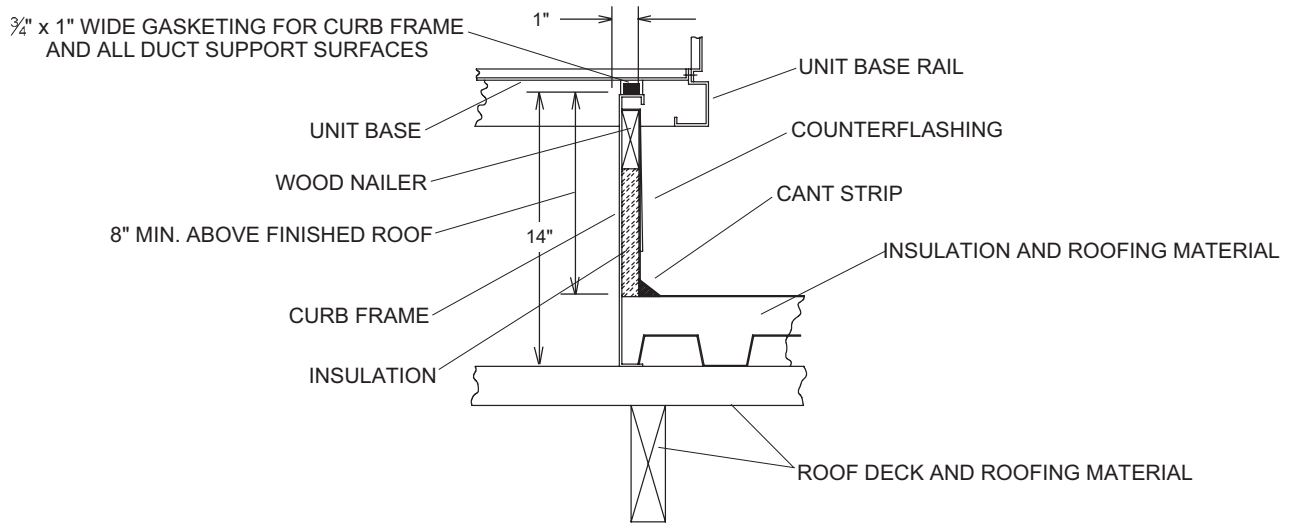

FIGURE 8 - ROOF CURB APPLICATION

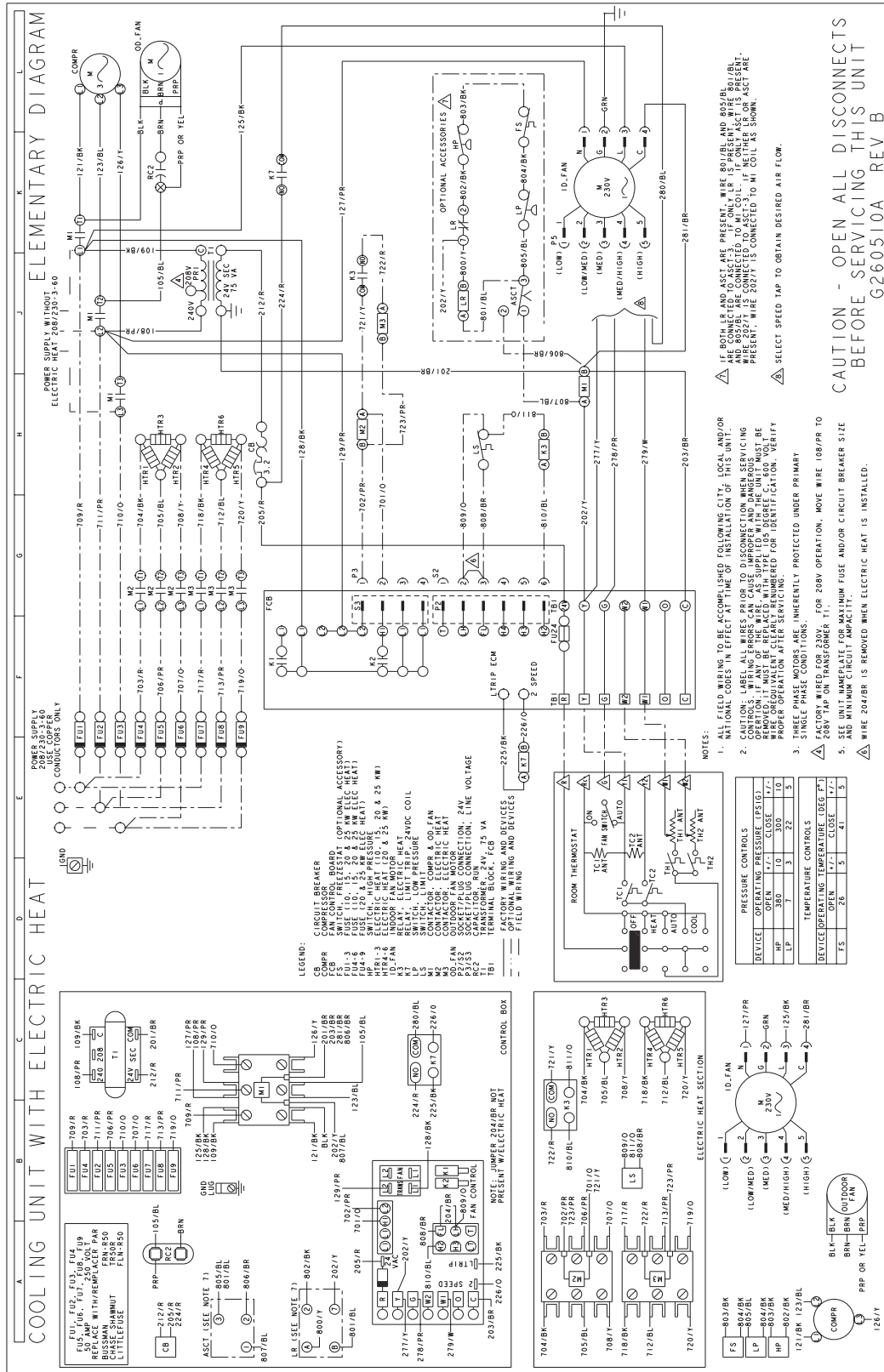

FIGURE 10 - TYPICAL WIRING DIAGRAM (208/230-3-60 POWER SUPPLY) ACP MODELS

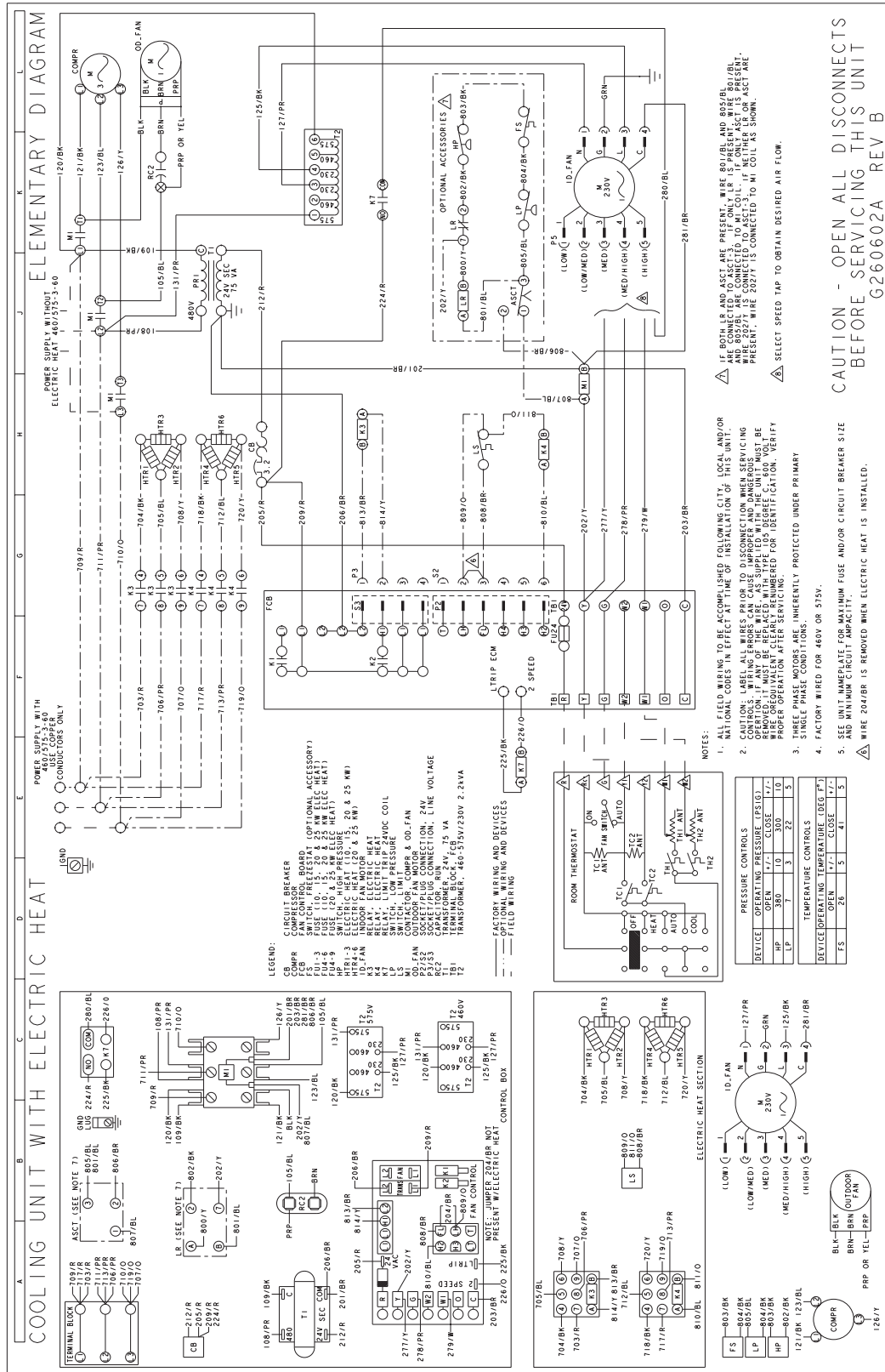

FIGURE 11 - TYPICAL WIRING DIAGRAM (460-3-60 POWER SUPPLY) ACP MODELS

MECHANICAL SPECIFICATIONS

GENERAL DESCRIPTION

Units shall be factory-assembled, single packaged, Electric Cooling units, designed for outdoor mounted installation. ACP units shall have minimum SEER ratings of 13. They shall have built in, equal size, field convertible duct connections for down discharge supply/return or horizontal discharge supply/return.

The units shall be factory wired, piped, charged with R-22 refrigerant and factory tested prior to shipment. All unit wiring shall be both numbered and color coded.

All units shall be manufactured in a facility certified to ISO 9001 standards, and the cooling performance shall be rated in accordance with DOE and ARI test procedures. Units shall be certified to UL 1995/CAN/CSA C22.2 No. 236 standard.

UNIT CABINET

1. Unit cabinet shall be constructed of galvanized steel, with exterior surfaces coated with a non-chalking, powered paint finish, certified at 1000 hours salt spray test per ASTM-B117 standards.
2. The unit top shall be a single piece "Water Shed" design, with drip edges and no-seam corners to provide optimum water integrity.
3. Unit shall have a rigidly mounted condenser coil guard to provide protection from objects and personnel after installation.
4. Indoor blower section shall be insulated with up to 3/4" thick, aluminum, foil faced insulation, fastened to prevent insulation from entering the air stream.
5. Cabinet panels shall be "large" size, easily removable for servicing and maintenance, with built-in lift handles.
6. Unit shall be built on a formed, "Super-Structure" design base pan, with embossments at critical points to add strength, rigidity and aid in minimizing sound.
7. Full perimeter base rails shall be provided to assure reliable transit of equipment, overhead rigging, fork truck access and proper sealing on roof curb applications. Base rails shall be removable, when required, to lower unit height.
8. Filters shall be furnished and be accessible through a removable access door, sealed air tight. (Single phase models - accessory kit available. Three phase models - standard from factory.)
9. Units vertical discharge and return duct configuration shall be designed to fit between standard 24" O.C. beams without modification to building structure, duct work and base unit.
10. Condensate pan shall be internally sloped and conform to ASHARE 62-89 self-draining standards, with 3/4" NPTI copper, ridged mount connection.

INDOOR (EVAPORATOR) FAN ASSEMBLY

1. The ACP fan motor shall be direct drive, 5 speed design.
2. Fan wheel shall be double-inlet type with forward-curved blades, dynamically balanced to operate smoothly throughout the entire range of operation. Airflow design shall be constant air volume.
3. Bearings shall be sealed and permanently lubricated for longer life and no maintenance.
4. Fan assembly shall be "Slip Track" (slide-out) design for easy removal and cleaning.

OUTDOOR (CONDENSER) FAN ASSEMBLY

1. The outdoor fan shall be of the direct-driven propeller type, discharge air vertically, have aluminum blades riveted to corrosion resistant steel spider bracket and shall be statically balanced for smooth operation.
2. The outdoor fan motor shall be totally enclosed with permanently lubricated bearings and internally protected against overload conditions.

REFRIGERANT COMPONENTS

1. Compressors:
 - a. Shall be fully hermetic reciprocating type, direct drive, internally protected with internal high-pressure relief and over temperature protection. The hermetic motor shall be suction gas cooled and have a voltage range of + or - 10% of the unit nameplate voltage.
 - b. Shall have internal isolation and sound muffling to minimize vibration and noise, and be externally isolated on a dedicated, independent mounting.
2. Coils:
 - a. Evaporator and condenser coils shall have aluminum plate fins mechanically bonded to seamless internally-enhanced copper tubes with all joints brazed.
 - b. Evaporator and Condenser coils shall be of the direct expansion, draw-thru design.
3. Refrigerant Circuit and Refrigerant Safety Components shall include:
 - a. Independent fixed-orifice or balanced port bi-flow TXV expansion devices.
 - b. Filter/strainer to eliminate any foreign matter.
 - c. Accessible service gage connections on both suction and discharge lines to charge, evacuate, and measure refrigerant pressure during any necessary servicing or troubleshooting, without losing charge and without disrupting condenser or evaporator air flow.
 - d. The refrigeration system shall provide at least 10° F of liquid sub-cooling at design conditions.
4. Unit Controls:

- a. Unit shall contain a large, low voltage Terminal Board for easy connection of field low voltage wiring.
 - b. Controls shall be mounted in a large control box with tilt-out, hinged access door, allowing easy access for trouble shooting and maintenance without affecting the normal system operation pressures.
 - c. Unit shall have large, easily removable panels, covering electrical controls and compressor, allowing easy access for any necessary maintenance or servicing.
3. The heating section assembly shall slide out of the unit for easy maintenance and service.
 4. Units with electric heating sections shall be wired for a single point power supply, with branch circuit fusing (where required).

UNIT OPERATING CHARACTERISTICS

1. Unit shall be capable of starting and running at 125° F outdoor temperature, exceeding maximum load criteria of ARI Standard 210/240.
2. The compressor, with standard controls, shall be capable of operation down to 45° F outdoor temperature. Accessory low ambient kit shall be available for operation to 0° F.

ELECTRICAL REQUIREMENTS

All unit power wiring shall enter unit cabinet at a single factory provided location and be capable of side or bottom entry, to minimize roof penetrations and avoid unit field modifications. Separate side and bottom openings shall be provided for the control wiring.

ELECTRIC HEATING SECTION

1. An electric heating section, with nickel chromium elements, shall be provided in a range of 5 thru 25 KW, offering two stages of capacity - 7 KW and above on single phase heaters, and 20 KW and above on three phase heaters.
2. The heating section shall have a primary limit control(s) and automatic reset, to prevent the heating element system from operating at an excessive temperature.

