

574A –Low NOx Models Available

SINGLE–PACKAGED GAS HEATING/ELECTRIC COOLING UNITS

2 To 5 Nominal Tons



## Product Data

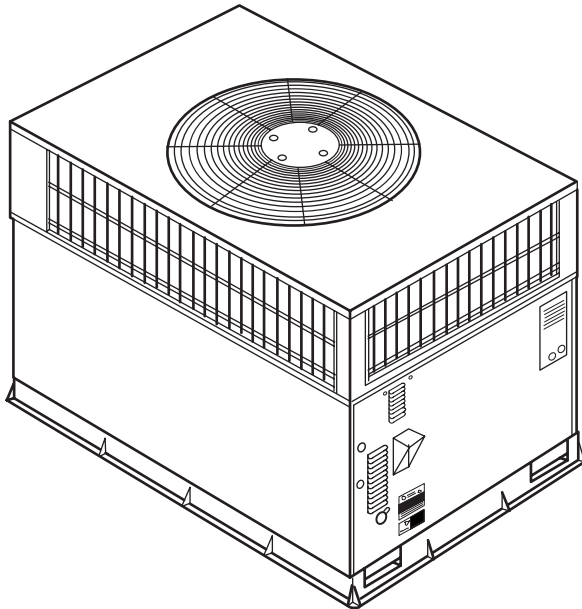

A99338

Unit 574A

Single–Packaged Rooftop Products with Energy–Saving Features.

- Direct Spark Ignition
- Low Sound Levels
- Up to 81% AFUE
- 13 SEER

### FEATURES/BENEFITS

One–piece heating and cooling units with low sound levels, easy installation, low maintenance, and dependable performance.

#### Easy Installation

Factory–assembled package is a compact, fully self–contained, combination gas heating/electric cooling unit that is pre–wired, pre–piped, and pre–charged for minimum installation expense.

These units are available in a variety of standard and optional heating/cooling size combinations with voltage options to meet residential and light commercial requirements. Units are lightweight and install easily on a rooftop or at ground level. The high tech composite basepan eliminates rust problems associated with ground level applications.

#### Convertible duct configuration

Unit is designed for easy use in either downflow or horizontal applications. Each unit is easily converted from horizontal to downflow with the use of the two standard duct covers.

#### Efficient operation

**High–efficiency design** with SEER (Seasonal Energy Efficiency Ratios) of 13.0 and AFUE (Annual Fuel Utilization Efficiency) ratings as high as 81%.

**Energy–saving, direct spark ignition** saves gas by operating only when the room thermostat calls for heating. Standard units are furnished with natural gas controls. A low–cost field–installed kit for propane conversion is available for all units.

**Low NOx units** are designed for California installations. These models meet the Californian maximum oxides of nitrogen (NOx) emissions requirement of 40 nanograms/joule or less as shipped from the factory and **MUST** be installed in California Air Quality Management Districts where a Low NOx rule exists.

#### Durable, dependable components

**Compressors** are designed for high efficiency. Each compressor is hermetically sealed against contamination to help promote longer life and dependable operation. Each compressor also has vibration isolation to provide quieter operation. All compressors have internal high pressure and over-current protection.

**Monoport inshot burners** produce precise air–to–gas mixture, which provides for clean and efficient combustion. The large monoport on the inshot (or injection type) burners seldom, if ever, requires cleaning. All gas furnace components are accessible in one compartment.

**Turbo–tubular™ heat exchangers** are constructed of aluminized steel for corrosion resistance and optimum heat transfer for improved efficiency. The tubular design permits hot gases to make multiple passes across the path of the supply air.

In addition, dimples located on the heat exchanger walls force the hot gases to stay in close contact with the walls, improving heat transfer.

**Direct–drive multi–speed, PSC (permanent split capacitor) blower motor** is standard on all 574A models.

**Direct–drive, PSC condenser–fan motors** are designed to help reduce energy consumption and provide for cooling operation down to 40°F outdoor temperature. Motormaster® II low ambient kit is available as a field–installed accessory.

**Corporate thermostats** include the Time Guard® II anti–short cycle protection circuitry. If an Original Equipment Manufacture (OEM) thermostat is used the Time Guard II field installed anti–short cycle kit must be used.

**Refrigerant system** is designed to provide dependability. Liquid refrigerant strainers are used to promote clean, unrestricted operation. Each unit leaves the factory with a full re-

frigerant charge. Refrigerant service connections make checking operating pressures easier.

**Evaporator and condenser coils** are computer –designed for optimum heat transfer and cooling efficiency. The evaporator coil is fabricated from copper tube and aluminum fins and is located inside the unit for protection against damage. The condenser coil is internally mounted on the top tier of the unit. A FIOP (Factory – Installed Option) metal louvered grille is available on all models. Copper fin coils and pre –coated fin coils are available from the factory by special order. These coils are recommended in applications where aluminum fins are likely to be damaged due to corrosion. They are ideal for seacoast applications.

**Low sound ratings** ensure a quiet indoor and outdoor environment with sound ratings as low as 72dB. (See page 3.)

**Easy to service cabinets** provide easy single –panel accessibility to serviceable components during maintenance and installation. The basepan with integrated drain provides easy ground level installation with or without a mounting pad. Convenient handholds are provided to manipulate the unit on the jobsite. A nesting feature ensures a positive basepan to roof curb seal when the unit is roof mounted. A convenient 3/4 –in. wide perimeter flange makes frame mounting on a rooftop easy.

**Downflow operation** is easily provided in the field to allow vertical ductwork connections. The basepan utilizes knock-out style seals on the bottom openings to ensure a positive seal in the horizontal airflow mode.

**Integrated Gas Control (IGC) board** provides safe and efficient control of heating and simplifies trouble –shooting through its built –in diagnostic function.

**Cabinets** are constructed of heavy –duty, phosphated, zinc –coated prepainted steel capable of withstanding 500 hours in salt spray. Interior surfaces of the evaporator/heat exchanger compartment are insulated with cleanable semi –rigid insulation board, which keeps the conditioned air from being affected by the outdoor ambient temperature and provides improved indoor air quality. (Conforms to American Society of Heating, Refrigeration and Air Conditioning Engineers No. 62P) The sloped drain minimizes standing water in the drains which is provided with an external drain.

MODEL NUMBER NOMENCLATURE

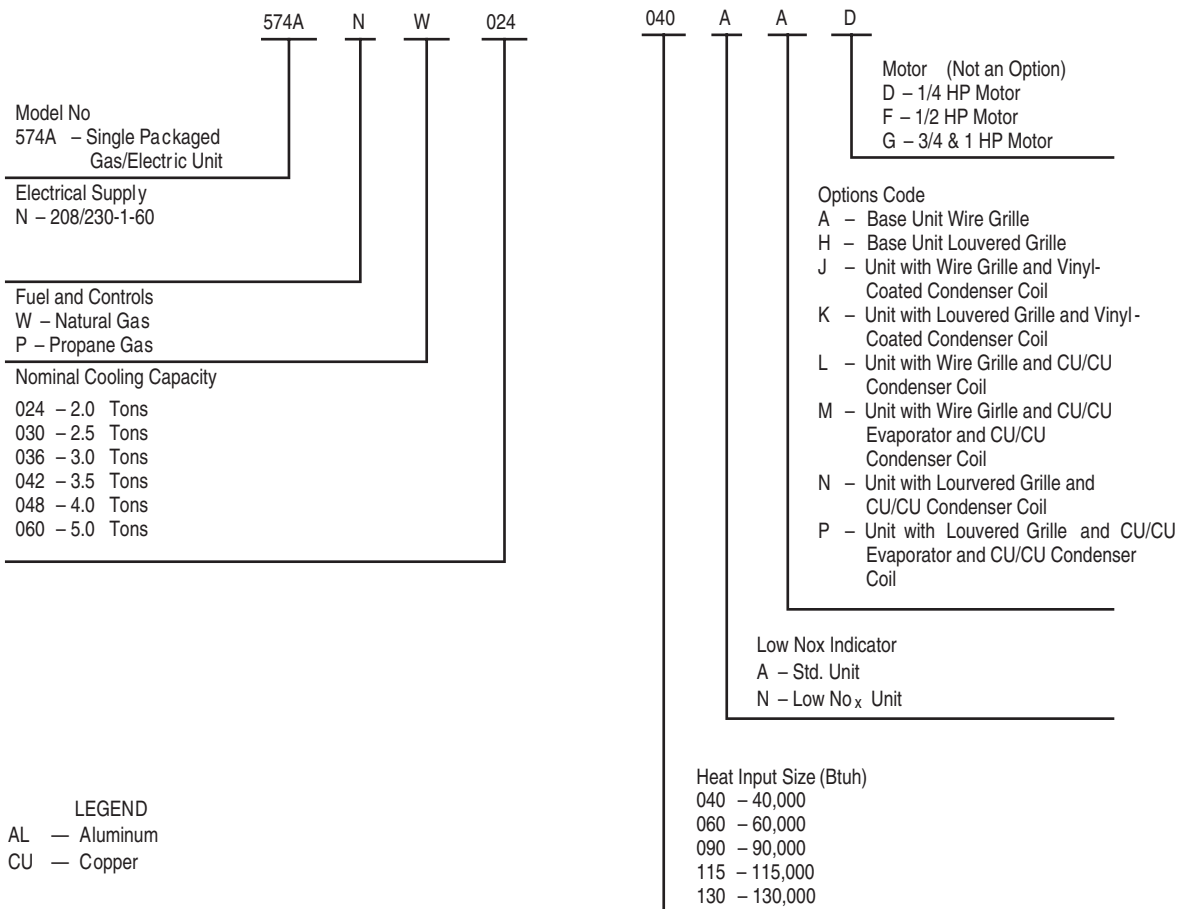

# ARI\* CAPACITIES

## COOLING CAPACITIES AND EFFICIENCIES

UNIT 574A	NOMINAL TONS	STANDARD CFM	NET COOLING CAPACITIES (Btuh)	SEER†	SOUND RATINGS‡ (dB)
024040 024060	2	800	24,000	13.0	72
030040 030060	2-1/2	1000	30,000	13.0	72
036060 036090	3	1200	36,000	13.0	72
042060 042090	3-1/2	1400	41,500	13.0	73
048090 048115 048130	4	1600	47,000	13.0	78
060090 060115 060130	5	1750	57,000	13.0	78

**LEGEND**

db—Dry Bulb

wb—Wet Bulb

SEER—Seasonal Energy Efficiency Ratio

\* Air Conditioning & Refrigeration Institute.

† Rated in accordance with U.S. Government DOE Department of Energy) test procedures and/or ARI Standards 210/240–89.

‡ Tested in accordance with ARI Standard 270–95 (not listed inARI).

**Notes:**

1. Ratings are net values, reflecting the effects of circulating fan heat. Ratings are based on:

Cooling Standard: 80°F db, 67°Fwb indoor entering –air temperature and 95°F db outdoor entering–air temperature.

2. Before purchasing this appliance, read important energy cost and efficiency information available from your retailer.

574A

## HEATING CAPACITIES AND EFFICIENCIES

UNIT 574A	HEATING INPUT (Btuh)	OUTPUT CAPACITY (Btuh)	TEMPERATURE RISE RANGE (°F)	AFUE (%)
024040 030040	40,000	31,000	20-50	80.1 80.1
024060 030060 036060 042060	60,000	46,000 46,000 46,000 47,000	35-65 35-65 25-55 15-45	78.4 78.4 78.7 78.7
036090 042090 048090 060090	88,000 90,000 90,000 90,000	70,000 71,000 70,000 70,000	45-75 35-65 25-55 25-55	79.9 79.9 78.6 78.6
048115 060115	115,000	92,000	35-65	81.1
048130 060130	130,000	104,000 103,000	40-70	80.3

**LEGEND**

AFUE—Annual Fuel Utilization Efficiency

NOTE: Before purchasing this appliance, read important energy cost and efficiency information available from your retailer.

ISO 9001:2000



## OUTDOOR SOUND: OCTAVE BAND DATA—DECIBELS

UNIT	574A					
	024	030	036	042	048	060
Frequency (Hz)						
125	54.1	47.3	56.4	56.9	64.0	64.1
250	57.1	58.2	61.0	64.0	69.9	66.6
500	64.9	63.2	67.4	68.0	73.3	70.6
1000	67.6	66.1	68.1	67.7	73.5	72.6
2000	64.1	64.0	65.8	64.6	70.4	69.8
4000	59.7	61.3	64.8	61.3	66.7	67.5
8000	53.5	57.0	56.8	55.5	60.5	61.6

**LEGEND**

Sound Levels (10 decibels=1 bel)

# PHYSICAL DATA

574A

UNIT SIZE 574A	024040	024060	030040	30060	036060	036090	042060	042090
<b>NOMINAL CAPACITY (ton)</b>	2	2	2-1/2	2-1/2	3	3	3-1/2	3-1/2
<b>OPERATING WEIGHT (lb)</b>	343	343	366	366	433	433	460	460
<b>COMPRESSORS</b>	Scroll							
<b>REFRIGERANT (R-22) Quantity (lb)</b>	7.8	7.8	8.4	8.4	10.9	10.9	10.9	10.9
<b>REFRIGERANT METERING DEVICE Orifice ID (in.)</b>	Accurater							
	0.065	0.065	0.070	0.070	0.080	0.080	0.088	0.088
<b>CONDENSER COIL</b>								
<b>Rows—Fins/in.</b>	2...21	2...21	2...21	2...21	2...21	2...21	2...21	2...21
<b>Face Area (sq ft)</b>	11.9	11.9	13.6	13.6	15.5	15.5	19.4	19.4
<b>CONDENSER FAN</b>								
<b>Nominal Cfm</b>	2700	2700	2700	2700	2800	2800	2800	2800
<b>Diameter (in.)</b>	22	22	22	22	22	22	22	22
<b>Motor Hp (Rpm)</b>	1/8 (825)	1/8 (825)	1/8 (825)	1/8 (825)	1/8 (825)	1/8 (825)	1/8 (825)	1/8 (825)
<b>EVAPORATOR COIL</b>								
<b>Rows—Fins/in.</b>	3...17	3...17	3...17	3...17	3...17	3...17	3...17	3...17
<b>Face Area (sq ft)</b>	3.7	3.7	3.7	3.7	4.7	4.7	4.7	4.7
<b>EVAPORATOR BLOWER</b>								
<b>Nominal Airflow (Cfm)   Size (in.)</b>	800 10x10 1/3 (1050)	800 10x10 1/3 (1050)	1000 10x10 1/3 (1050)	1000 10x10 1/3 (1050)	1200 11x10 1/2 (1000)	1200 11x10 1/2 (1000)	1400 11x10 1/2 (1075)	1400 11x10 1/2 (1075)
<b>Motor Hp (RPM)</b>								
<b>FURNACE SECTION*</b>								
<b>Burner Orifice No. (Qty—Drill Size)   Natural Gas</b>	2...44	2...38	2...44	2...38	2...38	3...38	2...38	3...38
<b>Burner Orifice No. (Qty—Drill Size)   Liquid Propane</b>	2...50	2...46	2...50	2...46	2...46	3...46	2...46	3...46
<b>RETURN-AIR FILTERS (in.)†   Throwaway</b>	20x24x1	20x24x1	20x24x1	20x24x1	24x36x1	24x36x1	24x36x1	24x36x1

UNIT SIZE 574A	048090	048115	048130	060090	060115	060130
<b>NOMINAL CAPACITY (ton)</b>	4	4	4	5	5	5
<b>OPERATING WEIGHT (lb)</b>	480	480	480	492	492	492
<b>COMPRESSORS</b>	Scroll					
<b>REFRIGERANT (R-22) Quantity (lb)</b>	12.3	12.3	12.3	12.0	12.0	12.0
<b>REFRIGERANT METERING DEVICE Orifice ID (in.)</b>	Accurater					
	0.088	0.088	0.088	0.101	0.101	0.101
<b>CONDENSER COIL</b>						
<b>Rows—Fins/in.</b>	2...21 19.4	2...21 19.4	2...21 19.4	2...21 19.4	2...21 19.4	2...21 19.4
<b>Face Area (sq ft)</b>						
<b>CONDENSER FAN</b>						
<b>Nominal Cfm</b>	3300	3300	3300	3300	3300	3300
<b>Diameter (in.)</b>	22	22	22	22	22	22
<b>Motor Hp (Rpm)</b>	1/4 (1100)	1/4 (1100)	1/4 (1100)	1/4 (1100)	1/4 (1100)	1/4 (1100)
<b>EVAPORATOR COIL</b>						
<b>Rows—Fins/in.</b>	3...17	3...17	3...17	4...17	4...17	4...17
<b>Face Area (sq ft)</b>	5.6	5.6	5.6	5.6	5.6	5.6
<b>EVAPORATOR BLOWER</b>						
<b>Nominal Airflow (Cfm)   Size (in.)</b>	1600 11x10 1/2 (1075)	1600 11x10 1/2 (1075)	1600 11x10 1/2 (1075)	1750 11x10 1 (1040)	1750 11x10 1 (1040)	1750 11x10 1 (1040)
<b>Motor Hp (RPM)</b>						
<b>FURNACE SECTION*</b>						
<b>Burner Orifice No. (Qty—Drill Size)   Natural Gas</b>	3...38	3...33	3...31	3...38	3...33	3...31
<b>Burner Orifice No. (Qty—Drill Size)   Liquid Propane</b>	3...46	3...42	3...41	3...46	3...42	3...41
<b>RETURN-AIR FILTERS (in.)†   Throwaway</b>	24x36x1	24x36x1	24x36x1	24x36x1	24x36x1	24x36x1

**LEGEND**

\* Based on altitude of 0 to 2000 feet.

† Required filter sizes on shown are based on the larger of the ARI (Air Conditioning and Refrigeration Institute) rated cooling airflow or the heating airflow velocity of 300 ft/min for throwaway type or 450 ft/min for high-capacity type. Air filter pressure drop for non-standard filters must not exceed 0.08 in. wg.

# OPTIONS AND ACCESSORIES

## Factory-installed options

**Louvered grille** provides hail and vandalism protection. A wire grille is standard on all models. See model number nomenclature for louvered grille options.

**Coil options** include copper/copper and vinyl-coated construction for refrigerant coils. Units are shipped standard with copper tube/aluminum fin construction. See model number nomenclature for coil options.

## Field-installed accessories

<b>Economizer with Solid-State Controls and Barometric Relief Dampers</b>
<b>Manual Air Damper (25% open)</b>
<b>Filter Rack</b>
<b>Flat Roof Curbs (8-in. and 14-in.)</b>
<b>Square-to-Round Duct Transition Kit</b>
<b>Thermostats</b>
<b>Controls Upgrade Kit</b>
<b>Crankcase Heater</b>
<b>Compressor Hard Start Kit (for use on single-phase units only)</b>
<b>LP Conversion Kit</b>
<b>High Altitude Kit</b>
<b>Rigging Kit</b>
<b>Low Ambient Kit (Motormaster® II Control)</b>
<b>Solid-State Time Guard® II Device</b>

**Economizer with solid-state controls and barometric relief dampers** includes filter racks and provide outdoor air during cooling and reduce compressor operation.

**Manual outside air damper** includes hood and filter rack with adjustable damper blade for up to 25% outdoor air.

**Flat roof curbs** in both 8 in. and 14 in. sizes are available for roof mounted applications.

**Square-to-round duct transition kit** enables 024-048 size units to be fitted to 14 in. round ductwork.

**Compressor hard start kit** assists compressor start-up by providing additional starting torque on single phase units and prolongs compressor motor life.

**Corporate Thermostats** provide control for the system heating and cooling functions. Thermostat models are available in both programmable and non-programmable versions.

**Controls upgrade kit** supplies high and low pressure safety protection and protects the unit from operating in unsuitable conditions.

**Crankcase heater** provides anti-floodback protection for low-load cooling applications.

**LP (liquid propane) conversion kit** allows for conversion from natural gas to liquid propane fuel.

**Rigging kit** includes lifting brackets which are inserted into the unit base rigging holds to lift unit for rooftop applications.

**Low-ambient kit (Motormaster II control)** allows the use of mechanical cooling down to outdoor temperatures as low as 0°F.

**Solid-state Time Guard II device** provides short-cycling protection for the compressor. Not required with corporate electronic thermostats.

**Filter rack** features easy installation, serviceability, and high-filtering performance for vertical applications.

**High altitude kit** is for use at 2001 to 6000 ft above sea level. Kit consists of natural gas orifices that compensate for gas heat operation at high altitude.

574A

574A

### ECONOMIZER

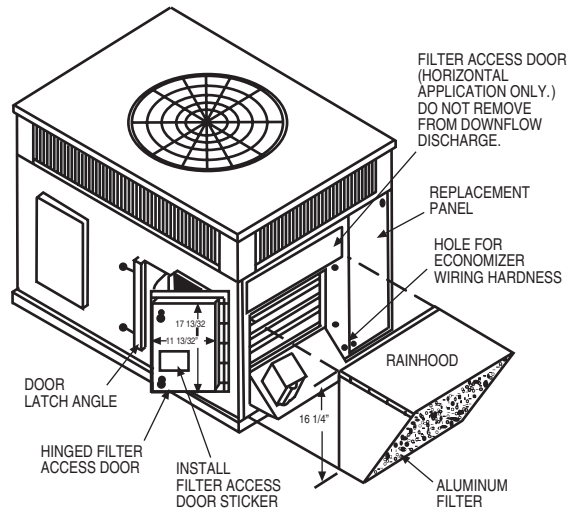
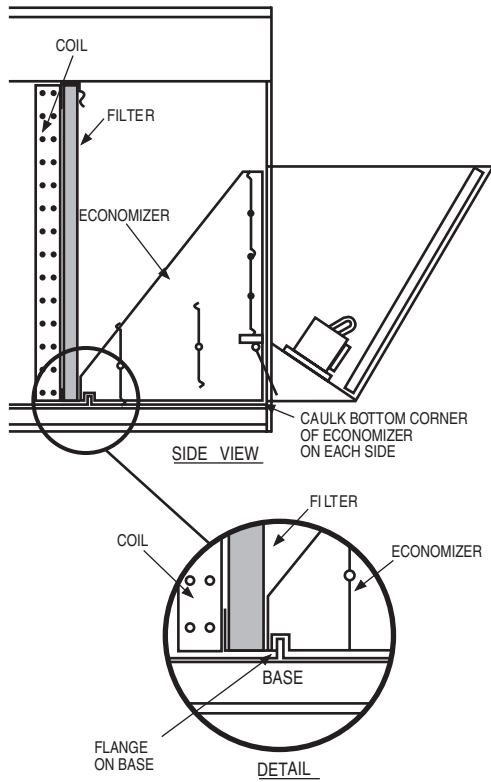

### FILTER RACK

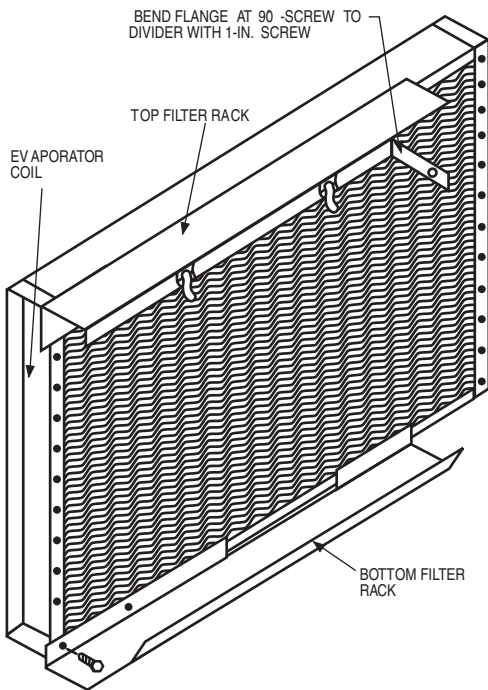

### MANUAL OUTSIDE AIR DAMPER

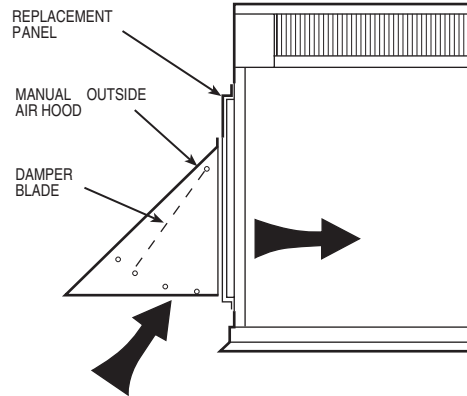

# BASE UNIT DIMENSIONS—574A024—030

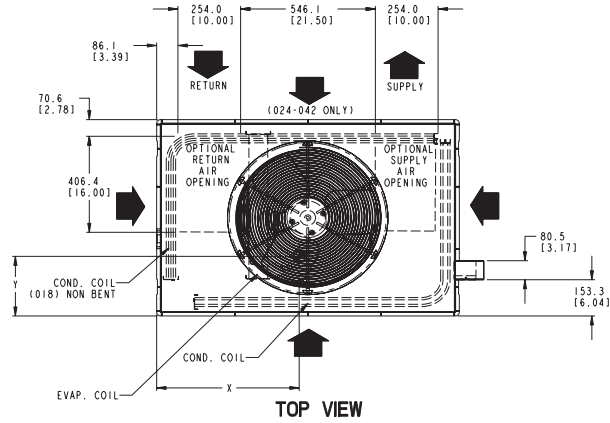
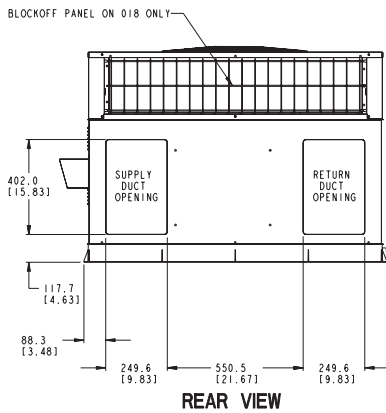

**REQUIRED CLEARANCE TO COMBUSTIBLE MATL**  
(Refer to Maximum Operating Clearances)

	INCHES	[mm]
TOP OF UNIT	14.00	[355.6]
DUCT SIDE OF UNIT	2.00	[50.8]
SIDE OPPOSITE DUCTS	14.00	[355.6]
BOTTOM OF UNIT	0.50	[12.7]

**NEC. REQUIRED CLEARANCES.**

	INCHES	[mm]
BETWEEN UNITS, POWER ENTRY SIDE	42.00	[1066.8]
UNIT AND UNGROUNDED SURFACES, POWER ENTRY SIDE	36.00	[914.0]
UNIT AND BLOCK OR CONCRETE WALLS AND OTHER GROUNDED SURFACES, POWER ENTRY SIDE	42.00	[1066.8]

**LEGEND**

- CG - Center of Gravity
- COND - Condensor
- EVAP - Evaporator
- NEC - National Electrical Code
- REQ'D - Required

NOTE: Dimensions are in in. [mm]

**REQUIRED CLEARANCE FOR OPERATION AND SERVICING**

	INCHES	[mm]
EVAP. COIL ACCESS SIDE	36.00	[914.0]
POWER ENTRY SIDE	42.00	[1066.8]
(EXCEPT FOR NEC REQUIREMENTS)		
UNIT TOP	48.00	[1219.2]
SIDE OPPOSITE DUCTS	36.00	[914.0]
DUCT PANEL	12.00	[304.8]

\*MINIMUM DISTANCES: IF UNIT IS PLACED LESS THAN 12.00 [304.8] FROM WALL SYSTEM, THEN SYSTEM PERFORMANCE MAYBE COMPROMISE.

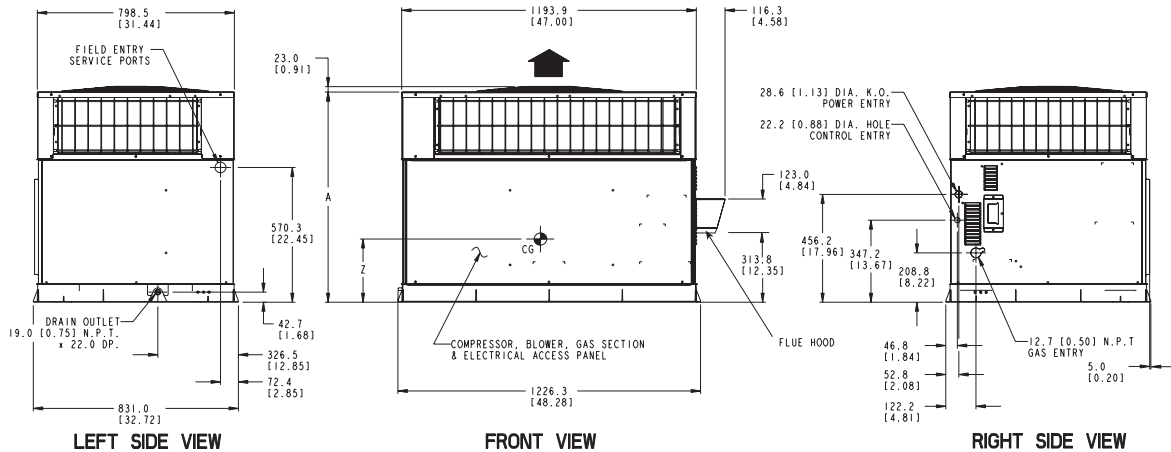

UNIT	ELECTRICAL CHARACTERISTICS	UNIT WEIGHT		UNIT HEIGHT in. [mm] "A"	CENTER OF GRAVITY in. [mm]		
		lb	kg		X	Y	Z
574A024040/060	208/230-1-60	343.0	156.0	39.02 [991.0]	20.0 [508.0]	19.3 [490.0]	17.6 [447.0]
574A030040/060	208/230-1-60	366.0	166.0	41.02 [1042.0]	20.0 [508.0]	14.0 [356.0]	13.0 [330.0]

574A

# BASE UNIT DIMENSIONS—574A036—060

574A

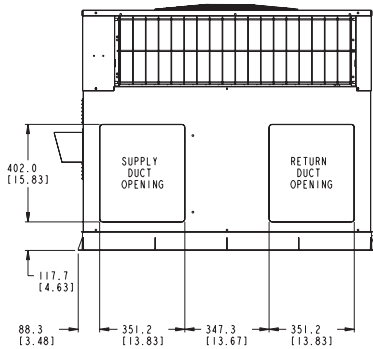

**REAR VIEW**

**REQUIRED CLEARANCE TO COMBUSTIBLE MATL  
(Refer to Maximum Operating Clearances)**

	INCHES	[mm]
TOP OF UNIT	14.00	[355.6]
DUCT SIDE OF UNIT	2.00	[50.8]
SIDE OPPOSITE DUCTS	14.00	[355.6]
BOTTOM OF UNIT	0.50	[12.7]

**NEC. REQUIRED CLEARANCES.**

	INCHES	[mm]
BETWEEN UNITS, POWER ENTRY SIDE	42.00	[1066.8]
UNIT AND UNGROUNDED SURFACES, POWER ENTRY SIDE	36.00	[914.0]
UNIT AND BLOCK OR CONCRETE WALLS AND OTHER GROUNDED SURFACES, POWER ENTRY SIDE	42.00	[1066.8]

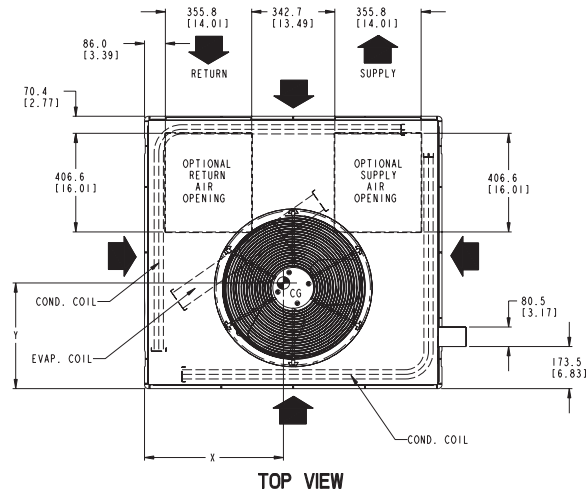

**TOP VIEW**

**REQUIRED CLEARANCE FOR OPERATION AND SERVICING**

	INCHES	[mm]
EVAP. COIL ACCESS SIDE	36.00	[914.0]
POWER ENTRY SIDE	42.00	[1066.8]
(EXCEPT FOR NEC REQUIREMENTS)		
UNIT TOP	48.00	[1219.2]
SIDE OPPOSITE DUCTS	36.00	[914.0]
DUCT PANEL	12.00	[304.8]

\*MINIMUM DISTANCES: IF UNIT IS PLACED LESS THAN 12.00 [304.8] FROM WALL SYSTEM, THEN SYSTEM PERFORMANCE MAYBE COMPROMISE.

**LEGEND**

- CG - Center of Gravity
- COND - Condensor
- EVAP - Evaporator
- NEC - National Electrical Code
- REQ'D - Required

NOTE: Dimensions are in in. [mm]

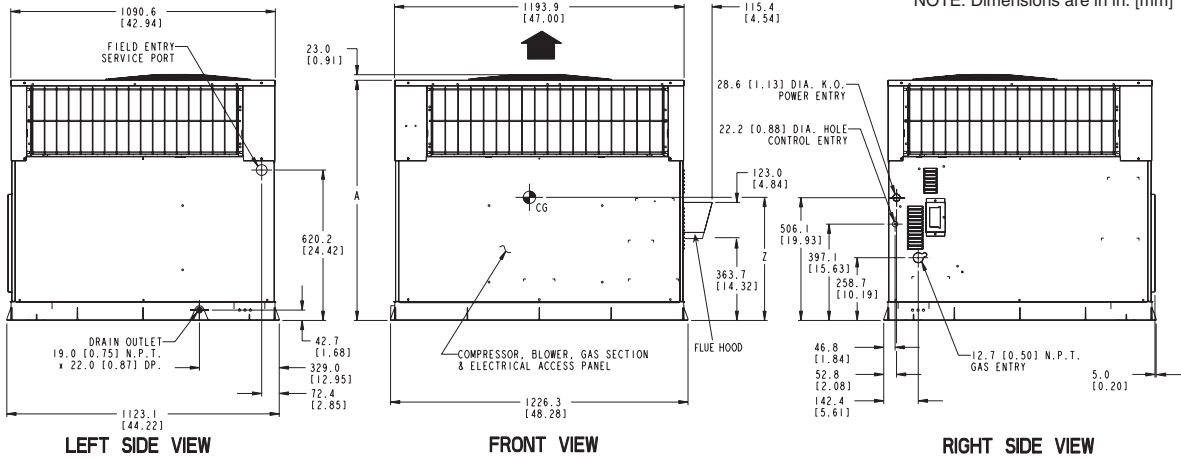

**LEFT SIDE VIEW**

**FRONT VIEW**

**RIGHT SIDE VIEW**

UNIT	ELECTRICAL CHARACTERISTICS	UNIT WEIGHT		UNIT HEIGHT in. [mm] "A"	CENTER OF GRAVITY in. [mm]		
		lb	kg		X	Y	Z
574A036060/090	208/230-1-60	433.0	196.0	42.98 [1092.0]	21.0 [533.0]	20.5 [520.0]	16.6 [422.0]
574A042060/090	208/230-1-60	460.0	209.0	46.98 [1193.0]	21.0 [533.0]	20.5 [520.0]	17.1 [434.0]
574A048090/115/130	208/230-1-60	480.0	218.0	46.98 [1193.0]	21.0 [533.0]	20.5 [520.0]	17.4 [442.0]
574A060090/115/130	208/230-1-60	492.0	223.0	46.98 [1193.0]	21.0 [533.0]	20.5 [520.0]	17.6 [447.0]



# ACCESSORY DIMENSIONS

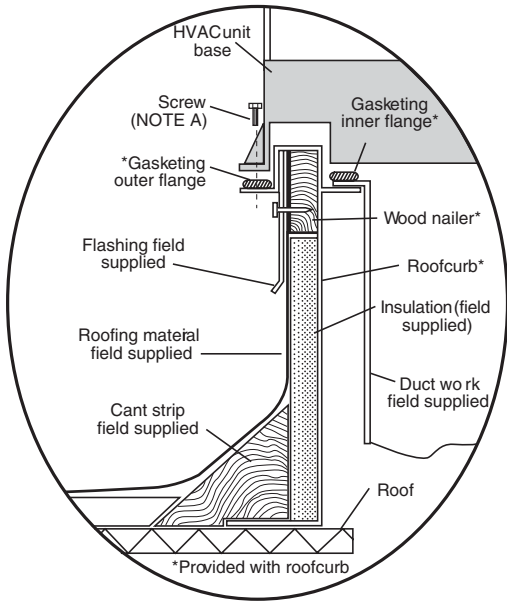

**Roof Curb for Small Cabinet**

Note A: When unit mounting screw is used retainer bracket must also be used.

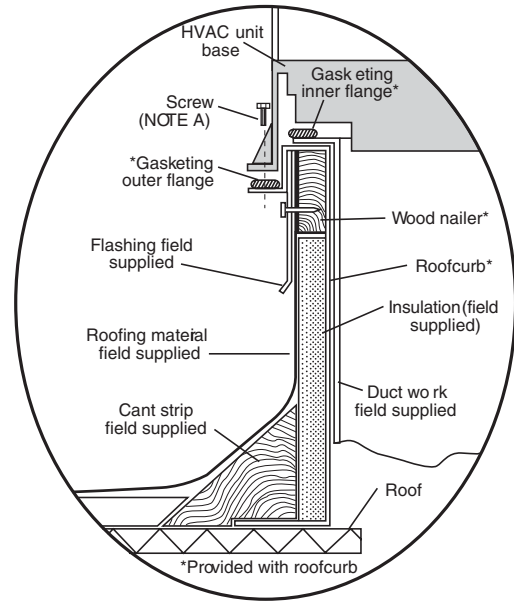

**Roof Curb for Large Cabinet**

Note A: When unit mounting screw is used retainer bracket must also be used.

574A

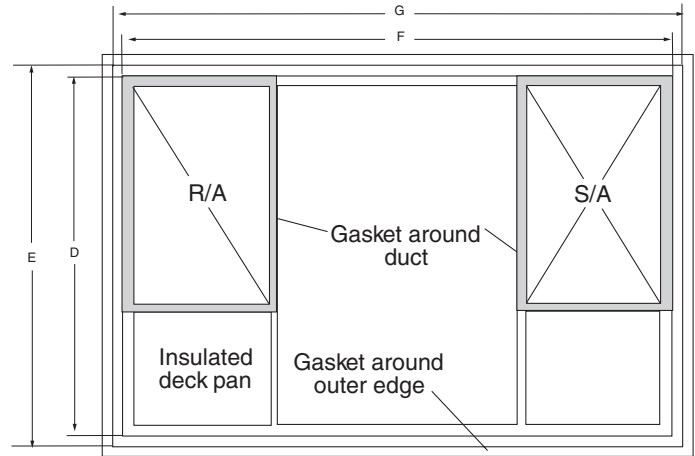
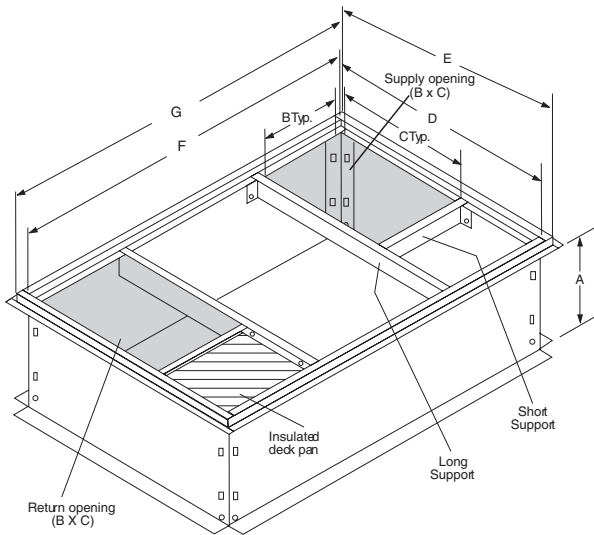

UNIT SIZE	ODS ORDER NUMBER	A IN. [MM]	B IN. [MM]	C IN. [MM]	D IN. [MM]	E IN. [MM]	F IN. [MM]	G IN. [MM]
024-030	CPRFCURB006A00	8 [203]	11 [279]	16-1/2 [419]	28-3/4 [730]	30-3/8 [771]	44-5/16 [1126]	45-15/16 [1167]
	CPRFCURB007A00	14 [356]	11 [279]	16-1/2 [419]	28-3/4 [730]	30-3/8 [771]	44-5/16 [1126]	45-15/16 [1167]
036-060	CPRFCURB008A00	8 [203]	16-3/16 [411]	17-3/8 [441]	40-1/4 [1022]	41-15/16 [1065]	44-7/16 [1129]	46-1/16 [1169]
	CPRFCURB009A00	14 [356]	16-3/16 [411]	17-3/8 [441]	40-1/4 [1022]	41-15/16 [1065]	44-7/16 [1129]	46-1/16 [1169]

**Notes:**

- Roof curb must be set up for unit being installed.
- Seal strip must be applied as required to unit being installed.
- Dimensions in [ ] are in millimeters.
- Roof curb is made of 16 gage steel.
- Table lists only the dimensions per part number that have changed.
- Attach ductwork to curb (flanges of duct rest on curb).
- Insulated panels: 1-in. thick fiberglass 1 lb. density.
- Dimensions are in inches.
- When unit mounting screw is used (see Note A), a retainer bracket must be used as well. This bracket must also be used when required by code for hurricane or seismic conditions. This bracket is available through Micrometl.

# 574A CORNER WEIGHTS

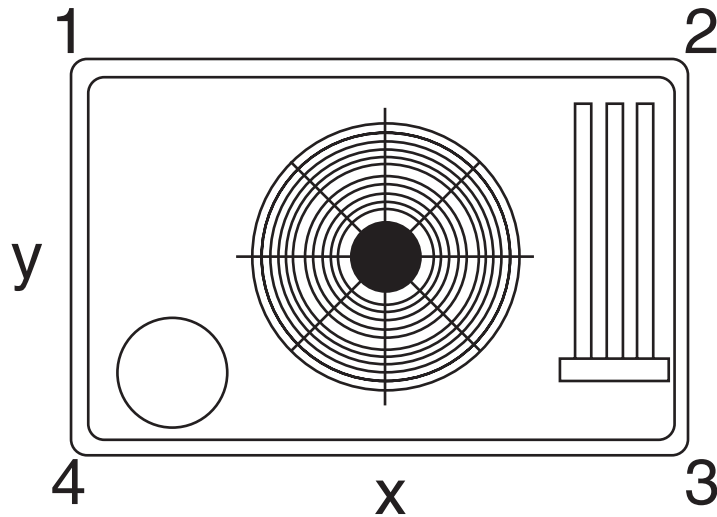

574A

CORNER WEIGHTS (SMALL CABINET)				CORNER WEIGHTS (LARGE CABINET)					
Model 574A	Unit	024	030	Model 574A	Unit	036	042	048	060
	Total Weight	343	366		Total Weight	433	460	480	492
	Corner Weight 1	69	74		Corner Weight 1	87	93	97	99
	Corner Weight 2	53	57		Corner Weight 2	68	72	74	76
	Corner Weight 3	83	88		Corner Weight 3	104	111	116	119
Corner Weight 4	138	147	Corner Weight 4	174	184	193	198		

## SELECTION PROCEDURE (WITH EXAMPLE)

### 1. Determine cooling and heating requirements at design conditions:

Given:

Required Cooling Capacity (TC).....34,000 Btuh  
 Sensible Heat Capacity (SHC).....25,000 Btuh  
 Required Heating Capacity.....60,000 Btuh  
 Condenser Entering Air Temperature.....95°F  
 Indoor–Air Temperature.....80°F edb 67°F ewb  
 Evaporator Air Quantity.....1200 CFM  
 External Static Pressure.....0.1 in. wg  
 Electrical Characteristics.....208–1–60

### 2. Select unit based on required cooling capacity.

Enter Net Cooling Capacities table at outdoor entering temperature of 95°F. Unit 574A036 at 1200 cfm and 67°F ewb (entering wet bulb) will provide a total capacity of 36,000 Btuh and a SHC of 27,400 Btuh. Calculate SHC correction, if required, using Note 4 under Cooling Capacities tables.

### 3. Select heating capacity of unit to provide design condition requirement.

In the Heating Capacities and Efficiencies table on page 4, note that the unit 574A036090 will provide 70,000 Btuh with an input of 88,000 Btuh.

### 4. Determine fan speed and power requirements at design conditions.

Before entering the air delivery tables, calculate the total static pressure required. From the given example, the Wet Coil Pressure Drop Table, and the Filter Pressure Drop table on page 16, find at 1200 cfm:

External Static Pressure	0.10 in. wg
Wet Coil	0.059 in. wg
Filter	<u>0.13 in. wg</u>
Total Static Pressure	0.29 in. wg

Enter the table for Dry Coil Air Delivery—horizontal and down-flow Discharge on page 15. For 208 v operation, deduct 10% from the value given. At 0.33 ESP (external static pressure), the fan will deliver about 1404 cfm at medium speed. The fan speed should be set at medium speed.

### 5. Select unit that corresponds to power source available.

The Electrical Data table on page 20 shows that the unit is designed to operate at 208–1–60.

# PERFORMANCE DATA

574A 024 Cooling Performance Table

Temp (F) Outdoor Air Entering Condenser		Evaporator Air - CFM/BF														
		700 / .08					800 / 0.10					900 / 0.11				
		Evaporator Air Ewb (F)														
		57	62	63*	67	72	57	62	63*	67	72	57	62	63*	67	72
75	TC	21.0	23.2	23.6	25.6	29.0	22.0	23.9	24.2	26.1	28.0	22.9	24.5	24.7	26.5	28.3
	SHC	21.0	21.1	17.1	17.8	14.7	22.0	22.8	18.3	19.1	14.7	22.9	24.3	19.5	20.2	15.3
	kW	1.7	1.7	1.7	1.7	1.7	1.8	1.8	1.8	1.8	1.8	1.8	1.9	1.9	1.9	1.9
85	TC	20.2	22.2	22.6	24.5	27.1	21.2	22.9	23.1	25.2	27.6	22.1	23.6	23.6	25.6	27.9
	SHC	20.2	20.7	16.6	17.4	13.9	21.2	22.3	17.9	18.7	14.7	22.1	23.4	19.0	20.0	15.4
	kW	1.9	1.9	1.9	1.9	1.9	1.9	2.0	2.0	2.0	2.0	2.0	2.0	2.0	2.1	2.1
95	TC	19.5	21.2	21.5	23.4	26.1	20.4	21.9	22.1	24.0	26.7	21.2	22.7	22.5	24.4	27.1
	SHC	19.5	20.2	16.2	16.9	13.6	20.4	21.7	17.4	18.2	14.4	21.2	22.5	18.5	19.5	15.2
	kW	2.1	2.1	2.1	2.1	2.1	2.2	2.2	2.2	2.2	2.2	2.2	2.3	2.3	2.3	2.3
105	TC	18.7	20.1	20.4	22.3	24.9	19.6	21.0	20.9	22.8	25.5	20.4	21.8	21.3	23.2	25.9
	SHC	18.7	19.6	15.7	16.4	13.1	19.6	20.8	16.9	17.7	14.0	20.4	21.6	18.0	19.0	14.8
	kW	2.3	2.3	2.3	2.3	2.4	2.4	2.4	2.4	2.4	2.4	2.5	2.5	2.5	2.5	2.5
115	TC	17.8	19.0	19.2	21.0	23.6	18.6	20.0	19.7	21.5	24.1	19.4	20.8	20.1	21.9	24.5
	SHC	17.8	18.9	15.1	15.9	12.7	18.6	19.8	16.3	17.2	13.5	19.4	20.6	17.5	18.5	14.3
	kW	2.5	2.5	2.5	2.6	2.6	2.6	2.6	2.6	2.7	2.7	2.7	2.7	2.7	2.7	2.8
125	TC	16.8	18.0	17.9	19.7	22.2	17.6	18.9	18.3	20.1	22.6	18.3	19.6	18.7	20.5	23.0
	SHC	16.8	17.8	14.6	15.4	12.1	17.6	18.7	15.8	16.7	13.0	18.3	19.4	16.9	17.9	13.8
	kW	2.8	2.8	2.8	2.8	2.9	2.9	2.9	2.9	2.9	2.9	3.0	3.0	3.0	3.0	3.0

574A

574A 030 Cooling Performance Table

Temp (F) Outdoor Air Entering Condenser		Evaporator Air - CFM/BF														
		875 / 0.08					1000 / 0.09					1125 / 0.10				
		Evaporator Air Ewb (F)														
		57	62	63*	67	72	57	62	63*	67	72	57	62	63*	67	72
75	TC	26.3	29.1	29.6	32.1	33.9	27.6	29.9	30.4	32.7	34.2	28.6	30.7	31.0	33.1	34.3
	SHC	26.3	26.3	21.3	22.1	17.2	27.6	28.1	22.8	23.6	17.8	28.6	29.7	24.2	24.8	18.3
	kW	2.2	2.2	2.2	2.2	2.2	2.3	2.3	2.3	2.3	2.3	2.3	2.4	2.3	2.4	2.4
85	TC	25.4	27.7	28.3	30.7	33.2	26.6	28.6	29.0	31.5	33.6	27.6	29.5	29.6	32.1	33.9
	SHC	25.4	25.8	20.8	21.7	17.3	26.6	27.6	22.3	23.3	18.1	27.6	28.8	23.8	24.9	18.9
	kW	2.4	2.4	2.4	2.4	2.4	2.5	2.5	2.5	2.5	2.5	2.6	2.6	2.6	2.6	2.6
95	TC	24.4	26.4	26.8	29.3	32.7	25.5	27.3	27.5	30.0	32.9	26.5	28.1	28.0	30.6	33.4
	SHC	24.4	25.2	20.2	21.2	16.9	25.5	26.6	21.7	22.8	17.9	26.5	27.9	23.2	24.3	18.8
	kW	2.6	2.6	2.6	2.7	2.7	2.7	2.7	2.7	2.7	2.7	2.8	2.8	2.8	2.8	2.8
105	TC	23.4	25.0	25.4	27.7	31.1	24.5	25.9	26.0	28.3	31.8	25.4	26.9	26.4	28.9	32.3
	SHC	23.4	24.4	19.6	20.6	16.3	24.5	25.8	21.1	22.2	17.3	25.4	26.7	22.5	23.7	18.3
	kW	2.9	2.9	2.9	2.9	2.9	2.9	3.0	3.0	3.0	3.0	3.0	3.0	3.0	3.1	3.1
115	TC	22.3	23.7	23.8	26.1	29.3	23.4	24.7	24.4	26.7	30.0	24.2	25.7	24.8	27.1	30.5
	SHC	22.3	23.4	19.0	20.0	15.7	23.4	24.6	20.5	21.6	16.7	24.2	25.5	21.9	23.1	17.7
	kW	3.1	3.1	3.1	3.2	3.2	3.2	3.2	3.2	3.3	3.3	3.3	3.3	3.3	3.4	3.4
125	TC	21.1	22.3	22.1	24.4	27.6	22.1	23.4	22.6	24.9	28.1	23.0	24.3	23.1	25.4	28.6
	SHC	21.1	22.2	18.3	19.4	15.1	22.1	23.3	19.8	20.9	16.1	23.0	24.2	21.1	22.4	17.1
	kW	3.4	3.4	3.4	3.5	3.5	3.5	3.5	3.5	3.6	3.6	3.6	3.6	3.6	3.7	3.7

See Legend and Notes on page 13.

# PERFORMANCE DATA CONTINUED

574A 036 Cooling Performance Table

Temp (F) Outdoor Air Entering Condenser		Evaporator Air - CFM/BF														
		1050 / 0.07					1200 / 0.08					1350 / 0.10				
		Evaporator Air Ewb (F)														
		57	62	63*	67	72	57	62	63*	67	72	57	62	63*	67	72
75	TC	32.8	35.1	35.8	38.8	40.9	34.5	36.2	36.8	39.6	41.5	35.9	37.3	37.5	40.0	41.8
	SHC	32.8	31.9	25.8	26.9	22.5	34.5	27.7	28.7	21.6	35.9	36.7	29.5	30.2	22.3	
	kW	2.6	2.6	2.6	2.7	2.6	2.7	2.7	2.7	2.8	2.8	2.8	2.8	2.8	2.8	2.8
85	TC	31.4	33.3	34.0	37.1	40.5	33.0	34.4	34.9	38.1	40.9	34.4	35.7	35.6	38.9	41.4
	SHC	31.4	31.0	24.9	26.2	21.0	33.0	33.5	26.8	28.2	22.0	34.4	35.1	28.6	30.1	22.9
	kW	2.9	2.9	2.9	2.9	2.9	3.0	3.0	3.0	3.0	3.0	3.1	3.1	3.1	3.1	3.1
95	TC	30.0	31.5	32.1	35.1	39.4	31.5	32.7	32.9	36.0	40.3	32.8	34.0	33.5	36.7	40.9
	SHC	30.0	30.1	24.1	25.3	20.4	31.5	32.2	25.9	27.4	21.7	32.8	33.5	27.7	29.3	22.8
	kW	3.1	3.2	3.2	3.2	3.2	3.2	3.2	3.2	3.3	3.3	3.3	3.3	3.3	3.4	3.4
105	TC	28.5	29.6	30.1	33.0	37.2	30.0	31.1	30.8	33.8	38.1	31.2	32.3	31.4	34.4	38.8
	SHC	28.5	29.1	23.2	24.5	19.6	30.0	30.6	25.1	26.5	20.9	31.2	31.8	26.8	28.3	22.1
	kW	3.4	3.5	3.5	3.5	3.5	3.5	3.5	3.5	3.6	3.6	3.6	3.6	3.6	3.7	3.7
115	TC	27.9	29.3	29.4	32.4	34.8	28.3	29.4	28.7	31.5	35.6	29.5	30.5	29.3	32.1	36.3
	SHC	27.9	30.5	24.1	25.5	18.7	28.3	28.9	24.2	25.6	20.0	29.5	30.1	25.9	27.4	21.2
	kW	3.8	3.8	3.8	3.9	3.9	3.9	3.9	3.9	3.9	3.9	4.0	4.0	3.9	4.0	4.0
125	TC	26.5	29.1	28.7	31.8	32.4	26.7	27.4	29.0	30.7	33.1	27.0	28.7	29.2	29.8	33.7
	SHC	28.1	28.6	23.0	24.4	17.8	29.5	26.9	26.8	26.6	19.1	27.7	28.2	28.7	26.5	20.3
	kW	4.2	4.2	4.2	4.2	4.2	4.3	4.2	4.3	4.3	4.3	4.3	4.3	4.3	4.3	4.4

574A

574A 042 Cooling Performance Table

Temp (F) Outdoor Air Entering Condenser		Evaporator Air - CFM/BF														
		1225 / 0.11					1400 / 0.12					1575 / 0.14				
		Evaporator Air Ewb (F)														
		57	62	63*	67	72	57	62	63*	67	72	57	62	63*	67	72
75	TC	36.8	40.2	41.7	42.5	45.4	38.2	41.8	41.1	45.3	45.5	39.3	40.7	41.1	44.4	46.3
	SHC	36.8	38.5	28.5	28.5	21.8	38.2	40.0	29.8	31.5	23.0	39.3	37.4	31.0	32.2	24.1
	kW	3.1	3.3	3.3	3.2	3.6	3.2	3.3	3.3	3.3	3.3	3.3	3.4	3.5	3.4	3.4
85	TC	35.4	38.1	40.0	41.6	44.3	36.8	38.9	40.5	42.1	44.8	38.0	40.2	40.9	43.8	45.2
	SHC	35.4	36.4	27.7	28.2	22.0	36.8	38.3	29.6	30.2	23.4	38.0	39.5	31.6	32.8	24.9
	kW	3.5	3.4	3.4	3.4	3.6	3.6	3.5	3.5	3.6	3.5	3.7	3.6	3.6	3.6	3.6
95	TC	34.1	37.2	38.0	40.8	43.8	35.4	38.6	38.8	41.5	44.0	36.5	39.6	37.9	42.0	44.4
	SHC	34.1	35.5	26.9	27.9	21.9	35.4	36.9	28.9	30.0	23.0	36.5	37.8	30.0	32.1	24.2
	kW	3.9	3.7	3.7	3.7	3.7	4.0	3.8	3.8	3.8	3.8	4.1	3.8	3.8	3.9	3.9
105	TC	32.4	35.1	35.6	38.2	40.7	33.7	36.5	36.2	38.8	41.2	34.7	35.4	34.7	37.4	41.4
	SHC	32.4	33.6	25.8	26.9	20.8	33.7	34.9	27.8	29.0	21.8	34.7	33.8	28.5	29.8	22.3
	kW	4.0	4.0	4.0	4.0	4.0	4.1	4.0	4.0	4.1	4.1	4.2	4.1	4.1	4.1	4.2
115	TC	30.1	33.4	33.5	36.1	37.3	31.3	32.9	32.4	35.0	39.0	32.3	33.9	31.6	34.0	38.0
	SHC	30.1	31.9	25.0	26.0	18.9	31.3	31.5	26.2	27.3	21.3	32.3	32.4	30.2	32.5	22.1
	kW	4.4	4.3	4.3	4.4	4.3	4.5	4.7	4.4	4.4	4.5	4.6	4.8	4.8	4.8	4.9
125	TC	27.9	29.6	28.4	32.4	34.2	32.2	29.9	28.6	31.2	34.1	29.7	30.8	29.0	31.7	34.1
	SHC	27.9	28.3	24.3	24.7	19.2	18.9	28.6	24.5	25.7	19.1	29.7	29.4	26.7	27.5	17.8
	kW	4.8	4.9	4.9	4.8	5.1	5.0	4.7	4.7	4.8	5.1	5.2	4.9	4.8	4.8	4.9

See Legend and Notes on page 13.

# PERFORMANCE DATA CONTINUED

574A 048 Cooling Performance Table

Temp (F) Outdoor Air Entering Condenser		Evaporator Air - CFM/BF														
		1400 / 0.07					1600 / 0.08					1800 / 0.09				
		Evaporator Air Ewb (F)														
		57	62	63*	67	72	57	62	63*	67	72	57	62	63*	67	72
75	TC	42.5	45.5	46.3	50.1	53.6	44.4	46.9	47.4	51.1	54.2	46.1	48.2	48.3	51.8	54.6
	SHC	42.5	41.7	33.5	34.7	26.6	44.4	44.8	35.8	37.0	27.7	46.1	47.3	38.1	39.1	28.7
	kW	3.4	3.5	3.5	3.5	3.5	3.5	3.5	3.5	3.5	3.6	3.6	3.6	3.6	3.6	3.7
85	TC	41.0	43.6	44.2	48.1	52.6	42.9	45.0	45.3	49.2	53.4	44.5	46.5	46.2	50.1	53.9
	SHC	41.0	40.7	32.5	34.1	26.4	42.9	43.6	34.9	36.5	27.7	44.5	45.6	37.1	38.9	28.9
	kW	3.8	3.8	3.8	3.8	3.8	3.8	3.9	3.9	3.9	3.9	3.9	4.0	4.0	4.0	4.0
95	TC	39.4	41.6	42.2	45.9	50.8	41.2	43.0	43.1	47.0	51.7	42.8	44.6	44.6	47.8	52.4
	SHC	39.4	39.7	31.6	33.1	25.9	41.2	42.2	34.0	35.7	27.4	42.8	43.8	37.7	38.1	28.7
	kW	4.1	4.1	4.2	4.2	4.2	4.2	4.2	4.2	4.3	4.3	4.3	4.3	5.6	4.4	4.4
105	TC	37.7	39.5	39.9	43.6	48.5	39.3	41.3	40.9	44.5	49.5	40.9	42.7	41.6	45.3	50.2
	SHC	37.7	38.5	30.7	32.2	25.1	39.3	40.5	33.0	34.7	26.7	40.9	41.9	35.2	37.1	28.1
	kW	4.5	4.5	4.5	4.6	4.6	4.5	4.6	4.6	4.7	4.7	4.7	4.7	4.7	4.8	4.8
115	TC	35.9	37.5	37.5	41.2	45.8	37.5	39.2	38.4	42.1	47.0	39.1	40.8	39.1	42.8	47.7
	SHC	35.9	36.8	29.7	31.3	24.1	37.5	38.4	31.9	33.7	25.9	39.1	40.0	34.1	36.1	27.4
	kW	4.9	4.9	4.9	5.0	5.1	5.0	5.0	5.0	5.1	5.1	5.1	5.1	5.1	5.2	5.2
125	TC	34.0	35.5	35.0	38.4	43.2	35.6	37.1	35.8	39.2	44.2	36.8	38.5	36.5	39.9	44.9
	SHC	34.0	34.9	28.6	30.2	23.2	35.6	36.4	30.9	32.6	24.9	36.8	37.7	33.0	34.9	26.5
	kW	5.4	5.4	5.4	5.4	5.5	5.5	5.5	5.5	5.5	5.6	5.6	5.6	5.6	5.6	5.7

574A

574A 060 Cooling Performance Table

Temp (F) Outdoor Air Entering Condenser		Evaporator Air - CFM/BF														
		1750 / 0.07					2000 / 0.08					2250 / 0.09				
		Evaporator Air Ewb (F)														
		57	62	63*	67	72	57	62	63*	67	72	57	62	63*	67	72
75	TC	51.1	55.3	56.1	60.7	66.2	53.5	57.0	57.4	62.0	67.0	55.4	58.7	58.5	62.9	67.7
	SHC	51.1	50.3	40.5	42.2	33.4	53.5	54.2	43.4	45.2	35.0	55.4	56.7	46.2	48.1	36.6
	kW	4.1	4.2	4.2	4.2	4.3	4.2	4.3	4.3	4.3	4.3	4.3	4.3	4.3	4.4	4.4
85	TC	49.4	53.1	53.9	58.3	64.0	51.7	54.8	55.2	59.6	65.1	53.6	56.8	56.1	60.6	65.8
	SHC	49.4	49.3	39.5	41.2	32.6	51.7	52.9	42.4	44.3	34.5	53.6	54.8	45.2	47.2	36.2
	kW	4.5	4.6	4.6	4.6	4.7	4.6	4.7	4.7	4.7	4.8	4.7	4.8	4.8	4.8	4.9
95	TC	47.5	50.8	51.4	55.8	61.5	49.8	52.7	52.6	57.0	62.5	51.6	54.7	53.6	58.0	63.3
	SHC	47.5	48.0	38.4	40.2	31.8	49.8	50.9	41.4	43.3	33.6	51.6	52.8	44.1	46.3	35.4
	kW	5.0	5.1	5.1	5.1	5.2	5.1	5.1	5.1	5.2	5.2	5.2	5.2	5.2	5.3	5.3
105	TC	45.5	48.2	48.6	53.0	58.8	47.6	50.5	49.8	54.2	59.8	49.4	52.4	50.7	55.1	60.6
	SHC	45.5	46.6	37.2	39.1	30.8	47.6	48.7	40.2	42.3	32.7	49.4	50.6	43.0	45.2	34.5
	kW	5.5	5.6	5.6	5.6	5.7	5.6	5.7	5.6	5.7	5.7	5.7	5.8	5.7	5.8	5.8
115	TC	43.2	45.8	45.5	49.9	55.8	45.3	48.0	46.6	51.0	56.8	47.0	49.8	47.6	52.0	57.6
	SHC	43.2	44.2	35.9	37.9	29.8	45.3	46.3	38.8	41.1	31.8	47.0	48.1	41.6	44.0	33.6
	kW	6.1	6.1	6.1	6.2	6.2	6.1	6.2	6.2	6.2	6.3	6.2	6.3	6.3	6.3	6.4
125	TC	40.7	43.1	42.1	46.5	52.5	42.7	45.2	43.2	47.6	53.5	44.4	47.0	44.1	48.5	54.2
	SHC	40.7	41.7	34.5	36.6	28.7	42.7	43.7	37.4	39.7	30.7	44.4	45.4	40.1	42.6	32.5
	kW	6.6	6.7	6.7	6.7	6.8	6.7	6.8	6.7	6.8	6.9	6.8	6.9	6.9	6.9	7.0

\* At 75°F entering dry bulb – Tennessee Valley Authority [TVA] rating conditions; all others at 80°F entering dry bulb.

**LEGEND**

BF — Bypass Factor  
 Ewb — Entering Wet-Bulb  
 kW — Total Unit Power Input  
 SHC — Sensible Heat Capacity (1000 Btuh)  
 TC — Total Capacity (1000 Btuh) (net)

**NOTES:**

1. Ratings are net; they account for the effects of the evaporator-fan motor power and heat.
2. Direct interpolation is permissible. Do not extrapolate.
3. The following formulas may be used:

$$t_{lwb} = t_{ewb} - \frac{\text{total capacity (Btuh)}}{4.5 \times \text{cfm}}$$

Where:  $t_{ewb}$  = Enthalpy of air entering evaporator coil

4. The SHC is based on 80° F edb temperature of air entering evaporator coil. Below 80° F edb, subtract (corr factor x cfm) from SHC. Above 80° F edb, add (corr factor x cfm) to SHC. Correction Factor =  $1.10 \times (1 + BF) \times (edb + 80)$ .

$$t_{ldb} = t_{edb} - \frac{\text{Sensible capacity (Btuh)}}{1.10 \times \text{cfm}}$$

$$t_{lwb} = \text{Wet-bulb temperature corresponding to enthalpy air leaving evaporator coil } (t_{lwb})$$

# PERFORMANCE DATA CONTINUED

Table 13 – Dry Coil Air Delivery\* – Horizontal and Downflow Discharge – Unit 574A024–060 (Deduct 10% for 208 Volts)

Unit	Heating Rise Range (°F)	Motor Speed		External Static Pressure (”WC)								
				0.1	0.2	0.3	0.4	0.5	0.6	0.7	0.8	0.9
574A(-,N)024040	20 – 50	Low <sup>1</sup>	Watts	311	309	304	301	286	---	---	---	---
			CFM	935	885	820	757	686	---	---	---	---
			Heating Rise (°F)	32	34	37	40	44	---	---	---	---
		Medium	Watts	---	---	---	---	379	357	357	345	---
			CFM	---	---	---	---	957	868	769	647	---
			Heating Rise (°F)	---	---	---	---	31	35	39	46	---
		High	Watts	---	---	---	---	---	---	447	435	421
			CFM	---	---	---	---	---	---	970	853	712
			Heating Rise (°F)	---	---	---	---	---	---	31	35	42
574A(-,N)024060	35 – 65	Low <sup>1</sup>	Watts	311	309	304	301	---	---	---	---	---
			CFM	935	885	820	757	---	---	---	---	---
			Heating Rise (°F)	48	51	55	59	---	---	---	---	---
		Medium	Watts	411	405	398	390	379	357	357	---	---
			CFM	1195	1155	1100	1028	957	868	769	---	---
			Heating Rise (°F)	38	39	41	44	47	52	59	---	---
		High	Watts	---	---	---	---	---	---	447	435	421
			CFM	---	---	---	---	---	---	970	853	712
			Heating Rise (°F)	---	---	---	---	---	---	46	53	63
574A(-,N)030040	20 – 50	Low	Watts	311	309	304	301	---	---	---	---	---
			CFM	935	885	820	757	---	---	---	---	---
			Heating Rise (°F)	32	34	37	40	---	---	---	---	---
		Medium <sup>1</sup>	Watts	411	405	398	390	379	357	357	---	---
			CFM	1195	1155	1100	1028	957	868	769	---	---
			Heating Rise (°F)	25	26	27	29	31	35	39	---	---
		High	Watts	---	---	---	---	477	467	447	435	---
			CFM	---	---	---	---	1185	1088	970	853	---
			Heating Rise (°F)	---	---	---	---	25	28	31	35	---
574A(-,N)030060	35 – 65	Low	Watts	311	309	304	301	---	---	---	---	---
			CFM	935	885	820	757	---	---	---	---	---
			Heating Rise (°F)	48	51	55	59	---	---	---	---	---
		Medium <sup>1</sup>	Watts	411	405	398	390	379	357	357	---	---
			CFM	1195	1155	1100	1028	957	868	769	---	---
			Heating Rise (°F)	38	39	41	44	47	52	59	---	---
		High	Watts	---	---	---	---	477	467	447	435	---
			CFM	---	---	---	---	1185	1088	970	853	---
			Heating Rise (°F)	---	---	---	---	38	41	46	53	---

574A

# PERFORMANCE DATA CONTINUED

Unit	Heating Rise Range (°F)	Motor Speed		External Static Pressure ("WC)								
				0.1	0.2	0.3	0.4	0.5	0.6	0.7	0.8	0.9
574A(-,N)036060	25 – 55	Low <sup>1</sup>	Watts	437	433	424	417	403	391	379	362	--
			CFM	1353	1318	1283	1235	1187	1123	1059	975	--
			Heating Rise (°F)	33	34	35	36	38	40	42	46	--
		Medium	Watts	--	--	--	531	516	496	478	459	435
			CFM	--	--	--	1489	1437	1362	1289	1208	1099
			Heating Rise (°F)	--	--	--	30	31	33	35	37	41
		High	Watts	--	--	--	--	--	--	--	629	602
			CFM	--	--	--	--	--	--	--	1470	1357
			Heating Rise (°F)	--	--	--	--	--	--	--	31	33
574A(-,N)036090	40 – 70	Low <sup>1</sup>	Watts	437	433	424	417	403	391	379	362	--
			CFM	1353	1318	1283	1235	1187	1123	1059	975	--
			Heating Rise (°F)	50	51	53	55	57	60	64	69	--
		Medium	Watts	--	--	--	531	516	496	478	459	435
			CFM	--	--	--	1489	1437	1362	1289	1208	1099
			Heating Rise (°F)	--	--	--	45	47	50	52	56	61
		High	Watts	--	--	--	--	--	--	--	629	602
			CFM	--	--	--	--	--	--	--	1470	1357
			Heating Rise (°F)	--	--	--	--	--	--	--	46	50
574A(-,N)042060	25 – 55	Low <sup>1</sup>	Watts	625	606	586	571	550	534	509	483	457
			CFM	1539	1496	1466	1437	1387	1330	1264	1183	1093
			Heating Rise (°F)	29	30	31	31	32	34	36	38	41
		Medium	Watts	--	741	715	694	669	645	610	573	544
			CFM	--	1738	1698	1653	1604	1538	1457	1362	1271
			Heating Rise (°F)	--	26	27	27	28	29	31	33	35
		High	Watts	--	--	--	--	--	798	772	738	700
			CFM	--	--	--	--	--	1720	1648	1540	1414
			Heating Rise (°F)	--	--	--	--	--	26	27	29	32
574A(-,N)042090	40 – 70	Low <sup>1</sup>	Watts	625	606	586	571	550	534	509	483	457
			CFM	1539	1496	1466	1437	1387	1330	1264	1183	1093
			Heating Rise (°F)	44	45	46	47	49	51	53	57	62
		Medium	Watts	--	--	715	694	669	645	610	573	544
			CFM	--	--	1698	1653	1604	1538	1457	1362	1271
			Heating Rise (°F)	--	--	40	41	42	44	46	50	53
		High	Watts	--	--	--	--	--	--	772	738	700
			CFM	--	--	--	--	--	--	1648	1540	1414
			Heating Rise (°F)	--	--	--	--	--	--	41	44	48

574A

# PERFORMANCE DATA CONTINUED

574A

Unit	Heating Rise Range (°F)	Motor Speed		External Static Pressure ("WC)								
				0.1	0.2	0.3	0.4	0.5	0.6	0.7	0.8	0.9
574A(-,N)048090	25 – 55	Low	Watts	627	617	607	584	567	548	528	503	---
			CFM	1550	1530	1493	1461	1414	1361	1320	1250	---
			Heating Rise (°F)	44	44	45	46	48	50	51	54	---
		Medium <sup>1</sup>	Watts	771	755	734	711	690	665	639	607	572
			CFM	1798	1771	1734	1687	1645	1595	1530	1449	1355
			Heating Rise (°F)	38	38	39	40	41	42	44	47	50
		High	Watts	---	---	908	887	858	827	804	767	748
			CFM	---	---	2000	1944	1876	1811	1735	1647	1555
			Heating Rise (°F)	---	---	34	35	36	37	39	41	43
574A(-,N)048115	35 – 65	Low	Watts	627	617	607	584	567	548	528	---	---
			CFM	1550	1530	1493	1461	1414	1361	1320	---	---
			Heating Rise (°F)	56	56	58	59	61	63	65	---	---
		Medium <sup>1</sup>	Watts	771	755	734	711	690	665	639	607	572
			CFM	1798	1771	1734	1687	1645	1595	1530	1449	1355
			Heating Rise (°F)	48	49	50	51	52	54	56	60	64
		High	Watts	---	---	908	887	858	827	804	767	748
			CFM	---	---	2000	1944	1876	1811	1735	1647	1555
			Heating Rise (°F)	---	---	43	44	46	48	50	52	55
574A(-,N)048130	40 – 70	Low	Watts	627	617	607	584	567	---	---	---	---
			CFM	1550	1530	1493	1461	1414	---	---	---	---
			Heating Rise (°F)	63	64	65	67	69	---	---	---	---
		Medium <sup>1</sup>	Watts	771	755	734	711	690	665	639	607	---
			CFM	1798	1771	1734	1687	1645	1595	1530	1449	---
			Heating Rise (°F)	54	55	56	58	59	61	64	67	---
		High	Watts	---	---	908	887	858	827	804	767	748
			CFM	---	---	2000	1944	1876	1811	1735	1647	1555
			Heating Rise (°F)	---	---	49	50	52	54	56	59	63
574A(-,N)060090	25 – 55	Low <sup>1</sup>	Watts	786	769	754	736	722	705	684	658	---
			CFM	2027	1960	1901	1821	1759	1693	1616	1513	---
			Heating Rise (°F)	33	34	36	37	38	40	42	45	---
		Medium	Watts	873	849	833	815	798	782	763	748	---
			CFM	2095	2026	1962	1887	1817	1748	1679	1583	---
			Heating Rise (°F)	32	33	34	36	37	39	40	43	---
		High	Watts	1012	993	981	963	948	927	904	886	---
			CFM	2184	2109	2036	1963	1886	1812	1729	1647	---
			Heating Rise (°F)	31	32	33	34	36	37	39	41	---



# PERFORMANCE DATA CONTINUED

Unit	Heating Rise Range (°F)	Motor Speed	External Static Pressure (”WC)									
			0.1	0.2	0.3	0.4	0.5	0.6	0.7	0.8	0.9	
574A(-,N)060115	35 – 65	Low <sup>1</sup>	Watts	786	769	754	736	722	705	684	658	---
			CFM	2027	1960	1901	1821	1759	1693	1616	1513	---
			Heating Rise (°F)	43	44	45	47	49	51	53	57	---
		Medium	Watts	873	849	833	815	798	782	763	748	---
			CFM	2095	2026	1962	1887	1817	1748	1679	1583	---
			Heating Rise (°F)	41	43	44	46	47	49	51	54	---
		High	Watts	1012	993	981	963	948	927	904	886	---
			CFM	2184	2109	2036	1963	1886	1812	1729	1647	---
			Heating Rise (°F)	39	41	42	44	46	48	50	52	---
574A(-,N)060130	40 – 70	Low <sup>1</sup>	Watts	786	769	754	736	722	705	684	658	---
			CFM	2027	1960	1901	1821	1759	1693	1616	1513	---
			Heating Rise (°F)	48	50	51	54	55	58	60	64	---
		Medium	Watts	873	849	833	815	798	782	763	748	---
			CFM	2095	2026	1962	1887	1817	1748	1679	1583	---
			Heating Rise (°F)	47	48	50	52	54	56	58	62	---
		High	Watts	1012	993	981	963	948	927	904	886	---
			CFM	2184	2109	2036	1963	1886	1812	1729	1647	---
			Heating Rise (°F)	45	46	48	50	52	54	56	59	---

574A

\*Air delivery values are without air filter and are for dry coil (See Table 15 - 574A Wet Coil Pressure Drop table).

<sup>1</sup>Factory-shipped heating/cooling speed

“NA” = Not allowed for heating speed

Note: Deduct field-supplied air filter pressure drop and wet coil pressure drop to obtain external static pressure available for ducting.

## FILTER PRESSURE DROP (in. wg)

FILTER SIZE	CFM																		
	500	600	700	800	900	1000	1100	1200	1300	1400	1500	1600	1700	1800	1900	2000	2100	2200	2300
20 X 24 X 1	0.04	0.06	0.07	0.08	0.09	0.1	0.11	0.13	0.14	0.15	0.16	—	—	—	—	—	—	—	—
24 X 36 X 1	—	—	—	—	—	—	—	0.07	0.08	0.09	0.1	0.11	0.12	0.13	0.14	0.15	0.16	0.17	0.18

## STANDARD CFM (S.C.F.M.)

UNIT SIZE	600	700	800	900	1000	1100	1200	1300	1400	1500	1600	1700	1800	1900	2000
024	0.030	0.037	0.044	0.053	0.063	-	-	-	-	-	-	-	-	-	-
030	-	0.037	0.044	0.053	0.063	0.072	0.081	0.105	-	-	-	-	-	-	-
036	-	-	-	0.038	0.044	0.051	0.059	0.065	0.072	0.080	-	-	-	-	-
042	-	-	-	-	0.044	0.051	0.059	0.065	0.072	0.080	0.088	0.095	0.105	-	-
048	-	-	-	-	-	-	0.044	0.050	0.053	0.059	0.066	0.072	0.077	0.086	-
060	-	-	-	-	-	-	-	-	-	0.079	0.087	0.095	0.102	0.113	0.123

## ECONOMIZER 1-in. FILTER PRESSURE DROP (in. wg)

Unit 574A	Pressure Drop
024-030	0.20
036-060	0.25

# PERFORMANCE DATA (CONT)

## HIGH ALTITUDE COMPENSATION

### NATURAL GAS ONLY

#### ORIFICE CONVERSION—3.5 IN. WG MANIFOLD PRESSURE\*

ALTITUDE (ft)	INPUT (Btuh)	OUTPUT (Btuh)	ORIFICE NUMBER†
0–2000	40,000	31,000	#44
	60,000	46,000	#38
	90,000	70,000	#38
	115,000	92,000	#33
	130,000	103,000	#31
2001–6000	32,075	24,858	#48
	48,547	37,219	#42
	72,820	56,638	#42
	90,094	72,075	#37
	102,630	81,315	#34

\*As the height above sea level increases, there is less oxygen per cubic ft of air. Therefore, heat input rate should be reduced at higher altitudes.

†Orifices available through your Bryant distributor.

### LIQUID PROPANE ONLY

#### ORIFICE CONVERSION—3.5 IN. WG MANIFOLD PRESSURE\*

ALTITUDE (ft)	INPUT (Btuh)	OUTPUT (Btuh)	ORIFICE NUMBER†
0–2000	40,000	31,000	#50
	57,000	43,720	#46
	85,500	66,520	#46
	115,000	92,000	#42
	127,000	100,580	#41
2001–6000	33,834	26,221	#52
	49,238	37,766	#48
	73,856	57,461	#48
	94,571	75,657	#44
	101,284	80,214	#43

\*As the height above sea level increases, there is less oxygen per cubic ft of air. Therefore, heat input rate should be reduced at higher altitudes.

†Orifices available through your Bryant distributor.

574A

# TYPICAL PIPING AND WIRING

574A

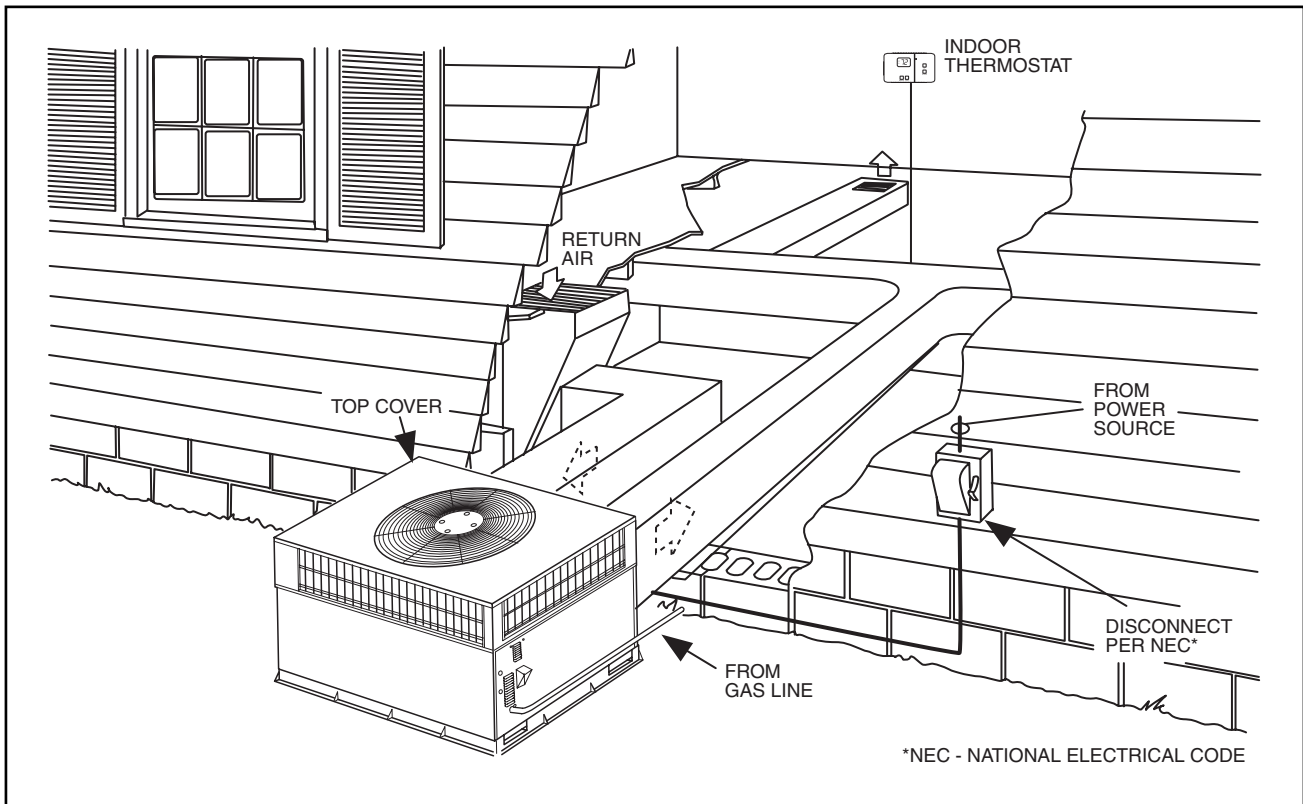
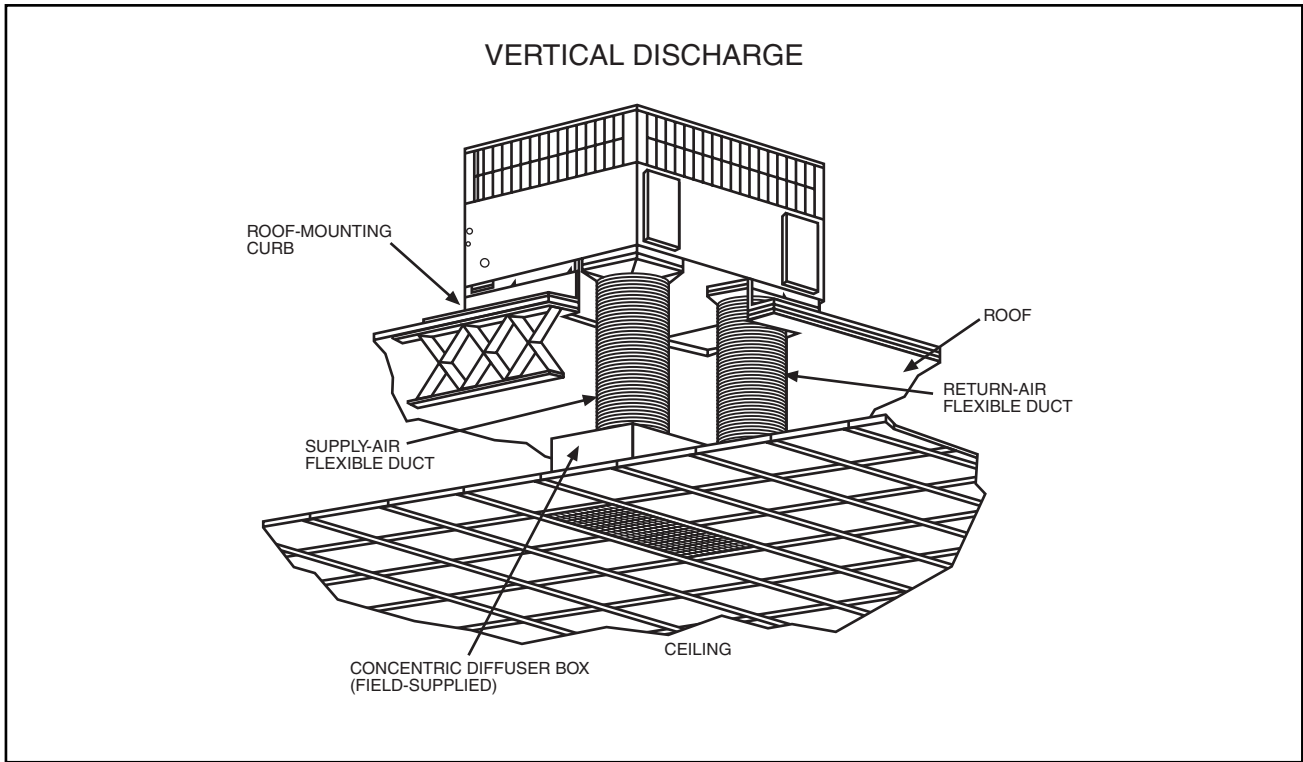

## APPLICATION DATA

**Condensate trap** — A 2-in. condensate trap must be field supplied.

**Ductwork** — Secure downflow discharge ductwork to roof curb. For horizontal discharge applications, attach ductwork to unit with flanges.

**To convert a unit to downflow discharge** — Units are equipped with factory-installed inserts in the down-flow openings. Removal of the inserts is similar to removing an electrical knock-out. Use the duct cover to seal the horizontal discharge openings in the unit. Units installed in horizontal discharge orientation do not require duct covers.

**Airflow** — Units are draw-thru in the cooling mode and blow-thru in the Heating mode.

**Maximum cooling airflow** — To minimize the possibility of condensate blow-off from the evaporator, airflow through the units should not exceed 450 cfm per ton.

**Minimum cooling airflow** — Minimum cooling airflow is 350 cfm per ton.

**Minimum ambient cooling operation temperature** — All standard units have a minimum ambient operating temperature of 40°F. With accessory low ambient temperature kit, units can operate at temperatures down to 0°F.

**Minimum temperature** — Air entering the heat exchanger in heating mode must be a minimum of 50°F continuous and/or 45°F intermittent.

# ELECTRICAL DATA

UNIT SIZE 574A	V-PH-HZ	VOLTAGE RANGE		COMPRESSOR		OFM	IFM	POWER SUPPLY	
		MIN	MAX	RLA	LRA	FLA	FLA	MCA	FUSE OR HACR BKR
024	208/230-1-60	187	253	10.9	54.0	0.9	2.0	16.5/16.5	20/20
030	208/230-1-60	187	253	14.0	72.5	0.9	2.0	20.4/20.4	25/25
036	208/230-1-60	187	253	16.0	88.0	0.9	3.1	24.0/24.0	30/30
042	208/230-1-60	187	253	18.4	104.0	0.9	4.1	28.0/28.0	35/35
048	208/230-1-60	187	253	18.3	109.0	1.5	4.1	28.5/28.5	35/35
060	208/230-1-60	187	253	25.0	148.0	1.5	6.2	39.0/39.0	50/50

## LEGEND

- FLA — Full Load Amps
- LRA — Locked Rotor Amps
- MCA — Minimum Circuit Amps
- MOCP — Maximum Overcurrent Protection
- RLA — Rated Load Amps
- CKT BKR — Circuit Breaker



## NOTES:

1. In compliance with NEC (National Electrical Code) requirements for multimotor and combination load equipment (refer to NEC Articles 430 and 440), the overcurrent protective device for the unit shall be Power Supply fuse. Canadian units may be fuse or circuit breaker.
2. Minimum wire size is based on 60 C copper wire. If other than 60 C wire is used, or if length exceeds wire length in table, determine size from NEC.

574A

# TYPICAL WIRING SCHEMATIC—208/230-1-60 SHOWN

574A

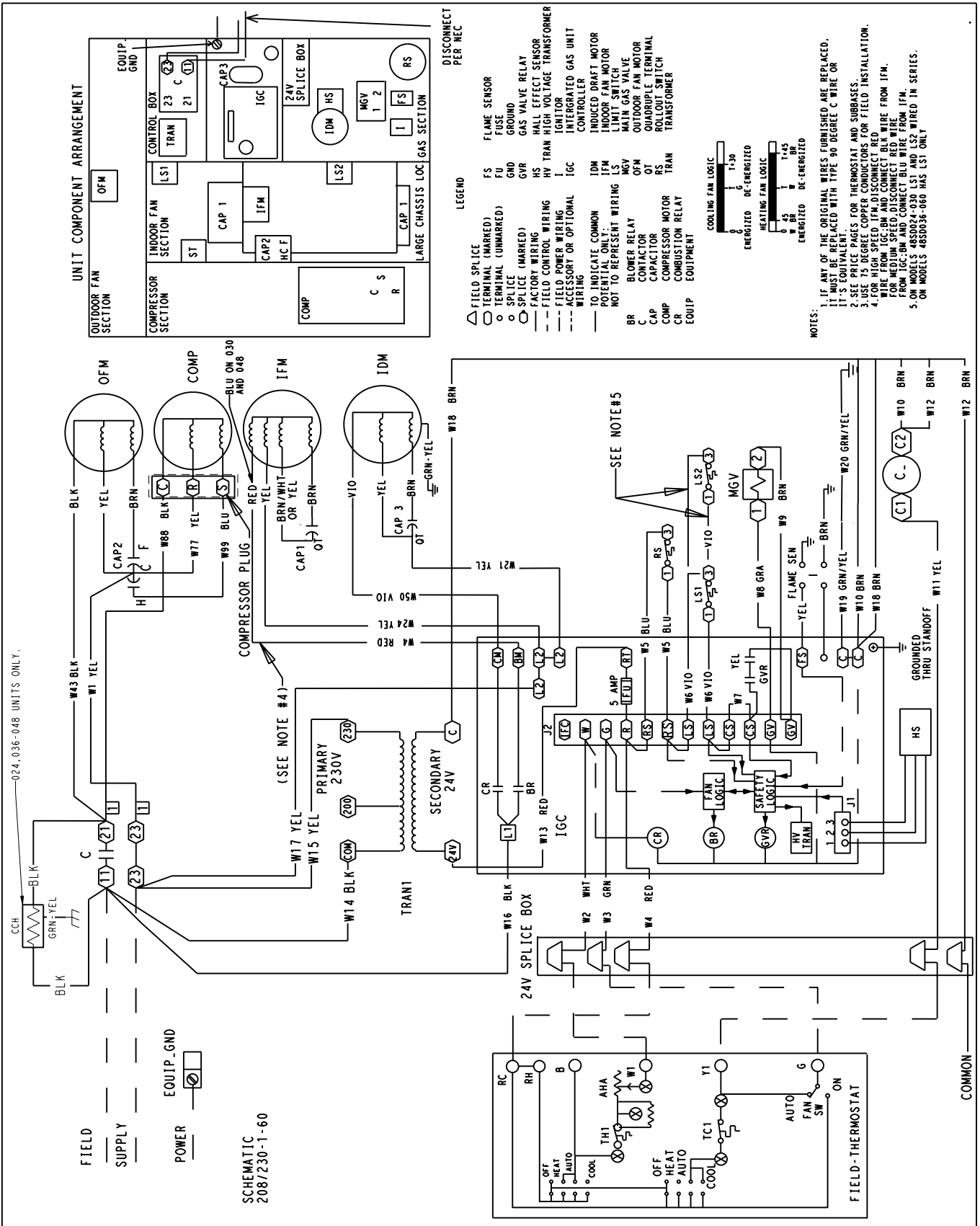

# CONTROLS

## Operating sequence

**Heating** — When the thermostat calls for heating, terminal “W” is energized, starting the induced draft motor. When the hall-effect sensor on the induced-draft motor senses that it has reached the required speed, the burner ignition sequence begins. The indoor (evaporator) fan motor (IFM) is energized 45 seconds after flame is established. When the thermostat is satisfied and “W” is deenergized, the IFM stops after a 45-second time-off delay.

**Cooling** — When the system thermostat calls for cooling, 24 V is supplied to the “Y” and “G” terminals of the thermostat. This completes the circuit to the contactor coil (C) and indoor (evaporator) fan relay (IFR). The normally open contacts of energized C close and complete the circuit through compressor motor (COMP) to outdoor (condenser) fan motor (OFM). Both motors start instantly. The set of normally open contacts of energized IFR close and complete the circuit through IFM. The IFM starts instantly.

On the loss of the thermostat call for cooling, 24 V is removed from both the “Y” and “G” terminals (provided the fan switch is in the “AUTO” position) deenergizing the compressor contactor and opening the contacts supplying power to compressor/OFM. After a 30-second delay, the IFM shuts off. If the thermostat fan selector switch is in the “ON” position, the IFM will run continuously.

**NOTE:** On units with a Time Guard® II device: Once the compressor has started and then stopped, it cannot be restarted again until 5 minutes have elapsed.

# GUIDE SPECIFICATIONS

## Packaged Gas Heating/Electric Cooling Units Constant Volume Application

### HVAC Guide Specifications

Size Range: **2 to 5 Tons, Nominal Cooling  
40,000 to 130,000 Btuh,  
Nominal Heating Input**

Bryant Model Number: 574A

#### Part 1 — General

##### SYSTEM DESCRIPTION

Outdoor rooftop mounted, gas heating/electric cooling unit utilizing a hermetic compressor for cooling duty. Unit shall discharge supply air vertically or horizontally as shown on contract drawings. Condenser fan/coil section shall have a draw-thru design with vertical discharge for minimum sound levels.

##### QUALITY ASSURANCE

- A. Unit shall be rated in accordance with ARI Standards 210/240-03 and 270-95.
- B. Unit shall be designed in accordance with UL Standard 1995.
- C. Unit shall be manufactured in a facility registered to ISO 9001 manufacturing quality standard.
- D. Unit shall be UL listed and c-UL certified as a total package for safety requirements.
- E. Roof curb shall be designed to conform to NRCA Standards.
- F. Insulation and adhesives shall meet NFPA 90A requirements for flame spread and smoke generation.
- G. Cabinet insulation shall meet ASHRAE Standard 62P.

##### DELIVERY, STORAGE AND HANDLING

Unit shall be stored and handled per manufacturer's recommendations.

#### Part 2 — Products

##### EQUIPMENT

###### A. General:

Factory-assembled, single-piece, heating and cooling unit. Contained within the enclosure shall be all factory wiring, piping, controls, refrigerant charge (R-22), and special features required prior to field start-up.

###### B. Unit Cabinet:

1. Unit Cabinet shall be constructed of phosphated, zinc-coated, pre-painted steel capable of with-standing 500 hours in salt spray.
2. Normal service shall be through a single removable cabinet panel.
3. The unit shall be constructed on a rust proof unit base that has an externally trapped, integrated sloped drain.
4. Evaporator fan compartment top surface shall be insulated with a minimum 1/2-in. thick, flexible fiberglass insulation, coated on the air side and retained by adhesive and mechanical means. The evaporator wall sections will be insulated with a minimum semi-rigid foil-faced board capable of being wiped clean. Aluminum foil-faced fiberglass insulation shall be used in the entire indoor air cavity section.
5. Unit shall have a field-supplied condensate trap.

###### C. Fans:

1. The evaporator fan shall be 3-speed, direct-drive, as shown on equipment drawings.
2. Fan wheel shall be made from steel, be double-inlet type with forward curved blades with corrosion resistant finish. Fan wheel shall be dynamically balanced.
3. Condenser fan shall be direct drive propeller type with aluminum blades riveted to corrosion resistant steel spiders, be dynamically balanced, and discharge air vertically.

###### D. Compressor:

1. Fully hermetic compressors with factory-installed vibration isolation.
2. Reciprocating and/or scroll compressors shall be standard on all units.

###### E. Coils:

Evaporator and condenser coils shall have aluminum plate fins mechanically bonded to seamless copper tubes with all joints brazed (Copper/copper and vinyl-coated construction available as option). Tube sheet openings shall be belled to prevent tube wear.

###### F. Heating Section:

1. Induced-draft combustion type with energy saving direct spark ignition system and redundant main gas valve.
2. Induced-draft motors shall be provided with solid-state hall-effect sensor to ensure adequate airflow for combustion.
3. The heat exchangers shall be constructed of aluminized steel for corrosion resistance.
4. Burners shall be of the in-shot type constructed of aluminum coated steel.
5. All gas piping and electric power shall enter the unit cabinet at a single location.

###### G. Refrigerant Components:

Refrigerant components shall be of the fixed orifice feed type.

###### H. Filters:

Filter section shall consist of field-installed, throwaway, 1-in. thick fiberglass filters of commercially available sizes.

###### I. Controls and Safeties:

1. Unit controls shall be complete with a self-contained low voltage control circuit.
2. Compressors shall incorporate a solid-state compressor protector that provides reset capability.

###### J. Operating Characteristics:

1. Unit shall be capable of starting and running at 125°F ambient outdoor temperature per maximum load criteria of ARI Standard 210.
2. Compressor with standard controls shall be capable of operation down to 40°F ambient outdoor temperature.
3. Units shall be provided with fan time delay to prevent cold air delivery before the heat exchanger warms up.
4. Unit shall be provided with 30-second fan time delay after the thermostat is satisfied.



## GUIDE SPECIFICATIONS (CONT)

### K. Electrical Requirements:

All unit power wiring shall enter the unit cabinet at a single location.

### L. Motors:

1. Compressor motors shall be of the refrigerant-cooled type with line-break thermal and current overload protection.
2. All fan motors shall have permanently lubricated bearings, and inherent, automatic reset, thermal overload protection.
3. Condenser fan motor shall be totally enclosed.

### M. Special Features:

1. Louvered Grille:  
Wire grille shall be standard on all units. Louvered grille shall be available as a factory-installed option to provide hail guard and vandalism protection.
2. Coil Options:  
Shall include factory-installed optional copper/copper and vinyl-coated refrigerant coils.
3. Economizer:
  - a. Economizer controls capable of providing free cooling using outside air.
  - b. Equipped with low leakage dampers not to exceed 3% leakage, at 1.0 in. wg pressure differential.
  - c. Spring return motor shuts off outdoor damper on power failure.
4. Flat Roof Curb:  
Curbs shall have seal strip and a wood nailer for flashing and shall be installed per manufacturer's instructions.
5. Manual Outdoor Air Damper:  
Package shall consist of damper, birdscreen, and rainhood which can be preset to admit outdoor air for year-round ventilation.
6. Thermostat:  
To provide for one-stage heating and cooling in addition manual or automatic changeover and indoor fan control.

### 7. Natural-to-Propane Conversion Kit:

Shall be complete with all required hardware to convert to liquid propane (LP) operation at 3.5 in. wg manifold pressure.

### 8. Low Ambient Package:

Shall consist of a solid-state control and condenser coil temperature sensor for controlling condenser-fan motor operation, which shall allow unit to operate down to 0° F outdoor ambient temperature.

### 9. Filter Rack Kit:

Shall provide filter mounting for downflow applications.

### 10. Controls Upgrade Kit:

Shall provide high and low pressure safety protection.

### 11. Square-To-Round Duct Transitions (024-048):

Shall have the ability to convert the supply and return openings from rectangular to round.

### 12. Compressor Protection:

Solid-state control shall protect compressor by preventing "short cycling."

### 13. Crankcase Heater:

Shall provide anti-floodback protection for low-load cooling applications.

### 14. High Altitude Kit:

Shall consist of natural gas orifices to compensate for gas heat operation at 2001 to 6000 ft above sea level.

### 15. Low NOx:

Shall provide NOx reduction to values below 40 nanograms/joule to meet California emission requirements as shipped from factory.

### 16. Compressor Hard Start Kit (single phase units only):

Shall provide additional starting torque for single-phase compressors.