

**EFFICIENT & ECONOMICAL
GAS-FIRED HOT WATER
HOME HEATING**



SERIES 2



BURNHAM SERIES 2 GAS-FIRED HOT WATER BOILER

Quality home heating you can count on

If you're investigating a heating system for your new home, or if you're replacing an old, inefficient, or worn-out boiler, a Burnham® Series 2 gas-fired hot water boiler is the home heating investment that's right for you.



Burnham's Series 2 boiler offers you all the benefits of hot water heat together with the advantages of quality cast iron construction and advanced engineering. When you specify Burnham, you get home heating that is comfortable, economical, and reliable — all from a boiler that's safe, quiet, and field proven in thousands of installations.

High Efficiency Model Available

The high efficiency version of the Series 2 boiler provides annual fuel utilization efficiencies of 84% and is available in four sizes from 62-164 MBH input. In addition to all the standard features included in the

Series 2, this model features an intermittent ignition system and stainless steel flue baffles for even greater heat transfer and efficiency.

Make a Smart Investment

There are few investments you'll ever make that are more important than your heating system. With the guidance of a qualified heating contractor, you can easily customize your heating system and choose options that add comfort and value to your home. Burnham's Series 2 makes heating your home with gas a practical investment today and one you'll appreciate over the years.

Start saving now!

Many old boilers operate at around 60% efficiency.

This means that 40% of your fuel dollars are wasted. A Series 2 boiler, with an annual fuel utilization efficiency (AFUE) of up to 84%, can reduce your heating bills by as much as 28%. Your Series 2 boiler virtually pays for itself in a few short years by saving money spent on fuel the old system is wasting.

Use the following formula (illustrated top right) to compare the Series 2 boiler to the 60% efficiency of a typical 20-year-old boiler.

In the example shown, the homeowner could realize a \$429 savings the first year alone. Check with your contractor to calculate your savings potential.

How to Determine Your Savings

Formula:

Your Current Boiler's Efficiency Rating	X	Your Current Annual Fuel Bill	=	Your Estimated New Fuel Bill
84				

Example:

Your present boiler's efficiency is rated at 60% and your annual fuel bill is \$1500.

60	X	\$1500	=	\$1071
84				

= \$429 Savings

Abundant Hot Water

Today's homeowners need more hot water than ever before, for showers, dishwashers, washing machines, hot tubs, etc. By combining the Series 2 boiler with Burnham's Alliance™ indirect-fired water heater, you'll have sufficient hot water to meet all your needs. The Alliance water heater utilizes the high heating capability of your boiler to provide year-round hot water at a very low operating cost.



Built to Last

Made in the USA — Every Burnham® boiler is made in the U.S.A. All Burnham boiler castings are produced "in-house" to

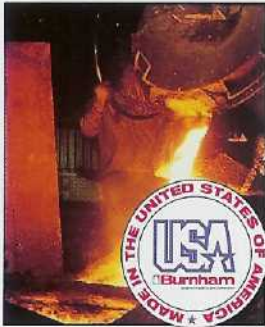

ensure quality and availability. Burnham is the only boiler manufacturer that can make such a claim.

Iron Nipple Seal of Dependability — The sections are joined with iron nipples assuring you of a trouble-free boiler, and Burnham backs it up with a Lifetime Nipple Leakage Warranty on the Series 2 boilers.



Lifetime True-Blue limited warranty — Burnham stands behind every Series 2 boiler with a Lifetime limited warranty on the heat exchanger.



Check These Operating and Safety Features

✓ **Rugged cast iron sections**
Hundreds of heat extracting pins extract the maximum amount of heat, reducing fuel consumption and saving you money.

✓ **Iron couplings called Nipples**
Iron nipples increase the longevity of the boiler. They resist petroleum based chemicals, including antifreeze, which can deteriorate the cheaper rubber type gaskets substituted for metal push nipples in some competitors' boilers.



- ✓ **Vertical flueways**
Natural draft created by your chimney provides unsurpassed reliability of operation.
- ✓ **Fuel saving vent damper**
This automatically closes the flue to prevent heat from escaping up the chimney after the burner shuts off and reopens it again before the burner comes on.
- ✓ **Fuel saving intermittent ignition system**
Intermittent ignition is available on all sizes of the Series 2 boiler firing natural gas or LP gas. Coupled with a redundant gas valve, the system safely shuts down on loss of pilot flame in less than one second.
- ✓ **Honeywell controls**
Honeywell controls are the highest quality brand name controls assuring reliability and availability.

✓ **Stainless steel burners**
Stainless steel, unlike aluminized steel, ensures long life with no rusting.

✓ **Step-opening gas valve**
This type of gas valve enables the boiler to start on low fire and continue on to high fire safely and smoothly providing quiet ignition and long life. The valve is concealed inside the boiler jacket, hidden from children and safe from accidental bumps and tampering.

✓ **Flame roll-out switch**
A FRS is a thermally activated switch, located near the burner, that senses temperature in the vestibule. For example, if the flue-ways within the boiler become blocked or restricted, the flame roll-out switch will automatically shut off gas flow to prevent combustion byproducts from spilling into your home and to prevent damage to your boiler.

✓ **Blocked vent switch**
This switch safely shuts down the boiler in the event the chimney or vent system becomes blocked, by sensing excessive heat exiting the draft hood.

✓ **Concealed Controls**
All controls are hidden under the boiler jacket to prevent damage and tampering.

✓ **Combustible floor certified**
The Series 2 boiler can be installed on any floor surface in your home without worry. (Do not install on carpeting.)

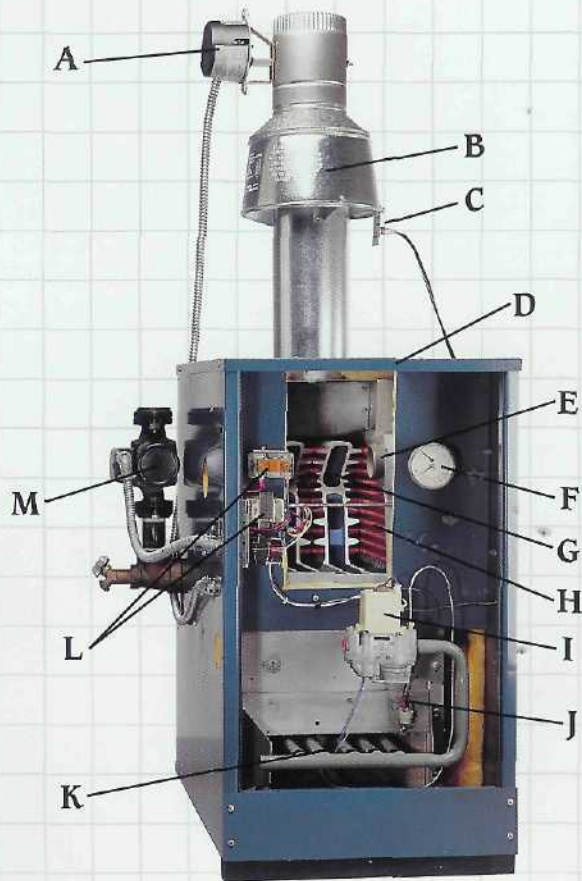

- A. Vent damper
- B. Draflthood
- C. Blocked vent switch
- D. Deluxe insulated jacket
- E. Iron nipple joins sections
- F. Pressure temperature gauge
- G. Durable cast iron sections for long life
- H. Pinned heating surface for maximum heat extraction
- I. Concealed step opening gas valve (SmartValve™ shown)
- J. Flame roll-out switch
- K. Stainless steel burners
- L. Brand name quality controls
- M. Self lubricating circulator never needs oil

 **Honeywell SmartValve™**
 This new electronic ignition system provides its own ignition source to light the pilot only when there is a need for heat. This eliminates extra wiring and a separate ignition control system.



One Source for Total Comfort

Since 1873, Burnham has been dedicated to leading the hydronics heating industry through product development and engineering expertise. With over 125 years of proven dependability, and the broadest product line, Burnham is the one company you can rely on for your complete home heating comfort.

Why settle for just a high efficiency Burnham boiler, when you can have a complete Burnham system? Improve upon your new boiler's efficiency with Burnham's complete line of system components including: the Alliance family of indirect water heaters, radiant heat pipe and accessories from Burnham Radiant Heating Company, low profile baseboard, modern radiators, and electronic controls. Burnham offers all the components for a complete home comfort system along with the industry's most comprehensive technical support team. Now is the time to make Burnham the one source for your total hydronic heating system.

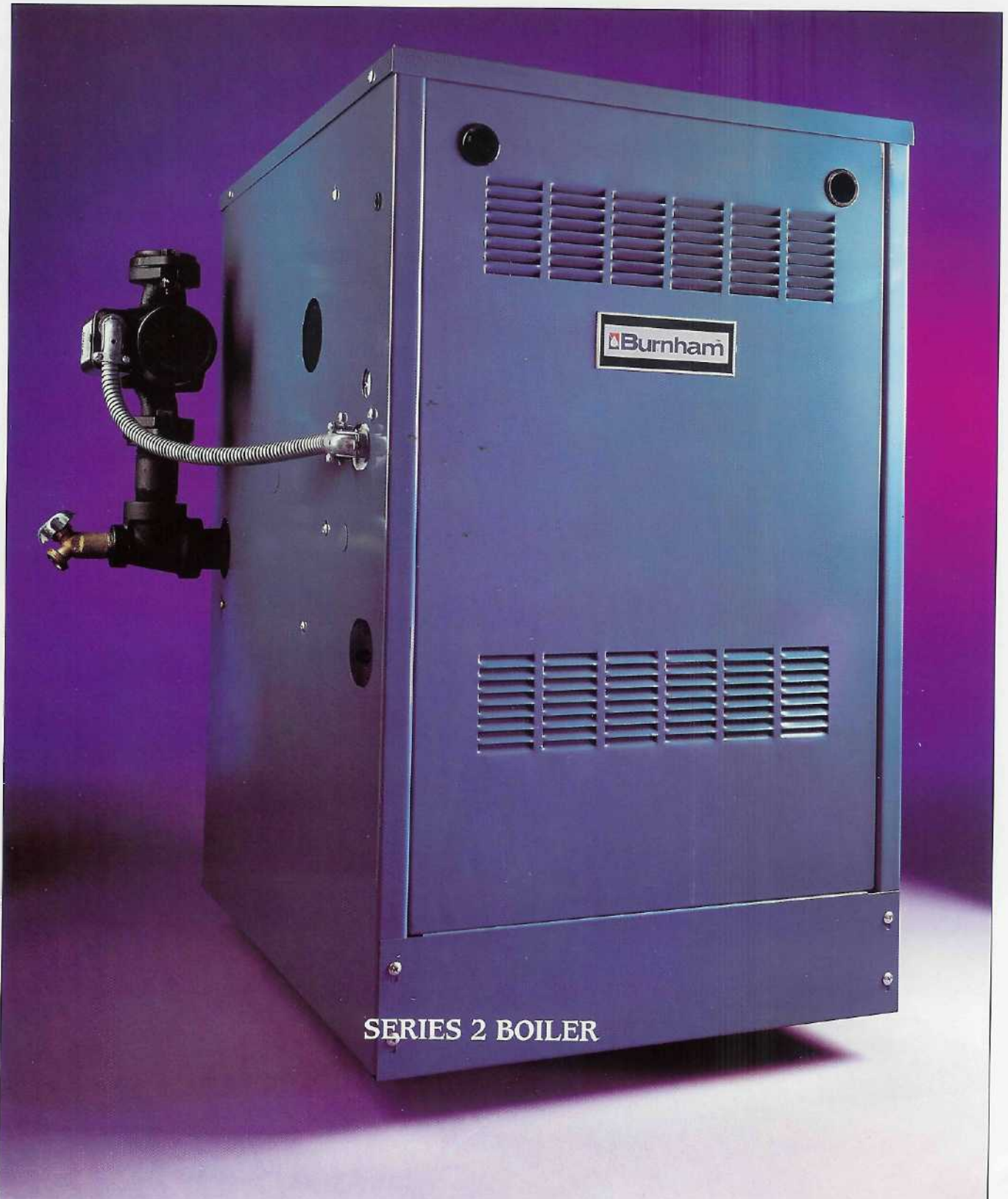

SERIES 2 BOILER

SPECIFICATIONS

SERIES 2 RATINGS Natural Gas or LP Gas



BOILER NUMBER	INPUT MBH (2)	DOE HEATING CAPACITY MBH (1)	I=B=R NET RATING MBH (3)	AFUE % (1)		APPROX. SHIPPING WEIGHT (LBS.)	MINIMUM RECOMMENDED CHIMNEY SIZE ROUND Dia. (In.) x Ht. (Ft.)
				STANDING PILOT	(EI) SMARTVALVE		
202*	37.5	31	27	80.0	82.3	222	4 x 15
202X*	50	42	37	80.2	83.2	272	4 x 15
203*	62	52	45	80.0	82.6	272	4 x 15
204*	96	80	70	80.1	82.3	316	5 x 15
205*	130	108	94	80.2	82.0	364	6 x 15
206*	164	136	118	80.3	81.7	424	6 x 15
207*	198	163	142	80.4	81.4	468	7 x 15
208*	232	191	166	80.4	81.2	524	7 x 15
209*	266	218	190	80.5	80.9	560	8 x 15
210*	299	244	212	80.7	80.6	618	8 x 15
203H*	62	52	45	N/A	84.0	274	4 x 15
204H*	96	80	70	N/A	84.0	319	5 x 15
205H*	130	108	94	N/A	84.0	368	6 x 15
206H*	164	136	118	N/A	84.0	429	6 x 15

* When ordering, add suffix 'N' to indicate natural gas. Substitute 'P' when ordering propane. Add 'C' to indicate 24 volt standing pilot. Add 'S' to indicate Smartvalve electronic ignition. Smartvalve is standard on 2H. See Burnham Trade Price Sheet for full model number explanation.

Water Only - 30 PSI working pressure

- DOE heating capacity and AFUE are based on U.S. Government standard tests.
- Inputs shown are for installations at sea level and elevations up to 2,000 ft. For elevations above 2,000 ft., ratings should be reduced at the rate of four percent (4%) for each 1,000 ft. above sea level.
- Net I=B=R ratings shown are based on normal I=B=R piping and pick up allowance of 1.15. Consult Burnham for installations having unusual piping and pick up requirements such as intermittent system of operation, extensive piping systems, etc.

MODEL	A	B	C	D
202	18-3/4	10-3/4	4	50-3/8
202X	20	12	4	50-3/8
203	20	12	4	50-3/8
204	23-1/4	15-1/4	5	51-7/8
205	26-1/2	18-1/2	6	53-3/4
206	29-3/4	21-3/4	6	53-3/4
207	33	25	7	56-3/4
208	36-1/4	28-1/4	7	56-3/4
209	39-1/4	31-1/2	8	59-1/4
210	42-3/4	34-3/4	8	59-1/4

Deluxe Insulated Jacket
Circulator & Piping - Shipped Loose
Pressure Temperature Gauge
Drain Valve
High Limit
Circulator Relay
Transformer and Junction Box
100% Shut-off Combination
Step Opening Gas Valve
Stainless Steel Burners
Safety Relief Valve
Draffhood
Vent Damper
Blocked Vent Switch
Flame Roll-Out Switch

Dimensions (in inches) and Standard Equipment

