

PTAC CONDENSATE DISPOSAL PUMP KIT INSTALLATION INSTRUCTIONS

Condensate Disposal Pump Kit

The internal condensate pump serves as an effective means for disposing of condensate generated during heat pump operation by transferring it to the indoor coil. The warm coil surface and the warm room air help in evaporation of the condensate while adding humidity to the room. As with any equipment of this type, the addition of this kit will decrease the sensible heating capacity of the unit. This kit is not intended for use in seacoast or corrosive environments.

NOTE: Under extreme high humidity conditions, the internal condensate pump may not be able to dispose of all the condensate produced, and condensate would then drip from the outside of the wall sleeve. If this condensation is unacceptable, then a drain system (including factory approved drain kit for the wall sleeve) should be installed.

WARNING

Disconnect electrical power source before installing these kits. Failure to do so may result in injury or death from electrical shock. The unit "OFF" switch does not disconnect all power to the unit.

Preparation

1. Remove front by rotating bottom outward and then lifting up and out from chassis.
2. Unplug and remove the PTAC chassis from the wall sleeve. Move the chassis where the front and back of the chassis can be easily accessed.
3. Remove the discharge screen by unscrewing two screws holding the screen to the blower panel. Set screen aside (Figure 1).

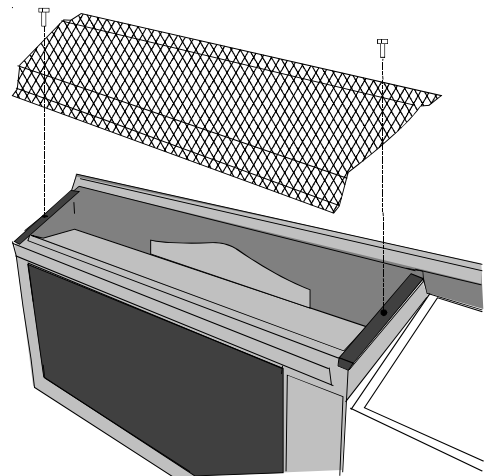

Figure 1

- Lift the blower panel approximately 10 inches by unscrewing two screws holding the blower panel to the chassis and lift upward being careful not to pinch heater wires (Figure 2).

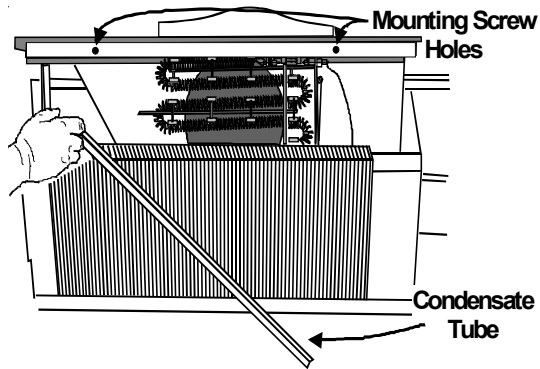

Figure 2

- Using the short leg of the condensate tube push out the 1/2 inch diameter knockout on the back wall of the styrofoam scroll. The condensate tube should protrude through the partition panel by 1-3/4 inches. Rotate the condensate tube so the tube lays flat on the coil (Figures 2 & 3).

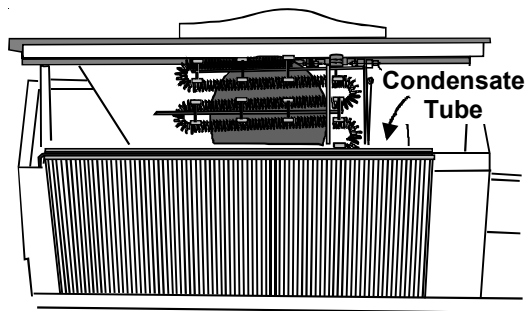

Figure 3

- Orient the condensate tube on the coil so when the blower panel is lowered the condensate tube fits snugly into the raised embossment of the blower panel.
- Make sure the holes in the condensate tube are *facing inward* toward the blower wheel.
- Lower the blower panel over the condensate tube and screw the blower panel to the chassis with the existing screws. Replace the discharge screen and screw the screen to the blower panel with the existing screws.
- Using the overflow tube holder and the overflow tube, hold the tube with the metal holder and screw the holder to the partition panel with the provided 1/2 inch #8 screw (Figures 4 & 5).

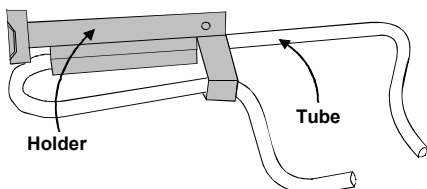

Figure 4

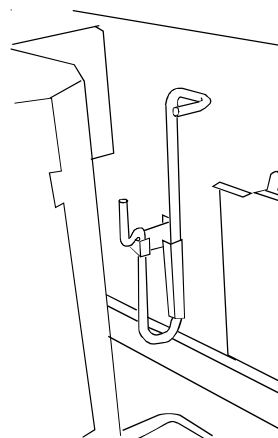

Figure 5

- Place the pump bracket onto the end of the pump by feeding the pump cord through the hole in the bracket and pushing the bracket onto the threads of the pump. Slide the supplied washer onto the threads of the pump. Screw the pump nut onto the threads of the pump and tighten the nut so that the bracket is secure against the pump (Figure 6).

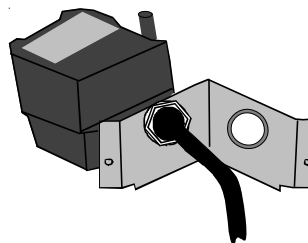

Figure 6

- Orient the pump in the back left corner of the basepan and screw the pump bracket to the basepan with the provided two 1/2 inch #8 screws (Figure 7).

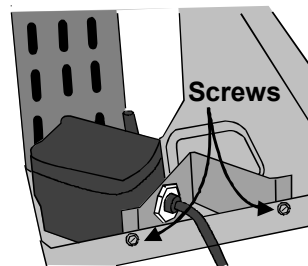

Figure 7

- Remove the protective adhesive backing from the plastic U clip and mount the U clip to the plastic condenser shroud in approximately the position shown (Figure 8).
- Attach the p-clamp to the brace with the screw provided. (Figure 8).
- Place one of the hose clamps over one end of the 16 inch vinyl hose. Place the same end over the barbed discharge tube of the pump assembly. Place a hose clamp on the other end of the 16 inch hose. Place this same end over the shorter leg of the overflow tube and secure the hose with the hose clamp (Figure 8).

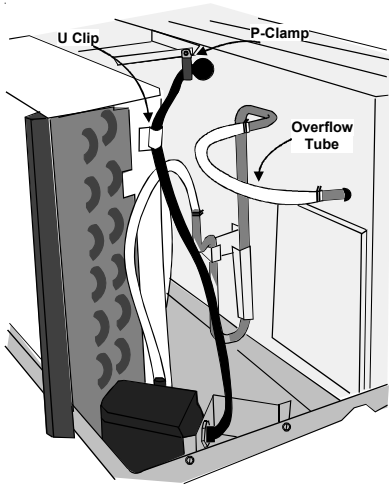

Figure 8

15. Place a hose clamp over one end of the 11 inch long hose. Push this same end over the longer leg of the overflow tube and secure with the hose clamp. Place another hose clamp over the other end of the 11 inch hose. Push this same end over the condensate tube protruding out from the back of the partition panel and secure with the hose clamp (Figure 8).
16. Route the condensate pump cord through the U clip on the condenser shroud, through the p-clamp attached to the brace, and then through the hole in the panel where the compressor wires are routed through the panel. **NOTE:** The permagum may have to be removed to feed the wires through the panel, make sure wires have no slack and replace the permagum back into place to prevent air leaks (Figures 8 and 9).

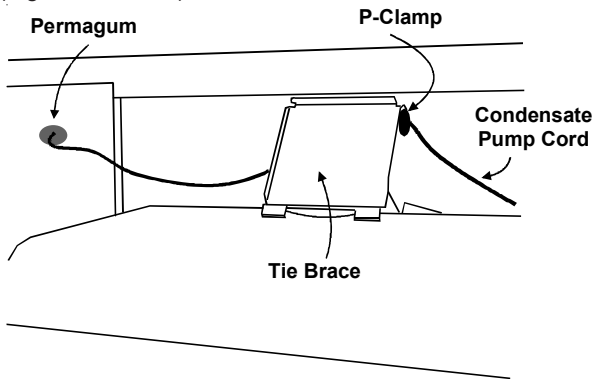

Figure 9

17. To gain access inside the control panel, remove the knobs and escutcheon. Remove the three screws holding the panel in position. Tilt the control panel forward, being careful not to pinch any wires (Figure 10).
18. Lift the control panel up so the control panel is free of its hinges. Orient the control panel so there is easy access for mounting components to the control panel (Figures 10 and 11).

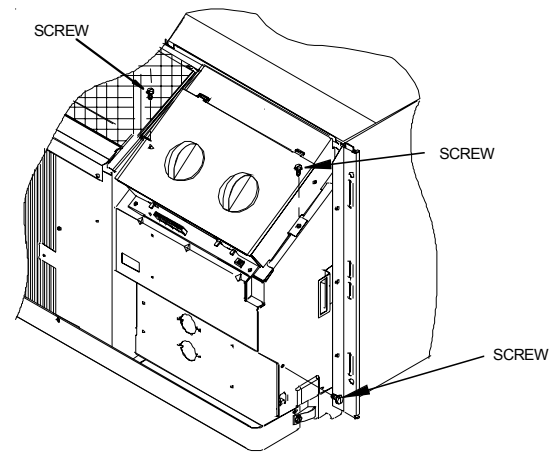

Figure 10

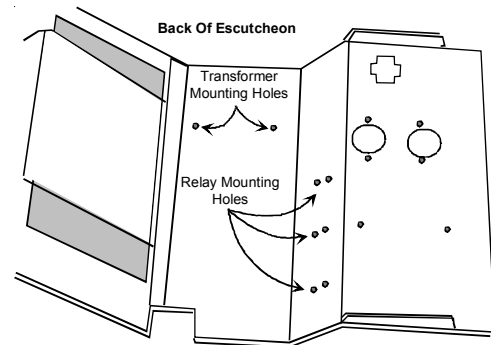

Figure 11

19. Using two #8 screws that are provided, screw the transformer to the control panel in the transformer mounting holes provided in the panel (Figure 11).
20. Mount the relay in one of the three relay mounting holes in the control panel making sure that the threaded stud is in the smaller hole and the metal tab is in the adjacent larger hole. Screw the provided nut onto the threaded stud from the opposite side of the control panel (Figure 11).
21. Disconnect the RD33, VT12, and BK19 wires from the control board and connect the YL5 (where RD33 was connected), YL3 (where VT12 was connected), and YL1 (where BK19 was connected). Connect RD33 to the piggyback terminal of YL5, VT12 to the piggyback terminal of YL3, and BK19 to the piggyback terminal of YL1. Make sure the OR8 wire is connected from the #6 terminal of the relay to 24 volt terminal of the transformer (Figure 12).
22. For 208 volt applications move the WH6 wire terminal from the 240 volt terminal of the transformer to the 208 terminal of the transformer.
23. Units that have a Power Vent or Power Door Kit already installed in the chassis should refer to Figure 13 for proper wiring of the condensate pump kit. Use the second set of transformer holes to mount the transformer.
24. Units that have a 2 stage heater already installed in the chassis should refer to Figure 14 for proper wiring of the condensate pump kit.
25. Units that have a Power Vent or Power Door Kit and a two stage heater already installed in the chassis should refer to Figure 15 for proper wiring of the condensate pump kit.
26. Install the basepan drain plug into the basepan drain hole by pushing it up into the drain hole from the bottom of the basepan. This will defeat the thermostatic controlled drain valve. The basepan drain is located left of the outside coil (as viewed from the back of the unit).

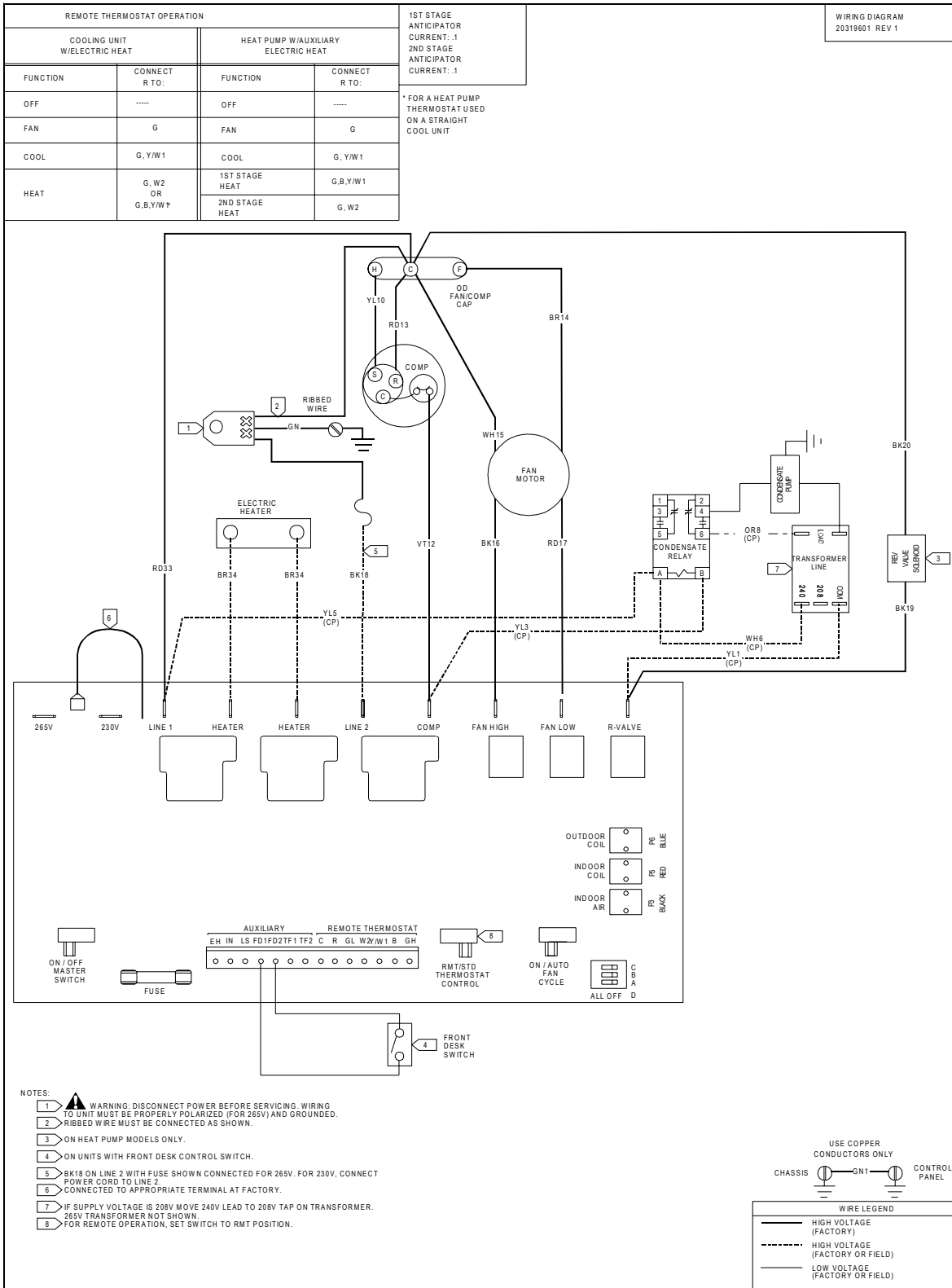

Figure 12
Standard Unit with Single Stage Heat

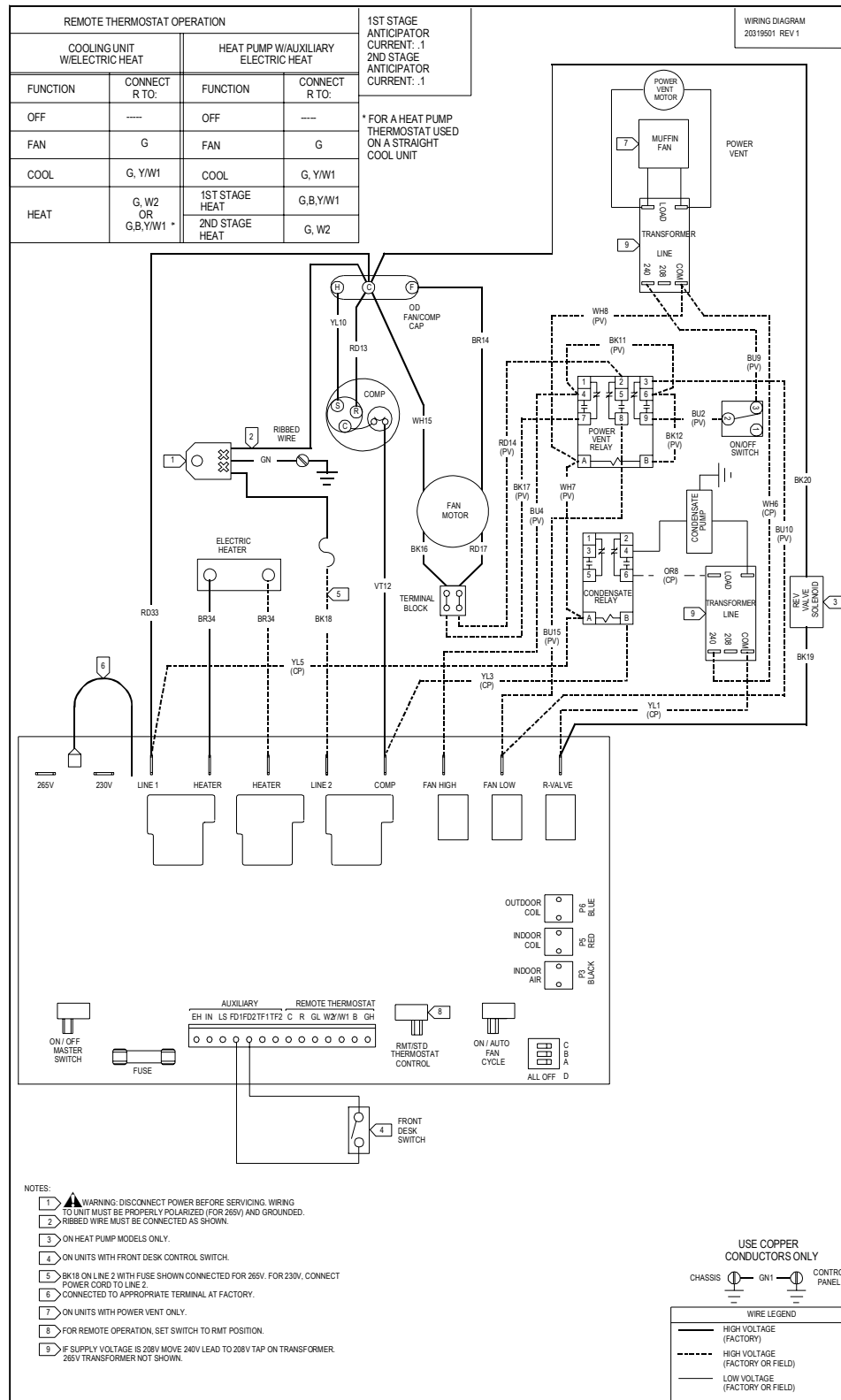

Figure 13
Single Stage Heat with Power Vent or Power Door

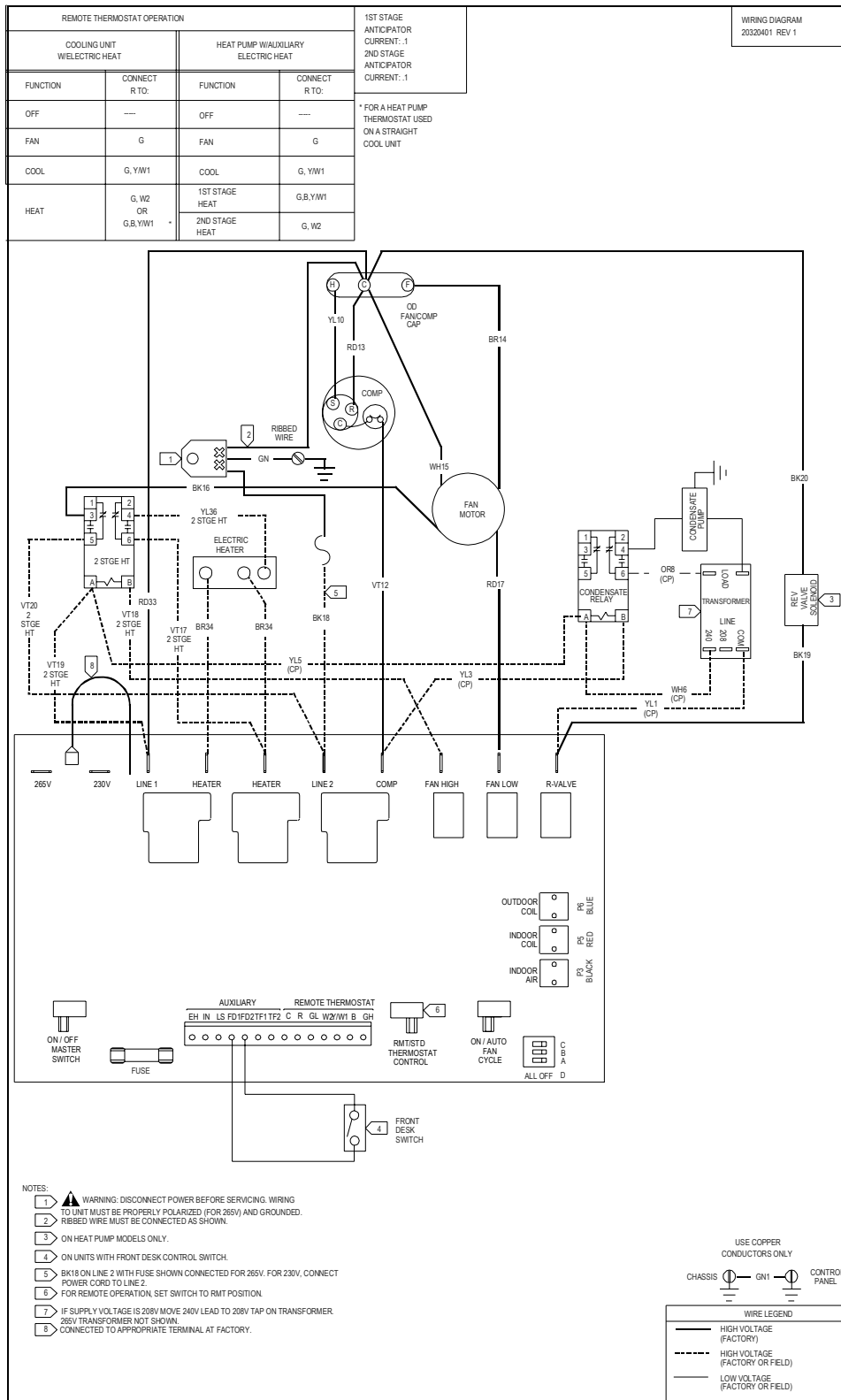

Figure 14
Standard Unit with Two Stage Heat

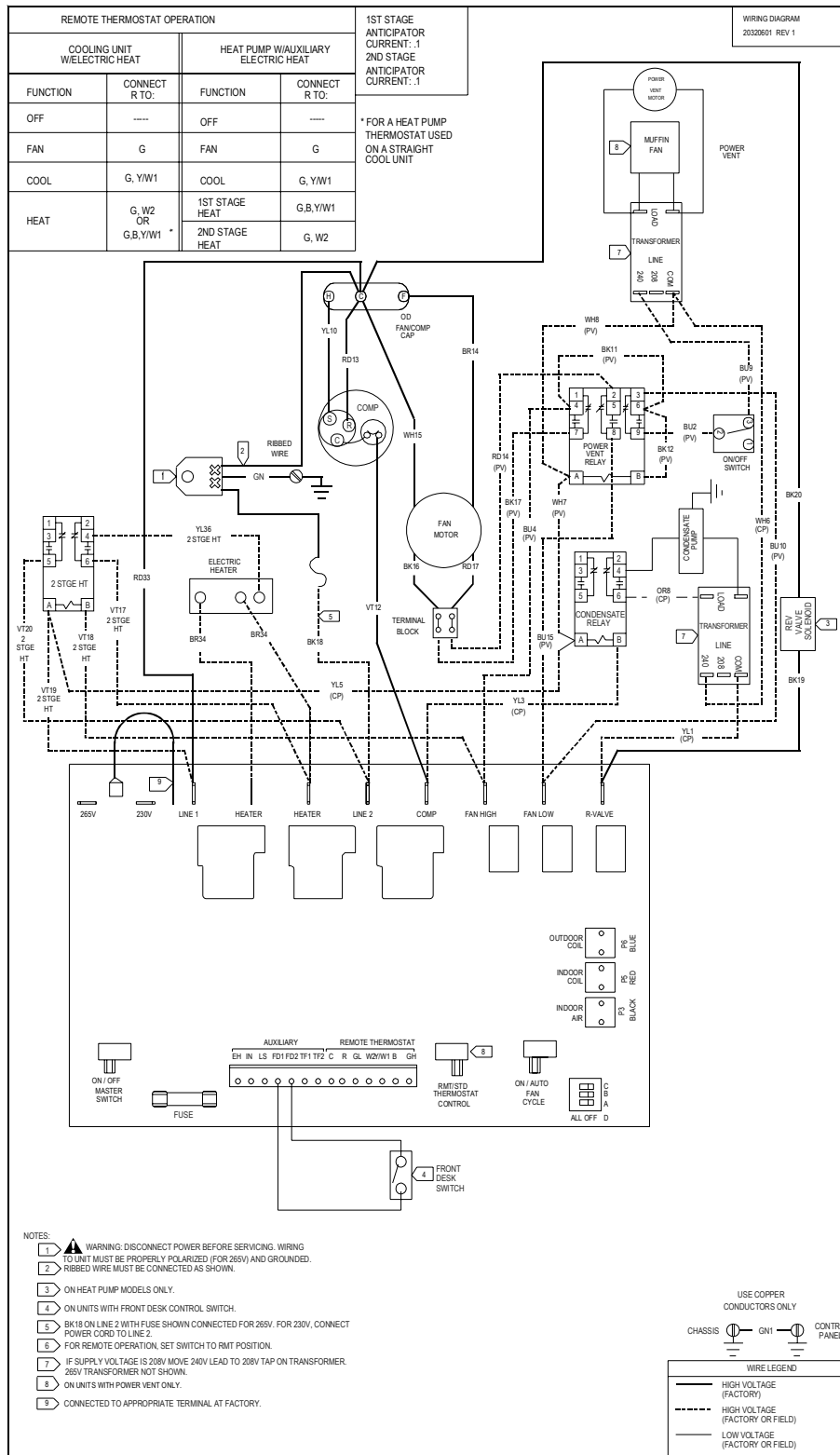

Figure 15

Two Stage Heat with Power Vent or Power Door