

**SPLIT TYPE
ROOM AIR CONDITIONER**

**WALL MOUNTED^{type}
INVERTER**

SERVICE INSTRUCTION

Models	Indoor unit	Outdoor unit
	ASU9RLQ	AOU9RLQ
	ASU12RLQ	AOU12RLQ
	ASU18CL	AOU18CL
	ASU18RL	AOU18RL

Refrigerant
R410A

CONTENTS

1. SPECIFICATION

ASU9/12RLQ, AOU9/12RLQ, ASU18C/RL, AOU18C/RL.....	01-01
---------------------------------------------------	-------

2. DIMENSIONS

ASU9/12RLQ, AOU9/12RLQ.....	02-01
ASU18C/RL, AOU18C/RL.....	02-02

3. REFRIGERANT SYSTEM DIAGRAM

ASU9/12RLQ, AOU9/12RLQ.....	03-01
ASU18C/RL, AOU18C/RL.....	03-02

4. CIRCUIT DIAGRAM

ASU9/12RLQ, AOU9/12RLQ.....	04-01
ASU18C/RL, AOU18C/RL.....	04-02

5. DESCRIPTION OF EACH CONTROL OPERATION

1. COOLING OPERATION.....	05-01
2. HEATING OPERATION.....	05-02
3. DRY OPERATION.....	05-03
4. AUTO CHANGEOVER OPERATION.....	05-04
5. INDOOR FAN CONTROL.....	05-05
6. OUTDOOR FAN CONTROL.....	05-07
7. LOUVER CONTROL.....	05-08
8. COMPRESSOR CONTROL.....	05-09
9. TIMER OPERATION CONTROL.....	05-10
10. ELECTRONIC EXPANSION VALVE CONTROL.....	05-12
11. TEST OPERATION CONTROL.....	05-12
12. PREVENT TO RESTART FOR 3 MINUTES (3 MINUTES ST).....	05-12
13. FOUR-WAY VALVE EXTENSION SELECT.....	05-12
14. AUTO RESTART.....	05-12
15. MANUAL AUTO OPERATION (Indoor unit body operation).....	05-13
16. FORCED COOLING OPERATION.....	05-13
17. COMPRESSOR PREHEATING.....	05-13
18. COIL DRY OPEARTION CONTROL.....	05-13
19. DEFROST OPERATION CONTROL.....	05-14
20. OFF DEFROST OPERATION CONTROL.....	05-16
21. VARIOUS PROTECTIONS.....	05-17

6. REFRIGERANT CAUTION -R410A-

- 1. R410A TOOLS..... 06-01
- 2. PRECAUTION FOR INSTALLATION..... 06-02
- 3. PRECAUTION FOR SERVICING..... 06-04
- 4. NEW REFRIGERANT R410A..... 06-05
- 5. DEFFERENCE FROM CONVENTIONAL MODEL(R22) AND PRECAUTIONS..... 06-08

7. TROUBLE SHOOTING

- 1. WHEN THE UNIT DOES NOT OPERATE AT ALL..... 07-01
- 2. SELF DIAGNOSIS FUNCTION..... 07-02
- 3. TROUBLE SHOOTING METHOD
- 4. SELF-DIAGNOSIS FUNCTION AND CHECKING POINTS..... 07-03
- 5. SERIAL SIGNAL DIAGNOSIS..... 07-07
- 6. IPM PROTECTION..... 07-08
- 7. TROUBLE SHOOTING OF REFRIGERANT CYCLE..... 07-09

8. APPENDING DATA

- 1. JUMPER SETTING OF INDOOR UNIT AND OUTDOOR UNIT..... 08-01
- 2. OUTDOOR UNIT PRESSURE VALUE AND TOTAL ELECTRIC
CURRENT CURVE..... 08-02
- 3. THERMISTOR RESISTANCE VALUES..... 08-06
- 4. CAPACITY/INPUT DATA..... 08-07

9. REPLACEMENT PARTS

- 1. EXPLODED VIEW..... 09-01
- 2. INVERTER ASSEMBLY SPECIFICATION..... 09-07

10. INSTALLATION MANUAL

WALL MOUNTED type INVERTER

1 . SPECIFICATIONS

SPECIFICATIONS

MODEL NAME			ASU9RLQ AOU9RLQ	ASU12RLQ AOU12RLQ	ASU18CL AOU18CL	ASU18RL AOU18RL				
POWER SOURCE	PHASE		Ph	1	1	1	1			
	FREQUENCY		Hz	60	60	60	60			
	VOLTAGE		V	208-230	208-230	208-230	208-230			
COOLING PERFORMANCE	CAPACITY (230V)		kW	2.64 (1.05~3.51)	3.51 (1.11~4.26)	5.28 (1.62~5.58)	5.28 (1.62~5.58)			
			Btu /h	9,000 (3,600~12,000)	12,000 (3,800~14,500)	18,000 (5,500~19,000)	18,000 (5,500~19,000)			
	POWER CONSUMPTION (230V)		W	670 (200~1,200)	960 (200~1,500)	1,730 (250~2,000)	1,730 (250~2,000)			
			W /W	3.93	3.66	3.05	3.05			
	EER		Btu /(h.W)	13.4	12.5	10.4	10.4			
			Btu /(h.W)	21.00	21.00	19.00	19.00			
	SEER		A	3.2	4.5	7.7	7.7			
			%	90	93	98	98			
	MAXIMUM CURRENT		A	6.0	7.0	9.0	9.0			
			L /hr	1.3	1.8	2.8	2.8			
	MOISTURE REMOVAL		Pt/h	2.7	3.8	5.9	5.9			
			OPERATING NOISE (SOUND PRESSURE)		INDOOR UNIT		HI	dB	39	41
	INDOOR UNIT				ME	dB	34	35	38	38
					LO	dB	29	29	32	32
					QUIET	dB	20	20	25	25
OUTDOOR UNIT		dB	47	47	50	50				
		CAPACITY		kW	3.51 (0.87~5.28)	4.68 (0.90~6.18)	-	6.30 (1.32~8.52)		
POWER CONSUMPTION				Btu /h	12,000 (3,000~18,000)	16,000 (3,000~21,000)	-	21,600 (4,600~29,000)		
		W	830 (200~1,800)	1,250 (200~2,140)	-	1,930 (250~2,930)				
COP		W /W	4.25	3.75	-	3.28				
		Btu /(h.W)	14.5	12.8	-	11.2				
HSPF		Btu /(h.W)	11.00	10.55	-	10.00				
		RUNNING CURRENT		A	3.9	5.7	-	8.6		
POWER FACTOR				%	92	95	-	98		
		MAXIMUM CURRENT		A	8.5	10.0	-	13.5		
OPERATING NOISE (SOUND PRESSURE)				INDOOR UNIT		HI	dB	40	41	-
		ME	dB			35	35	-	37	
		LO	dB			28	28	-	32	
		QUIET	dB			21	21	-	27	
OUTDOOR UNIT		dB	47	48	-	50				
		COMPRESSOR		TYPE	-	Rotary	Rotary	Rotary	Rotary	
OUTPUT				W	750	750	1,100	1,100		
		AIR CIRCULATION (FAN MODE)		INDOOR UNIT		m3 /h	560	595	700	700
cfm	329					374	412	412		
OUTDOOR UNIT				m3 /h	2,060	1,850	2,000	2,000		
				cfm	1,211	1,088	1,176	1,176		
STARTING CURRENT		A	3.9	5.7	7.7	8.6				
		MINIMUM CIRCUIT AMPACITY		A	10	12	16	16		
MAXIMUM OVERCURRENT PROTECTION				A	20	20	20	20		
		DESIGN PRESSURE		HIGH SIDE	PSI(MPa)	450(3.10)	450(3.10)	450(3.10)	450(3.10)	
LOW SIDE				PSI(MPa)	240(1.65)	240(1.65)	240(1.65)	240(1.65)		
		PERMISSIBLE OUTDOOR TEMPERATURE		COOLING		°F	14~115	14~115	14~115	14~115
°C	-10~46					-10~46	-10~46	-10~46		
HEATING				°F	5~75	5~75	-	5~75		
				°C	-15~24	-15~24	-	-15~24		

SPECIFICATIONS

MODEL NAME				ASU9RLQ AOU9RLQ	ASU12RLQ AOU12RLQ	ASU18CL AOU18CL	ASU18RL AOU18RL			
INSTALLATION	CONNECTING METHOD			-	Flare	Flare	Flare	Flare		
	PIPE SIZE	LIQUID SIDE	mm	6.35	6.35	6.35	6.35			
			in.	1/4	1/4	1/4	1/4			
		GAS SIDE	mm	9.52	9.52	12.7	12.7			
			in.	3/8"	3/8"	1/2"	1/2"			
	STANDARD PIPE LENGTH			m	7.5	7.5	7.5	7.5		
				ft.	25	25	25	25		
	MAXIMUM PIPE LENGTH			m	20	20	20	20		
				ft.	66	66	66	66		
	CHARGE LESS PIPE LENGTH			m	15	15	15	15		
				ft.	49	49	49	49		
	AMOUNT OF ADDITIONAL CHARGE			g /m	20	20	20	20		
				oz. /ft.	3 /16	3 /16	3 /16	3 /16		
	MAXIMUM HEIGHT DIFFERENCE			m	15	15	15	15		
ft.				49	49	49	49			
NUMBER OF WIRE			-	4	4	4	4			
DRAIN HOSE LENGTH			mm	580	580	580	580			
			in.	22-13/16"	22-13/16"	22-13/16"	22-13/16"			
WEIGHT	NET	INDOOR UNIT		kg	9.5	9.5	9	9		
				lbs.	21	21	20	20		
		OUTDOOR UNIT		kg	35	37	40	40		
				lbs.	77	82	88	88		
	GROSS (PACKAGING WEIGHT)	INDOOR UNIT		kg	12	12	12	12		
				lbs.	26	26	26	26		
		OUTDOOR UNIT		kg	39	41	44	44		
				lbs.	86	90	97	97		
OTHER INDICATION	MAIN UNIT DIMENSIONS		INDOOR UNIT		HEIGHT	mm	283	283	275	275
					in.	11-1/8"	11-1/8"	10-13/16"	10-13/16"	
					WIDTH	mm	790	790	790	790
					in.	31-1/8"	31-1/8"	31-1/8"	31-1/8"	
			OUTDOOR UNIT		DEPTH	mm	230	230	215	215
					in.	9-1/16"	9-1/16"	8-7/16"	8-7/16"	
					HEIGHT	mm	540	540	578	578
					in.	21-1/4"	21-1/4"	22-3/4"	22-3/4"	
			OUTDOOR UNIT		WIDTH	mm	790	790	790	790
					in.	31-1/8"	31-1/8"	31-1/8"	31-1/8"	
					DEPTH	mm	290	290	300	300
					in.	11-7/16"	11-7/16"	11-13/16"	11-13/16"	
	PACKAGE DIMENSIONS		INDOOR UNIT		HEIGHT	mm	316	316	290	290
					in.	12-7/16"	12-7/16"	11-7/16"	11-7/16"	
					WIDTH	mm	835	835	835	835
					in.	32-7/8"	32-7/8"	32-7/8"	32-7/8"	
			OUTDOOR UNIT		DEPTH	mm	360	360	345	345
					in.	14-3/16"	14-3/16"	13-9/16"	13-9/16"	
					HEIGHT	mm	625	625	648	648
					in.	24-5/8"	24-5/8"	25-1/2"	25-1/2"	
OUTDOOR UNIT			WIDTH	mm	919	919	910	910		
			in.	36-3/16"	36-3/16"	35-13/16"	35-13/16"			
			DEPTH	mm	385	385	380	380		
			in.	15-3/16"	15-3/16"	14-15/16"	14-15/16"			
Refrigerant	KIND OF REFRIGERANT			-	R410A	R410A	R410A	R410A		
	AMOUNT OF CHARGING			kg	0.95	1.05	1.15	1.15		
				lbs.	2-2/16	2-5/16	2-9/16	2-9/16		

WALL MOUNTED type INVERTER

2 . DIMENSIONS

DIMENSIONS

Models : ASU9RLQ / AOU9RLQ
ASU12RLQ / AOU12RLQ

(unit : mm)

INDOOR UNIT

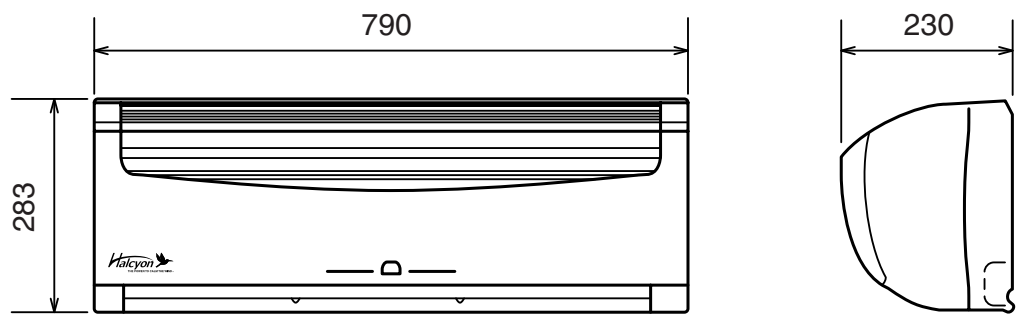

OUTDOOR UNIT

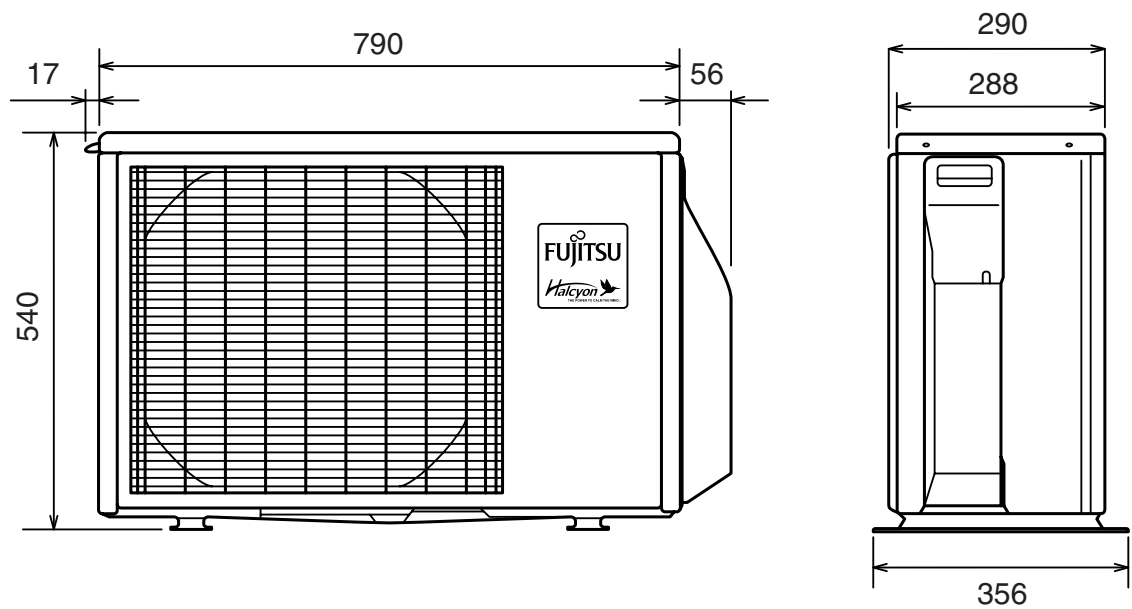

DIMENSIONS

Models : ASU18CL / AOU18CL
ASU18RL / AOU18RL

(unit : mm)

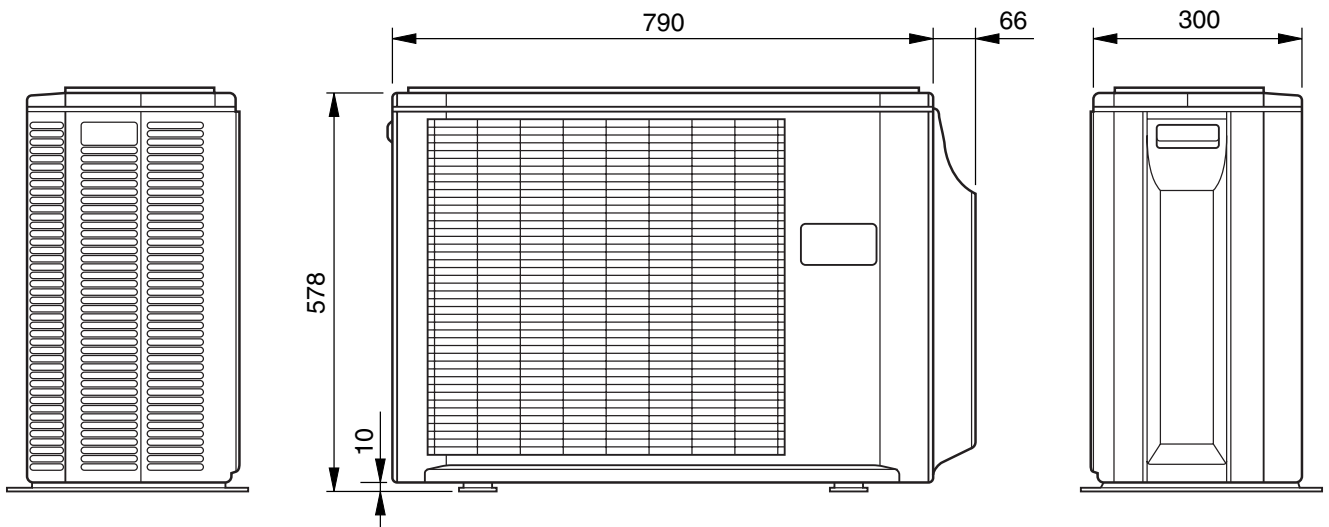
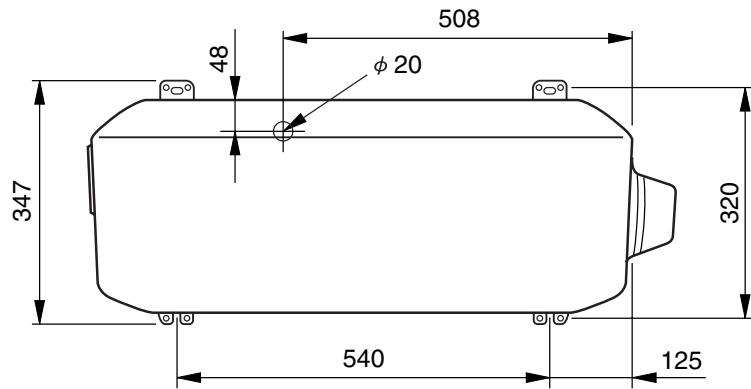
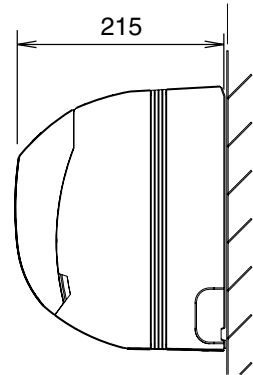
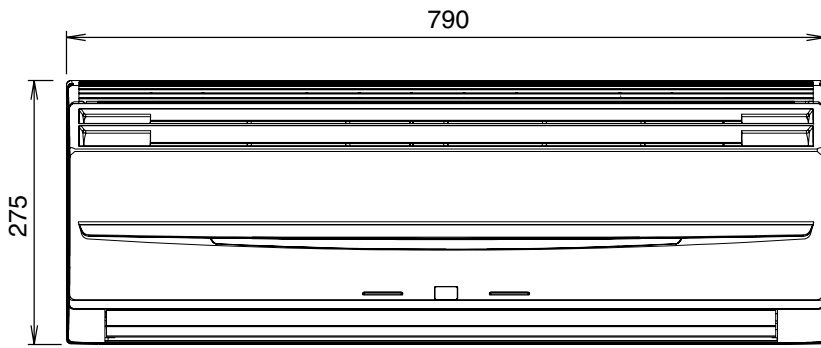

WALL MOUNTED type INVERTER

3 . REFRIGERANT SYSTEM DIAGRAM

REFRIGERANT SYSTEM DIAGRAM

Models : ASU9RLQ / AOU9RLQ
ASU12RLQ / AOU12RLQ

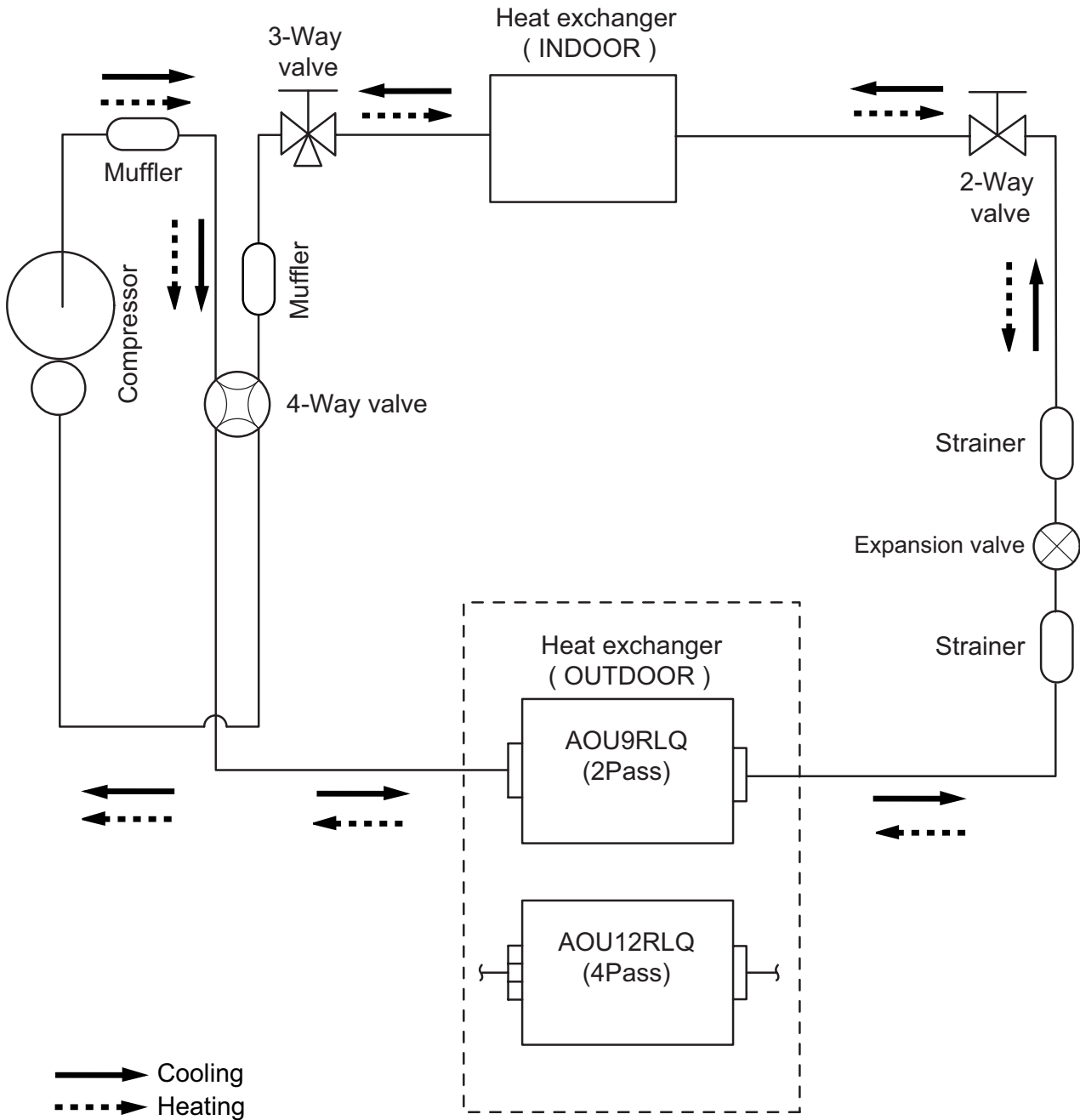

REFRIGERANT SYSTEM DIAGRAM

Models : ASU18CL / AOU18CL
ASU18RL/ AOU18RL

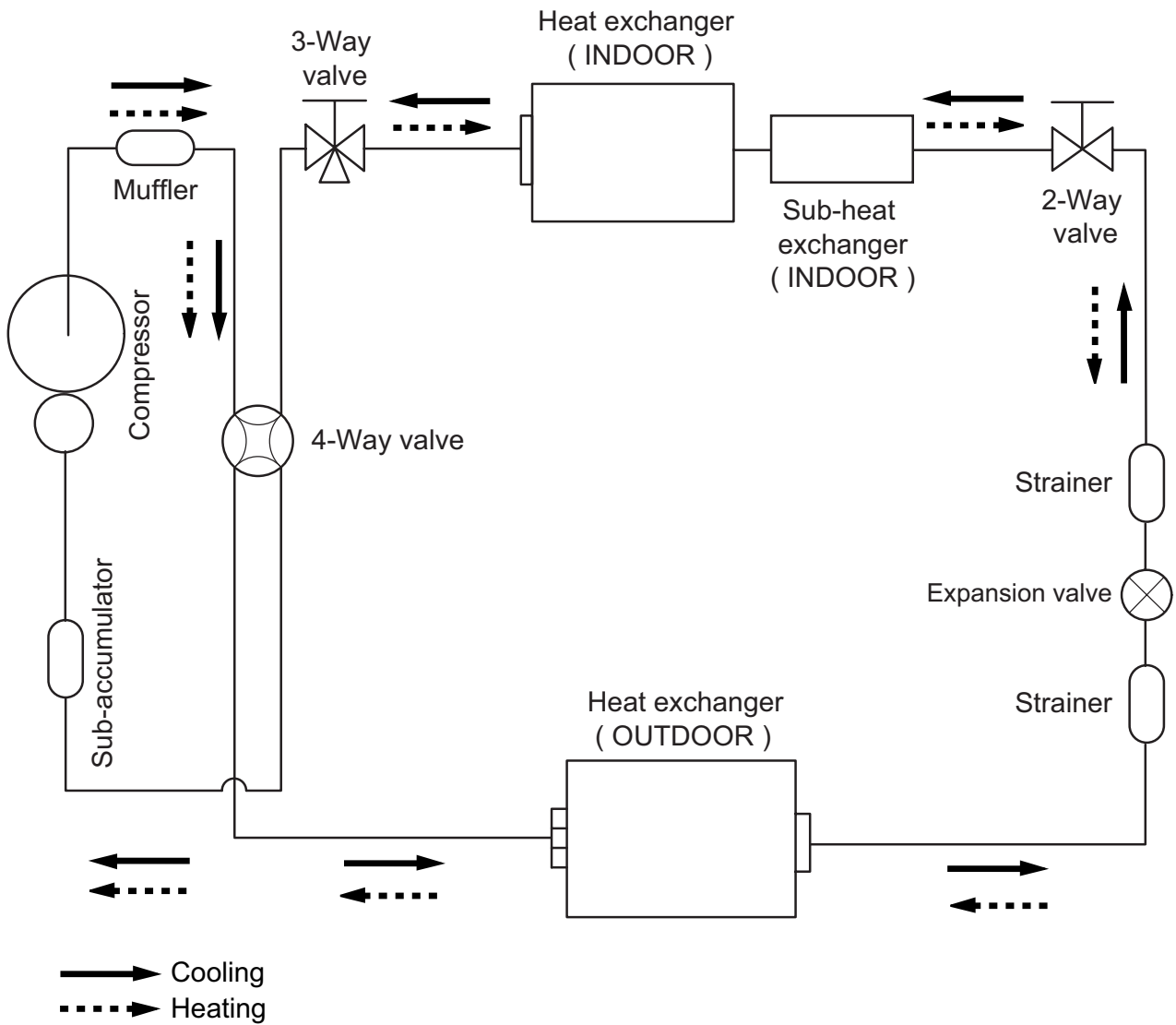

WALL MOUNTED type INVERTER

4 . CIRCUIT DIAGRAM

CIRCUIT DIAGRAM

Models : ASU9RLQ / AOU9RLQ
ASU12RLQ AOU12RLQ

INDOOR UNIT

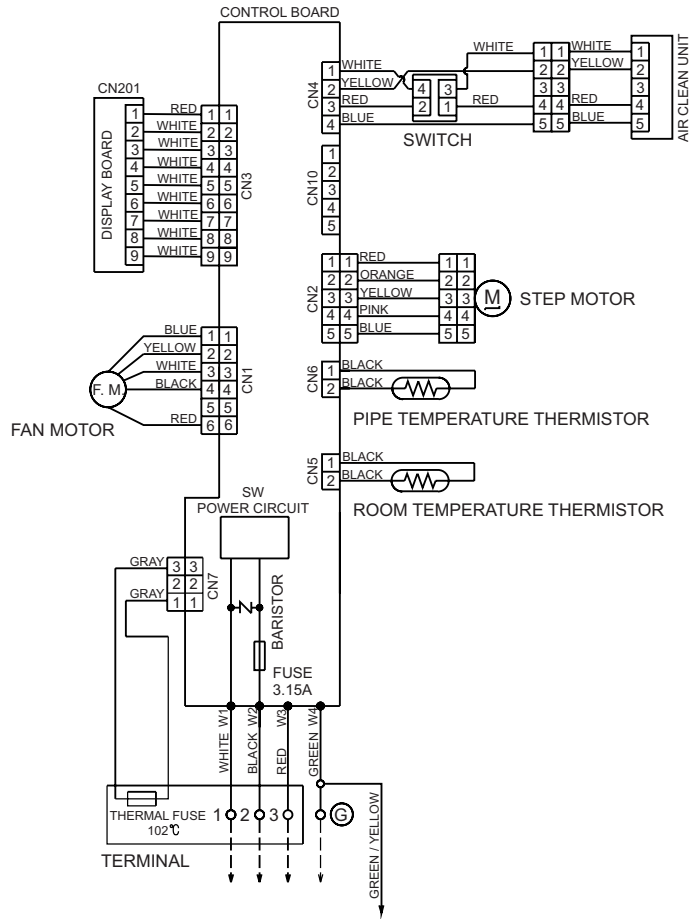

OUTDOOR UNIT

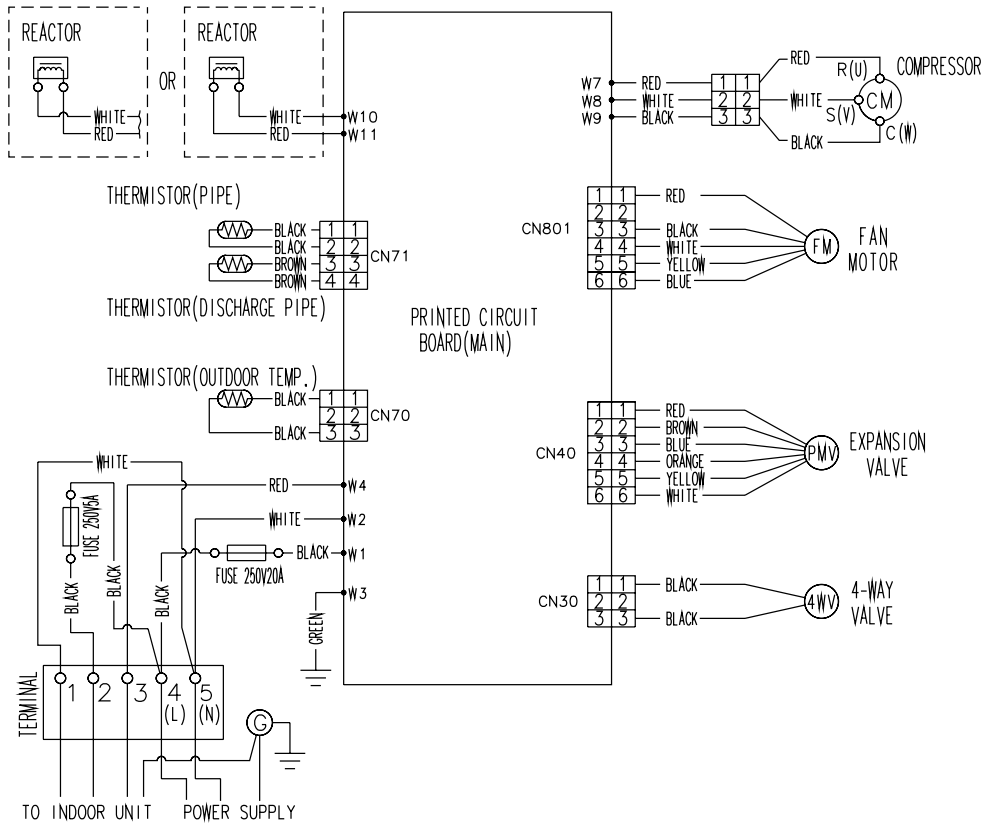

CIRCUIT DIAGRAM

Models : ASU18CL / AOU18CL
ASU18RL / AOU18RL

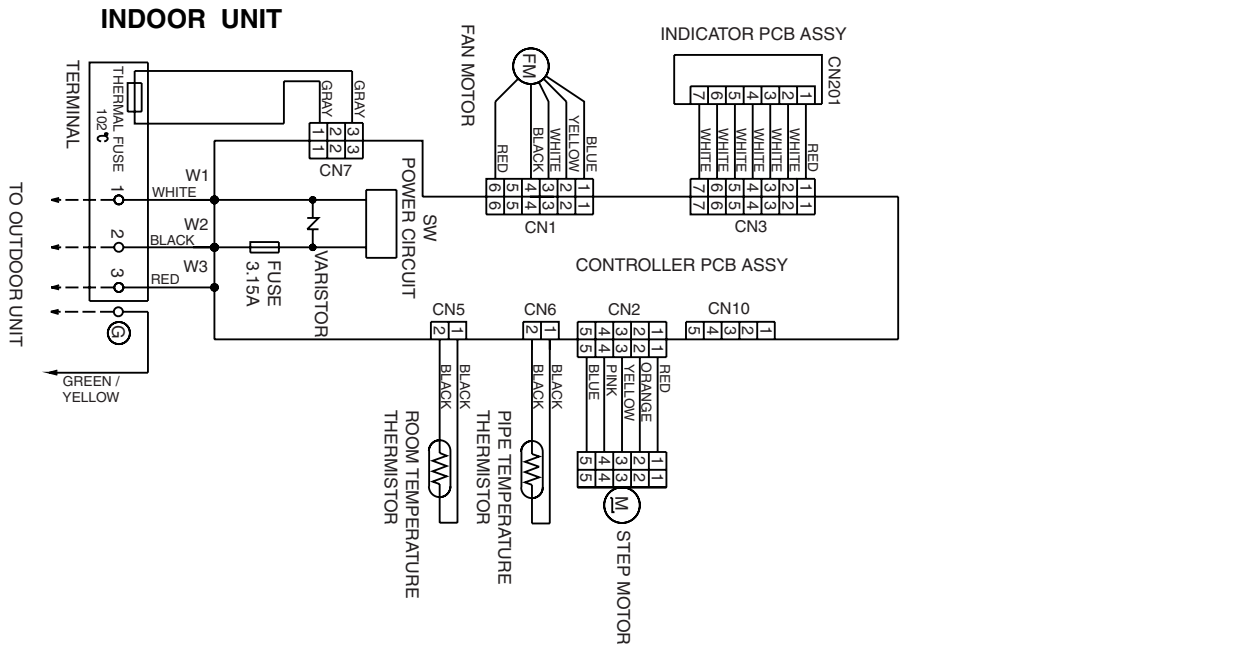

OUTDOOR UNIT

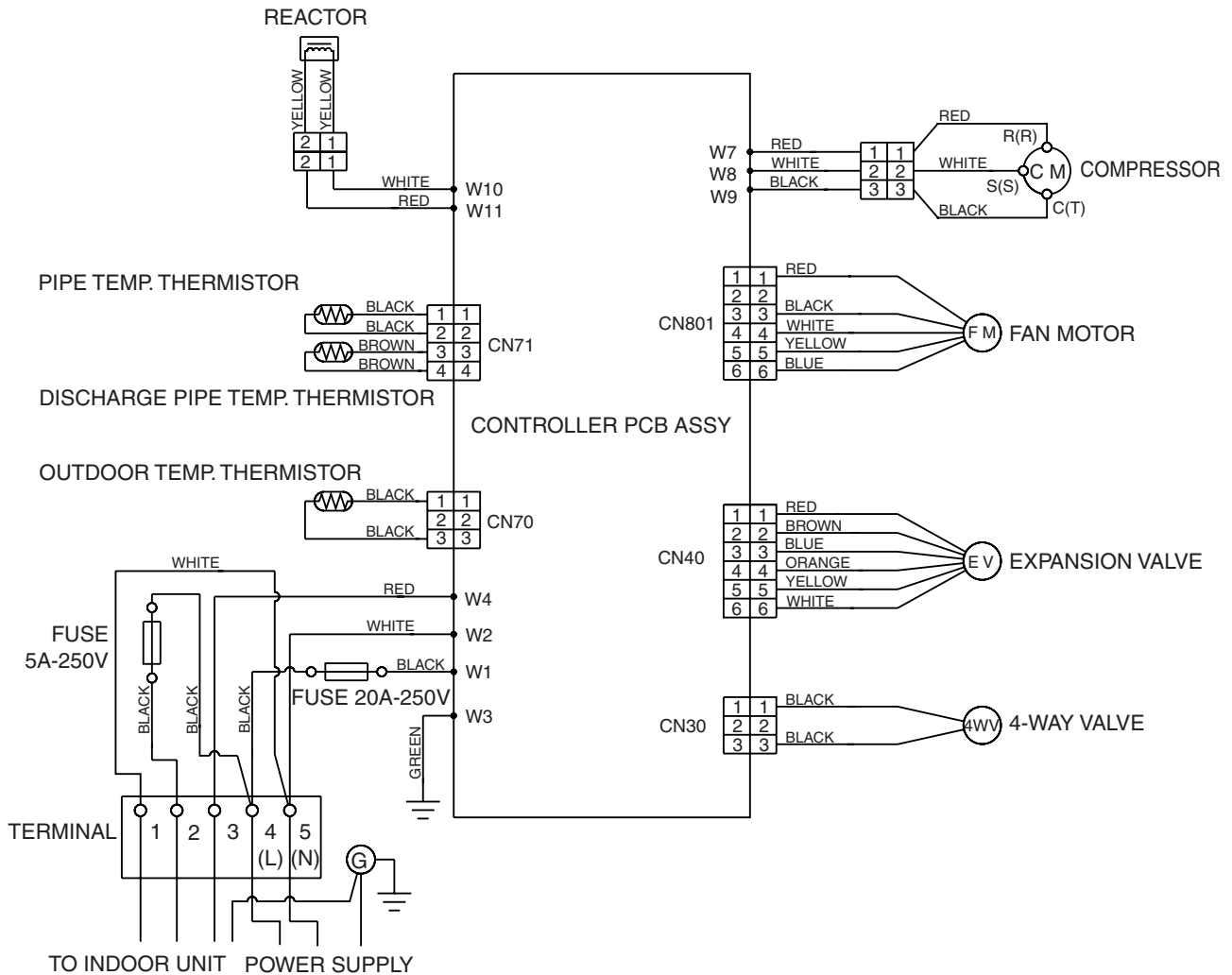

WALL MOUNTED type INVERTER

5 . DESCRIPTION OF EACH CONTROL OPERATION

1. COOLING OPERATION

1-1 COOLING CAPACITY CONTROL

A sensor (room temperature thermistor) built in the indoor unit body will usually perceive difference or variation between a set temperature and present room temperature, and controls the operation frequency of the compressor.

* If the room temperature is 4°F(2°C) higher than a set temperature, the compressor operation frequency will attain to maximum performance.

* If the room temperature is 5°F(2.5°C) lower than a set temperature, the compressor will be stopped.

* When the room temperature is between +4°F(+2°C) to -5°F(-2.5°C) of the setting temperature, the compressor frequency is controlled within the range shown in Table1. However, the maximum frequency is limited in the range shown in Figure 1 based on the fan speed mode and the outdoor temperature.

(Table 1 : Compressor Frequency Range)

	minimum frequency	maximum frequency II	maximum frequency I
ASU9RLQ	18Hz	61Hz	80Hz
ASU12RLQ	18Hz	80Hz	96Hz
ASU18CL	18Hz	70Hz	90Hz
ASU18RL	18Hz	70Hz	90Hz

(Fig. 1 : Limit of Maximum Frequency based on Outdoor Temperature)

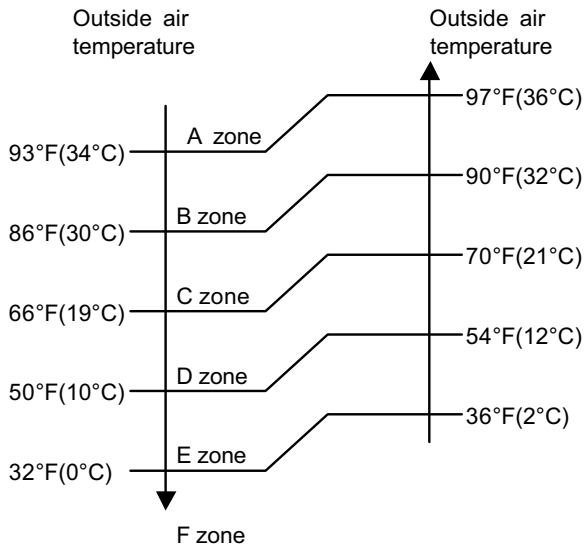

		Hi	Me	Lo	Quiet
9RLQ	A zone	80Hz	61Hz	51Hz	33Hz
	B zone	80Hz	61Hz	51Hz	33Hz
	C zone	80Hz	61Hz	51Hz	33Hz
	D zone	51Hz	42Hz	36Hz	27Hz
	E zone	51Hz	42Hz	36Hz	27Hz
	F zone	51Hz	42Hz	36Hz	27Hz
12RLQ	A zone	96Hz	61Hz	51Hz	33Hz
	B zone	96Hz	61Hz	51Hz	33Hz
	C zone	96Hz	61Hz	51Hz	33Hz
	D zone	57Hz	42Hz	36Hz	27Hz
	E zone	57Hz	42Hz	36Hz	27Hz
	F zone	57Hz	42Hz	36Hz	27Hz
18CL	A zone	90Hz	45Hz	42Hz	30Hz
	B zone	90Hz	45Hz	42Hz	30Hz
	C zone	90Hz	45Hz	42Hz	30Hz
	D zone	58Hz	38Hz	34Hz	24Hz
	E zone	58Hz	38Hz	34Hz	24Hz
	F zone	58Hz	38Hz	34Hz	24Hz
18RL	A zone	90Hz	45Hz	42Hz	30Hz
	B zone	90Hz	45Hz	42Hz	30Hz
	C zone	90Hz	45Hz	42Hz	30Hz
	D zone	58Hz	38Hz	34Hz	24Hz
	E zone	58Hz	38Hz	34Hz	24Hz
	F zone	58Hz	38Hz	34Hz	24Hz

When the compressor operates for 30 minutes continuously at over the maximum frequency II, the maximum frequency is changed from Maximum Frequency I to Maximum Frequency II.

The room temperature is controlled 2°F(1°C) lower than the setting temperature for 40 minutes after starting the operation.

After 40 minutes, it is controlled based on the normal setting temperature.

2. HEATING OPERATION

2-1 HEATING CAPACITY CONTROL

A sensor (room temperature thermistor) built in the indoor unit body will usually perceive difference or variation between a set temperature and present room temperature, and controls the operation frequency of the compressor.

- * If the room temperature is lower by 6°F(3°C) than a set temperature, the compressor operation frequency will attain to maximum performance.
- * If the room temperature is higher 5°F(2.5°C) than a set temperature, the compressor will be stopped.
- * When the room temperature is between +4°F(+2°C) to -6°F(-3°C) of the setting temperature, the compressor frequency is controlled within the range shown in Table2. However, the maximum frequency is limited in the range shown in Figure 2 based on the fan speed mode and the outdoor temperature.

(Table 2 : Compressor Frequency Range)

	minimum frequency	maximum frequency
ASU9RLQ	18Hz	130Hz
ASU12RLQ	18Hz	130Hz
ASU18CL	-	-
ASU18RL	18Hz	119Hz

(Fig.2 : Limit of Maximum Frequency based on Outdoor Temperature)

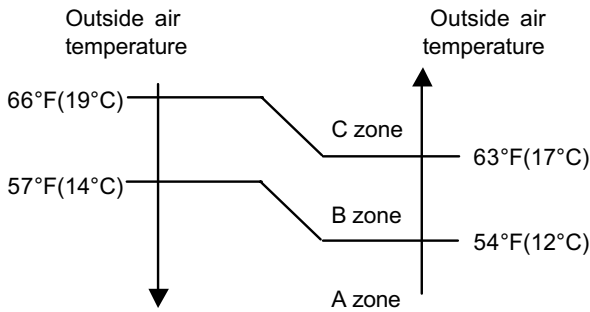

		Hi	Me	Lo	Quiet
9RLQ	A zone	130Hz	96Hz	80Hz	68Hz
	B zone	130Hz	96Hz	80Hz	54Hz
	C zone	130Hz	96Hz	80Hz	45Hz
12RLQ	A zone	130Hz	96Hz	80Hz	68Hz
	B zone	130Hz	96Hz	80Hz	54Hz
	C zone	130Hz	96Hz	80Hz	45Hz
18CL	A zone	-	-	-	-
	B zone	-	-	-	-
	C zone	-	-	-	-
18RL	A zone	119Hz	90Hz	70Hz	58Hz
	B zone	119Hz	90Hz	70Hz	58Hz
	C zone	119Hz	90Hz	70Hz	58Hz

- * The room temperature is controlled 4°F(2°C) higher than the setting temperature for 60 minutes after starting the operation. After 60 minutes, it is controlled based on the normal setting temperature.

3. DRY OPERATION

3-1 INDOOR UNIT CONTROL

The compressor rotation frequency shall change according to the temperature, set temperature, and room temperature variation which the room temperature sensor of the indoor unit body has detected as shown in the Table 3. However, after the compressor is driven, the indoor unit shall run at operation frequency of 58Hz, for a minute.

(Table 3 : Compressor frequency)

	Operating frequency
ASU9RLQ	33Hz
ASU12RLQ	33Hz
ASU18CL	24Hz
ASU18RL	24Hz

(Fig.3 : Compressor Control based on Room Temperature)

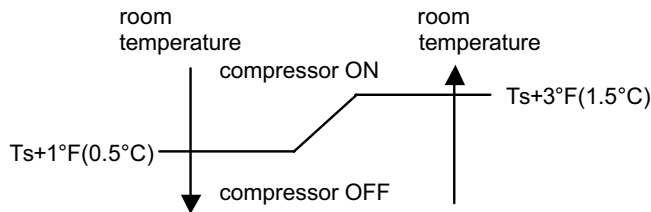

(Fig.4 : Indoor Fan Control)

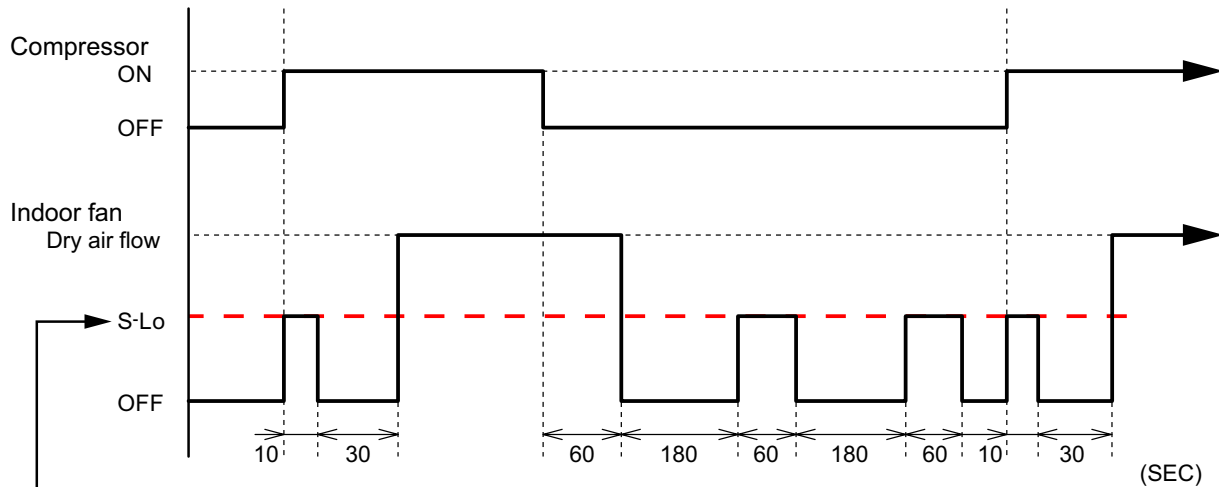

When an IAQ works in 9/12LA models, it operate with S-LO without stopping.

4. AUTO CHANGEOVER OPERATION

When the air conditioner is set to the AUTO mode by remote control, operation starts in the optimum mode from among the HEATING, COOLING, DRY and MONITORING modes. During operation, the optimum mode is automatically switched in accordance with temperature changes. The temperature can be set between 64°F(18°C) and 88°F(30°C) in 2°F(1°C) steps.

- ①. When operation starts, only the indoor and outdoor fans are operated for 1 minute. After 1 minute, the room temperature and outside air temperature are sensed and the operation mode is selected in accordance with the table below.

(Fig.5 : Outside air temperature zone selection)

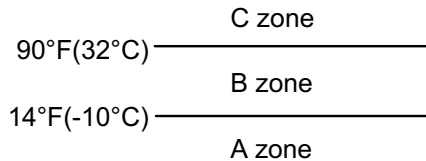

(Table.4 Operation mode selection table)

Outside air temperature (TO) Room temperature(TB)	A zone	B zone	C zone
$TB > TS + 4^{\circ}\text{F}(2^{\circ}\text{C})$	Monitoring	Cooling (automatic dry)	Cooling (automatic dry)
$TS + 4^{\circ}\text{F}(2^{\circ}\text{C}) \geq TB \geq TS - 4^{\circ}\text{F}(2^{\circ}\text{C})$	Monitoring	Monitoring	Monitoring
$TB < TS - 4^{\circ}\text{F}(2^{\circ}\text{C})$	*Heating	*Heating	Monitoring

*18CL is Monitoring

- ②. When COOLING was selected at ①, the air conditioner operates as follow:
- The same operation as COOLING OPERATION of item 1 above is performed.
 - When the room temperature has remained at (set temperature -2°F(1°C)) for 8 minutes, operation is automatically switched to DRY and the same operation as DRY OPERATION of item 3 above is performed.
 - If the room temperature reaches (set temperature +4°F(2°C)) during DRY operation, operation returns to COOLING operation.
- ③. When HEATING was selected at ①, the same operation as HEATING OPERATION of item 2 above is performed.
- ④. When the compressor was stopped for 6 consecutive minutes by the temperature control function after the COOLING or HEATING operation mode was selected at ① above, operation is switched to MONITORING and the operation mode is selected again.

5. INDOOR FAN CONTROL

(1).Fan speed

(Table 5 : Indoor Fan Speed)

ASU9RLQ			ASU12RLQ		
Operation mode	Air flow mode	Speed (rpm)	Operation mode	Air flow mode	Speed (rpm)
Heating	Hi	1390	Heating	Hi	1440
	Me+	1350		Me+	1350
	Me	1200		Me	1200
	Lo	1000		Lo	1000
	Quiet	760		Quiet	760
	Cool air prevention	760		Cool air prevention	760
	S-Lo	480		S-Lo	480
Cooling Fan	Hi	1300	Cooling Fan	Hi	1370
	Me	1120		Me	1150
	Lo	950		Lo	950
	Quiet	700		Quiet	700
Dry		700	Dry		700

ASU18CL			ASU18RL		
Operation mode	Air flow mode	Speed (rpm)	Operation mode	Air flow mode	Speed (rpm)
Heating	Hi	-	Heating	Hi	1480
	Me+	-		Me+	1420
	Me	-		Me	1300
	Lo	-		Lo	1110
	Quiet	-		Quiet	950
	Cool air prevention	-		Cool air prevention	850
	S-Lo	480		S-Lo	480
Cooling Fan	Hi	1480	Cooling Fan	Hi	1480
	Me	1260		Me	1260
	Lo	1040		Lo	1040
	Quiet	850		Quiet	850
Dry		850	Dry		850

(2).FAN OPERATION

The airflow can be switched in 5 steps such as AUTO, QUIET, LOW, MED, HIGH, while the indoor fan only runs.

When Fan mode is set at (Auto), it operates on (MED) Fan Speed.

(3).COOLING OPERATION

Switch the airflow [AUTO], and the indoor fan motor will run according to a room temperature, as shown in Figure 6.

On the other hand, if switched in [HIGH] ~ [QUIET], the indoor motor will run at a constant airflow of [COOL] operation modes QUIET, LOW, MED, HIGH, as shown in Table 5.

(Fig.6)

airflow change - over (Cooling:AUTO)

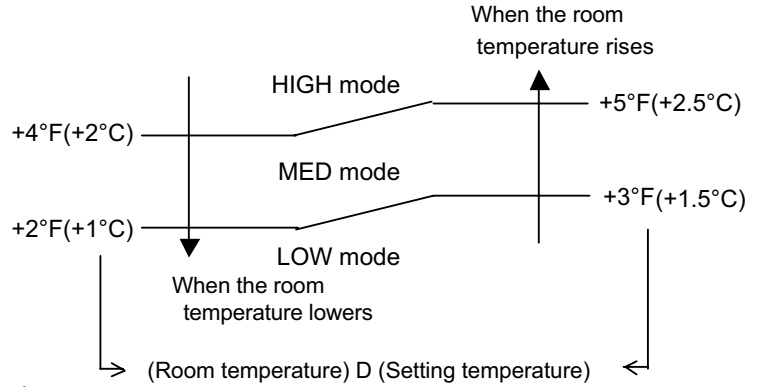

(4).DRY OPERATION

Refer to the table 4.

Durring the dry mode operation, the fan speed setting can not be changed.

(5).HEATING OPERATION

Switch the airflow [AUTO], and the indoor fan motor will run according to a room temperature, as shown in Figure 7.

On the other hand, if switched [HIGH] ~ [QUIET], the indoor motor will run at a constant airflow of [HEAT] operation modes QUIET, LOW, MED, HIGH, as shown in Table 5.

(Fig.7)

airflow change - over (Heating:AUTO)

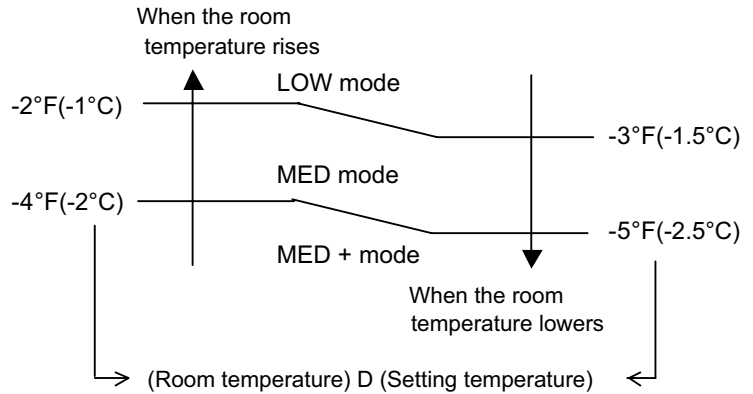

(6).COOL AIR PREVENTION CONTROL (Heating mode)

The maximum value of the indoor fan speed is set as shown in Figure 8, based on the detected temperature by the indoor heat exchanger sensor on heating mode.

(Fig.8 : Cool Air Prevention Control)

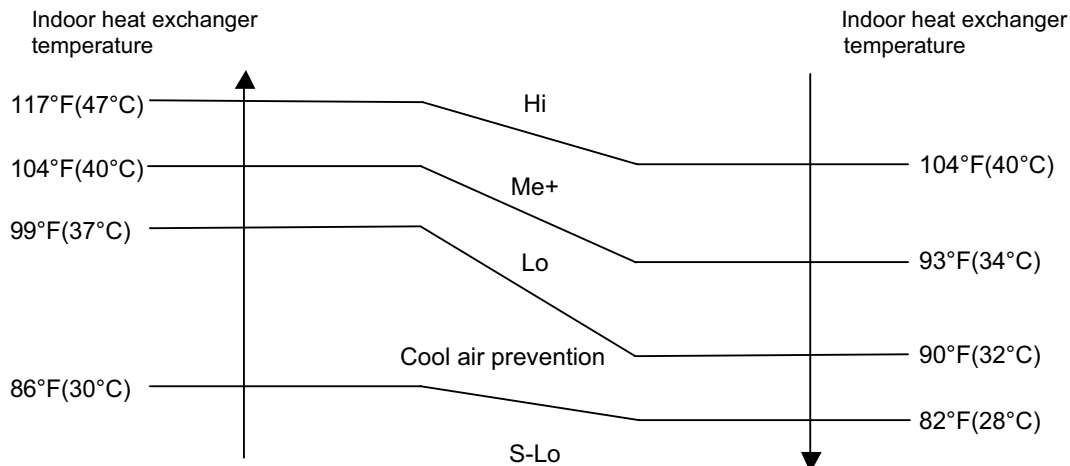

6. OUTDOOR FAN CONTROL

(1). Fan Speed

(Table 6 : Outdoor fan speed)

(rpm)

	ZONE※	Cooling	Dry	Heating
ASU9RLQ	A-D	800/760/470	500	760/680/470
	E	400/280	400/280	
	F	200	200	
ASU12RLQ	A-D	800/760/470	500	760/680/470
	E	400/280	400/280	
	F	250/200	250/200	
ASU18CL	A-D	860/820/670/500	500	-
	E	400/340/280	400/340/280	
	F	280/250/230	280/250/230	
ASU18RL	A-D	860/820/670/500	500	820/750/670/450
	E	400/340/280	400/340/280	
	F	280/250/230	280/250/230	

※ Refer to Fig1.

(1). Fan Speed

- * It runs at 500(A-D ZONE)/200(E,F ZONE) rpm for 20 seconds after starting up the outdoor fan.
- * The outdoor fan speed mentioned above depends on the compressor frequency.
(When the compressor frequency increases, the outdoor fan speed also changes to the higher speed. When the compressor frequency decreases, the outdoor fan speed also changes to the lower speed.)
- * Outdoor temperature falls, and if it becomes E and F zone(Refer to Fig1), rotations of fan speed will fall.
- * After the defrost control is operated on the heating mode, the fan speed keeps at the higher speed as table 7 without relating to the compressor frequency.

(Table 7 : Outdoor fan speed after the defrost)

	Min
ASU9RLQ	800rpm
ASU12RLQ	900rpm
ASU18CL	-
ASU18RL	950rpm

7. LOUVER CONTROL

(1). VERTICAL LOUVER CONTROL

(Function Range)

Each time the button is pressed, the air direction range will change as follow:

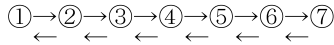

(Fig 9: Air Direction Range)

(Operation Range)

Cooling / Dry mode : ①-②-③
 Heating mode : ④-⑤-⑥-⑦
 Fan mode : ①-②-③-④-⑤-⑥-⑦

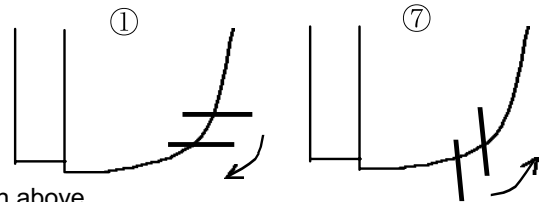

Use the air direction adjustments within the ranges shown above.

- The vertical airflow direction is set automatically as shown, in accordance with the type of operation selected.
 - Cooling / Dry mode : Horizontal flow ①
 - Heating mode : Downward flow ⑦
- When the temperature of the air being blown out is low at the start of heating operation or during defrosting, the airflow direction temporarily becomes ⑦ to prevent cold air being blown onto the body.
- During use of the Cooling and Dry modes, do not set the Air Flow Direction Louver in the Heating range (④~⑦) for long period of time, since water vapor may condense near the outlet louvers and drop of water may drip from the air conditioner. During the Cooling and Dry modes, if the Air Flow Direction Louvers are left in the heating range for more than 30minutes, they will automatically return to position ③.
- During Monitor operation in AUTO CHANGEOVER mode, the airflow direction automatically becomes ①, and it cannot be adjusted.

(2). SWING OPERATION

When the swing signal is received from the remote controller, the vertical louver starts to swing.

(Swinging Range)

Cooling mode / Dry mode / Fan mode(①~③) : ① ⇔ ③
 Heating mode / Fan mode(④~⑦) : ③ ⇔ ⑦

- When the indoor fan is either at S-lo or Stop mode, the swinging operation is interrupted and the louver stops at the memorized position.

8. COMPRESSOR CONTROL

(1). OPEARTION FREQUENCY RANGE

The operation frequency of the compressor is different based on the operation mode as shown in the table 8.

(Table 8 : Compressor Operation Frequency Range)

	Cooling		Heating		Dry
	Min	Max	Min	Max	
ASU9RLQ	18Hz	80Hz	18Hz	130Hz	33Hz
ASU12RLQ	18Hz	96Hz	18Hz	130Hz	33Hz
ASU18CL	18Hz	90Hz	-	-	24Hz
ASU18RL	18Hz	90Hz	18Hz	119Hz	24Hz

(2). OPEARTION FREQUENCY CONTROL AT START UP

The compressor frequency soon after the start-up is controlled as shown in the figure 10.

(Fig.10 : Compressor Control at Start-up)

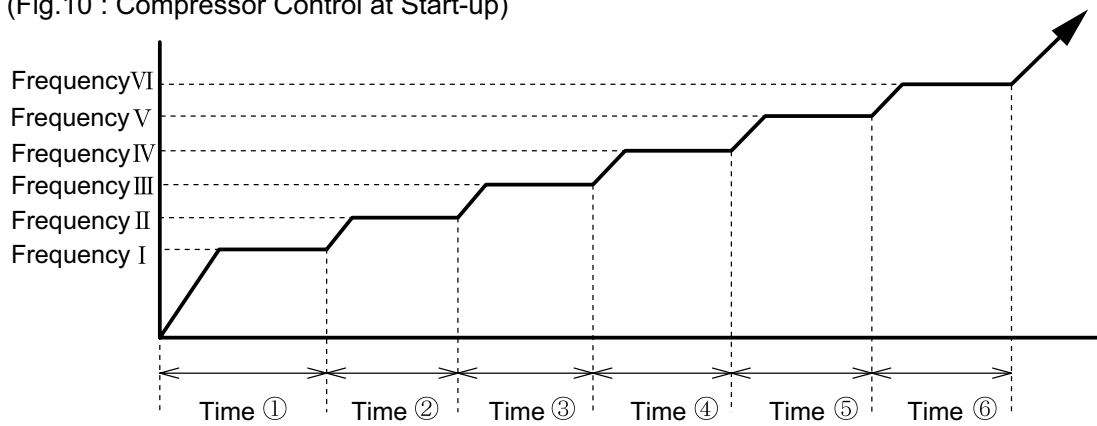

(Frequency)

	Frequency I	Frequency II	Frequency III	Frequency IV	Frequency V	Frequency VI
ASU9RLQ	56Hz	74Hz	87Hz	97Hz	108Hz	119Hz
ASU12RLQ	56Hz	74Hz	87Hz	97Hz	108Hz	119Hz
ASU18CL	40Hz	59Hz	72Hz	80Hz	101Hz	110Hz
ASU18RL	40Hz	59Hz	72Hz	80Hz	101Hz	110Hz

(Time)

	Time ①	Time ②	Time ③	Time ④	Time ⑤	Time ⑥
ASU9RLQ	80sec	60sec	60sec	180sec	60sec	60sec
ASU12RLQ	80sec	60sec	60sec	180sec	60sec	60sec
ASU18CL	60sec	40sec	40sec	60sec	150sec	60sec
ASU18RL	60sec	40sec	40sec	60sec	150sec	60sec

9. TIMER OPERATION CONTROL

The table 9 shows the available timer setting based on the product model.

(Table 9 : Timer Setting)

	ON TIMER / OFF TIMER	PROGRAM TIMER	SLEEP TIMER
ASU9RLQ	○	○	○
ASU12RLQ	○	○	○
ASU18CL	○	○	○
ASU18RL	○	○	○

(1). OPERATION FREQUENCY RANGE

- OFF timer : When the clock reaches the set time, the air conditioner will be turned off.

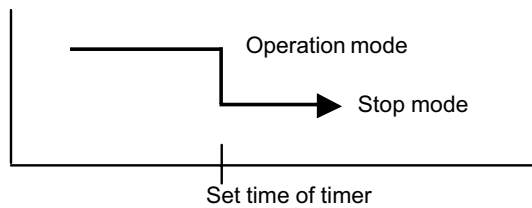

- ON timer : When the clock reaches the set time, the air conditioner will be turned on.

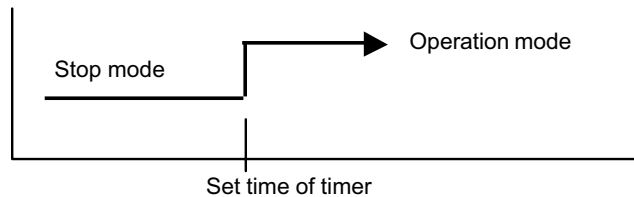

(2). PROGRAM TIMER

- The program timer allows the OFF timer and ON timer to be used in combination one time.

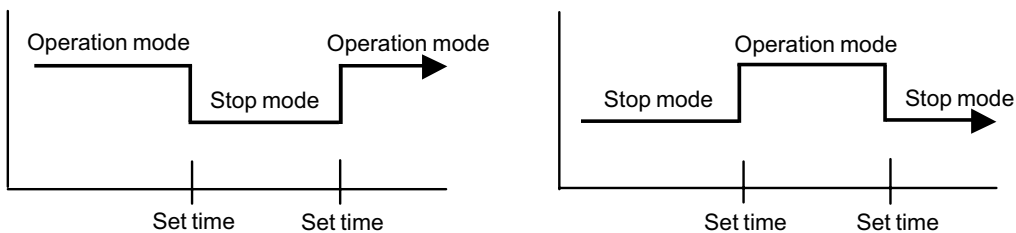

- Operation will start from the timer setting (either OFF timer or ON timer) whichever is closest to the clock's current timer setting. The order of operations is indicated by the arrow in the remote control unit's display.
- SLEEP timer operation cannot be combined with ON timer operation.

(3). SLEEP TIMER

If the sleep is set, the room temperature is monitored and the operation is stopped automatically. If the operation mode or the set temperature is change after the sleep timer is set, the operation is continued according to the changed setting of the sleep timer from that time ON.

In the cooling operation mode

When the sleep timer is set, the setting temperature is increased $2^{\circ}\text{F}(1^{\circ}\text{C})$. It increases the setting temperature another $2^{\circ}\text{F}(1^{\circ}\text{C})$ after 1 hour. After that, the setting temperature is not changed and the operation is stopped at the time of timer setting.

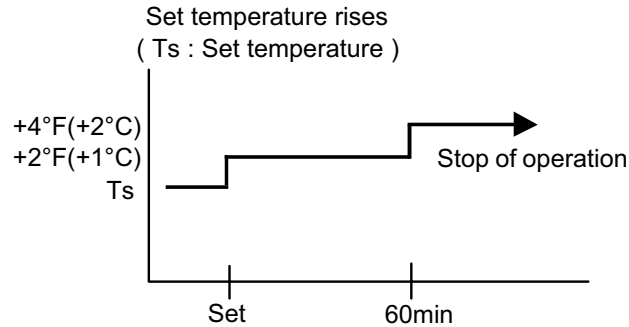

In the heating operation mode

When the sleep timer is set, the setting temperature is decreased $2^{\circ}\text{F}(1^{\circ}\text{C})$. It decreases the setting temperature another $2^{\circ}\text{F}(1^{\circ}\text{C})$ every 30 minutes. Upon lowering $8^{\circ}\text{F}(4^{\circ}\text{C})$, the setting temperature is not changed and the operation stops at the time of timer setting.

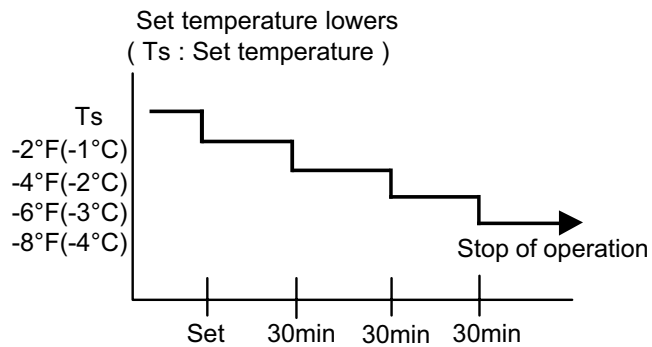

10. ELECTRONIC EXPANSION VALVE CONTROL

The most proper opening of the electronic expansion valve is calculated and controlled under the present operating condition based on the following values.

The compressor frequency, the temperatures detected by the discharge temperature sensor, the indoor heat exchanger sensor, the outdoor heat exchanger sensor, and the outdoor temperature sensor.

- * The pulse range of the electronic expansion valve control is between 60 to 480 pulses.
- * The expansion valve is set at 480 pulses after 110 seconds of stopping compressor.
- * At the time of supplying the power to the outdoor unit, the initialization of the electronic expansion valve is operated (528 pulses are input to the closing direction).

11. TEST OPERATION CONTROL

Under the condition where the air conditioner runs, press the test operation button of the remote control, and the test operation control mode will appear. During test running, the operation lamp and timer lamp of the air conditioner body twinkle simultaneously. Set the test operation mode, and the compressor will continue to run regardless of whether the room temperature sensor detects. The test operation mode is released if 60 minutes have passed after setting up the test operation.

12. PREVENT TO RESTART FOR 3 MINUTES (3 MINUTES ST)

The compressor won't enter operation status for 2 minutes and 20 seconds after the compressor is stopped, even if any operation is given.

13. FOUR-WAY VALVE EXTENSION SELECT

At the time when the air conditioner is switched from the cooling mode to heating mode, the compressor is stopped, and the four-way valve is switched in 2 minutes and 20 seconds later after the compressor stopped.

14. AUTO RESTART

When the power was interrupted by a power failure, etc. during operation, the operation contents at that time are memorized and when power is recovered, operation is automatically started with the memorized operation contents.

When the power is interrupted and recovered during timer operation, since the timer operation time is shifted by the time the power was interrupted, an alarm is given by blinking (7 sec ON/2 sec OFF) the indoor unit body timer lamp.

[Operation contents memorized when the power is interrupted]

- Operation mode
- Set temperature
- Set air flow
- Timer mode and timer time
- Set air flow Direction
- Swing
- Air clean(Only 9/12LA model)

15. MANUAL AUTO OPERATION (Indoor unit body operation)

If MANUAL AUTO Button is set, the operation is controlled as shown in Table 10.
If the remote control is lost or battery power dissipated, this function will work without the remote control.

(Table 10)

	Manual auto operation	Forced cooling operation
OPERATION MODE	Auto changeover	Cooling
FAN CONT. MODE	Auto	Hi
TIMER MODE	Continuous (No timer setting available)	-
SETTING TEMP.	75°F(24°C)	Room Temp is not controlled
SETTING LOUVER	Standard	Horizontal
SWING	OFF	OFF

16. FORCED COOLING OPERATION

Forced cooling operation is started when pressing MANUAL AUTO button for 10 seconds or more. During the forced cooling operation, it operates regardless of room temperature sensor. Operation LED and timer LED blink during the forced cooling operation. They blink for 1 second ON and 1 second OFF on both operation LED and timer LED (same as test operation). Forced cooling operation is released after 60 minutes of starting operation. The FORCED COOLING OPERATION will start as shown in Table 10.

17. COMPRESSOR PREHEATING

When the outdoor heat exchanger temperature is lower than temperature and the heating operation has been stopped for 30 minutes, power is applied to the compressor and the compressor is heated. (By heating the compressor, warm air is quickly discharged when operation is started.) When operation was started, and when the outdoor temperature rises to temperature or greater, preheating is ended.

(Table 11 : Preheating Operation / Release Temperature)

	Temperature I	Temperature II
ASU9RLQ	41°F(5°C)	45°F(7°C)
ASU12RLQ	41°F(5°C)	45°F(7°C)
ASU18CL	-	-
ASU18RL	41°F(5°C)	45°F(7°C)

18. COIL DRY OR AIR CLEAN OPERATION CONTROL

(1). COIL DRY OPERATION CONTROL (ASU18RL model only)

The coil-dry operation functions by pressing COIL DRY button on the remote controller. The coil-dry operation is consisted of 3 cycles of [Fan operation 3 minutes / Heating operation 2 minutes], and Fan operates for 3 minutes at last before ending the air conditioner operation. (It takes 18 minutes to complete the coil-dry operation.)

(2). AIR CLEAN OPERATION CONTROL (ASU9/12RLQ model only)

The coil-dry operation functions by pressing AIR CLEAN button on the remote controller. It continues from COIL DRY operation, it turns on electricity to AIR CLEAN UNIT, sterilization is performed for 15 minutes. Indoor unit fan motor operation under AIR CLEAN operation : The cycle of 480rpm Fixation 5 sec ON / 1 min OFF is repeated. (It takes 33 minutes to complete the AIR CLEANING operation.)

(Table 12 : COIL-DRY or AIR-CLEAN Operating Functions)

	Indoor Fan Speed		Compressor Frequency	Louver Position	Main Unit Indication
ASU9RLQ	900rpm	480rpm	36Hz	①	COIL-DRY or AIR-CLEAN indication : ON Other indication : OFF
ASU12RLQ	900rpm	480rpm	36Hz	①	
ASU18RL	900rpm	-	34Hz	①	

19. DEFROST OPERATION CONTROL

(1). CONDITION OF STARTING THE DEFROST OPERATION

The defrost operation starts when the outdoor heat exchanger temperature sensor detects the temperature lower than the values shown in Table 13.

(Table 13 : Condition of starting Defrost Operation)

1 ST time defrosting after starting operation		Compressor operating time			
		Less than 20 minutes	20 to 60 minutes	60 minutes to 4 hours	After 4 hours
	ASU9RLQ	Does not operate	- 16°F(-9°C)	- 23°F(-5°C)	- 27°F(-3°C)
	ASU12RLQ		- 16°F(-9°C)	- 23°F(-5°C)	- 27°F(-3°C)
	ASU18CL		-	-	-
	ASU18RL		- 16°F(-9°C)	- 23°F(-5°C)	- 27°F(-3°C)
Defrosting after 2 nd time upon starting operation		Compressor operating time			
		Less than 35 minutes	35 minutes to 4 hours	X	After 4 hours
	ASU9RLQ	Does not operate	- 21°F(-6°C)		- 27°F(-3°C)
	ASU12RLQ		- 21°F(-6°C)		- 27°F(-3°C)
	ASU18CL		-		-
	ASU18RL		- 21°F(-6°C)		- 27°F(-3°C)

(2). CONDITION OF THE DEFROST OPERATION COMPLETION

Defrost operation is released when the conditions become as shown in Table 14.

(Table 14 : Defrost Release Condition)

	Release Condition
ASU9RLQ	Outdoor heat exchanger temperature sensor value is higher than 61°F(16°C) or Compressor operation time has passed 15 minutes.
ASU12RLQ	Outdoor heat exchanger temperature sensor value is higher than 61°F(16°C) or Compressor operation time has passed 15 minutes.
ASU18RL	Outdoor heat exchanger temperature sensor value is higher than 50°F(10°C) or Compressor operation time has passed 15 minutes.

Defrost Flow Chart

The defrosting shall proceed by the integrating operation time and outdoor heat exchanger temperature as follows.

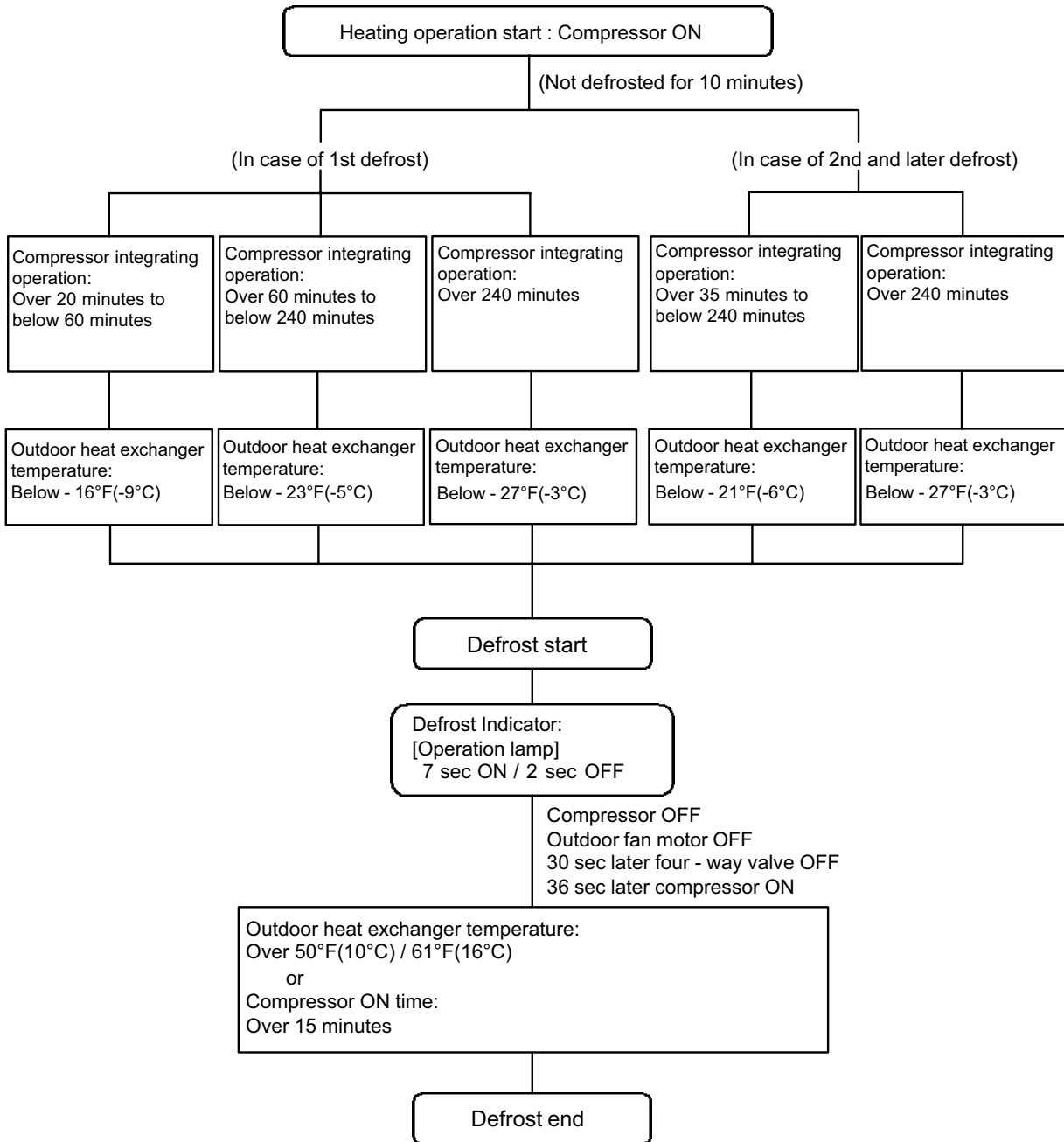

20. OFF DEFROST OPEARTION CONTROL

When operation stops in the [Heating operation] mode, if frost is adhered to the outdoor unit heat exchanger, the defrost operation will proceed automatically. In this time, if indoor unit operation lamp flashes slowly (7 sec ON / 2 sec OFF), the outdoor unit will allow the heat exchanger to defrost, and then stop.

(1). OFF DEFROST OPERATION CONDITION

In heating operation, the outdoor heat exchanger temperature is less than - 25°F(-4°C), and compressor operation integrating time lasts for more than 30 minutes.

(2). OFF DEFROST END CONDITION

	Release Condition
ASU9RLQ	Outdoor heat exchanger temperature sensor value is higher than 61°F(16°C) or Compressor operation time has passed 15 minutes.
ASU12RLQ	Outdoor heat exchanger temperature sensor value is higher than 61°F(16°C) or Compressor operation time has passed 15 minutes.
ASU18RL	Outdoor heat exchanger temperature sensor value is higher than 50°F(10°C) or Compressor operation time has passed 15 minutes.

OFF Defrost Flow Chart

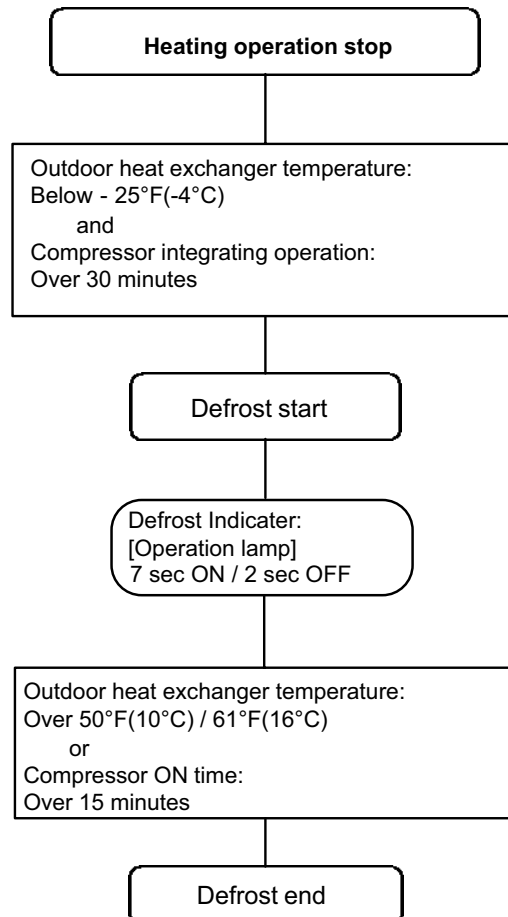

21. VARIOUS PROTECTIONS

(1). DISCHARGE GAS TEMPERATURE OVERRISE PREVENION CONTROL

The discharge gas thermosensor (discharge thermistor : Outdoor side) will detect discharge gas temperature.

When the discharge temperature becomes higher than Temperature I ,the compressor frequency is decreased 20 Hz, and it continues to decrease the frequency for 20 Hz every 120 seconds until the temperature becomes lower than Temperature I.

When the discharge temperature becomes lower than Temperature II,the control of the control of the compressor frequency is released.

When the discharge temperature becomes higher than Temperature III ,the compressor is stopped and the indoor unit LED starts blinking.

(Table 15 : Discharge Temperature Over Rise Prevension Control / Release Temperature)

	Temperature I	Temperature II	Temperature III
ASU9RLQ	219°F(104°C)	214°F(101°C)	230°F(110°C)
ASU12RLQ	219°F(104°C)	214°F(101°C)	230°F(110°C)
ASU18CL	219°F(104°C)	214°F(101°C)	230°F(110°C)
ASU18RL	219°F(104°C)	214°F(101°C)	230°F(110°C)

(2). CURRENT RELEASE CONTROL

The compressor frequency is controlled so that the outdoor unit input current does not exceeds the current limit value that was set up with the outdoor temperature.

The compressor frequency returns to the designated frequency of the indoor unit at the time when the frequency becomes lower than the release value.

(Table 16 : Current Release Operation Value / Release Value)

[Heating] OT : Outdoor Temperature

ASU9RLQ	ASU12RLQ	ASU18CL	ASU18RL
OT (Control / Release)	OT (Control / Release)	OT (Control / Release)	OT (Control / Release)
63°F(17°C) $\frac{6.5A / 6.0A}{8.0A / 7.5A}$	63°F(17°C) $\frac{6.5A / 6.0A}{8.0A / 7.5A}$	63°F(17°C) $\frac{/}{/}$	63°F(17°C) $\frac{7.0A / 6.5A}{9.0A / 8.5A}$
54°F(12°C) $\frac{8.0A / 7.5A}{8.0A / 7.5A}$	54°F(12°C) $\frac{8.5A / 8.0A}{8.5A / 8.0A}$	54°F(12°C) $\frac{/}{/}$	54°F(12°C) $\frac{10.5A / 10.0A}{10.5A / 10.0A}$
41°F(5°C) $\frac{8.0A / 7.5A}{8.0A / 7.5A}$	41°F(5°C) $\frac{9.5A / 9.0A}{9.5A / 9.0A}$	41°F(5°C) $\frac{/}{/}$	41°F(5°C) $\frac{12.0A / 11.5A}{12.0A / 11.5A}$

[Cooling / Dry] OT : Outdoor Temperature

ASU9RLQ	ASU12RLQ	ASU18CL	ASU18RL
OT (Control / Release)	OT (Control / Release)	OT (Control / Release)	OT (Control / Release)
115°F(46°C) $\frac{3.5A / 3.0A}{4.0A / 3.5A}$	115°F(46°C) $\frac{4.0A / 3.5A}{5.0A / 4.5A}$	115°F(46°C) $\frac{4.5A / 4.0A}{6.0A / 5.5A}$	115°F(46°C) $\frac{4.5A / 4.0A}{6.0A / 5.5A}$
104°F(40°C) $\frac{5.5A / 5.0A}{5.5A / 5.0A}$	104°F(40°C) $\frac{6.5A / 6.0A}{6.5A / 6.0A}$	104°F(40°C) $\frac{8.5A / 8.0A}{8.5A / 8.0A}$	104°F(40°C) $\frac{8.5A / 8.0A}{8.5A / 8.0A}$

(3). ANTIFREEZING CONTROL (Cooling and Dry mode)

The compressor frequency is decrease on cooling & dry mode when the indoor heat exchanger temperature sensor detects the temperature lower than Temperature I. Then, the anti-freezing control is released when it becomes higher than Temperature II.

(Table 17 : Anti-freezing Protection Operation / Release Temperature)

	Temperature I	Temperature II
A-D	39°F(4°C)	45°F(7°C)
E,F	39°F(4°C)	55°F(13°C)

(4). COOLING PRESSURE OVERRISE PROTECTION

When the outdoor unit heat exchange sensor temperature rises to temperature I or greater, the compressor is stopped and trouble display is performed.

(Table 18 : Cooling Pressure Over Rise Protection Function Temperature)

	Temperature I
ASU9RLQ	153°F(67°C)
ASU12RLQ	153°F(67°C)
ASU18CL	153°F(67°C)
ASU18RL	153°F(67°C)

(5). HIGH TEMPERATURE RELEASE CONTROL (HEATING MODE)

On heating mode, the compressor frequency is controlled as following based on the detection value of the indoor heat exchanger temperature sensor.

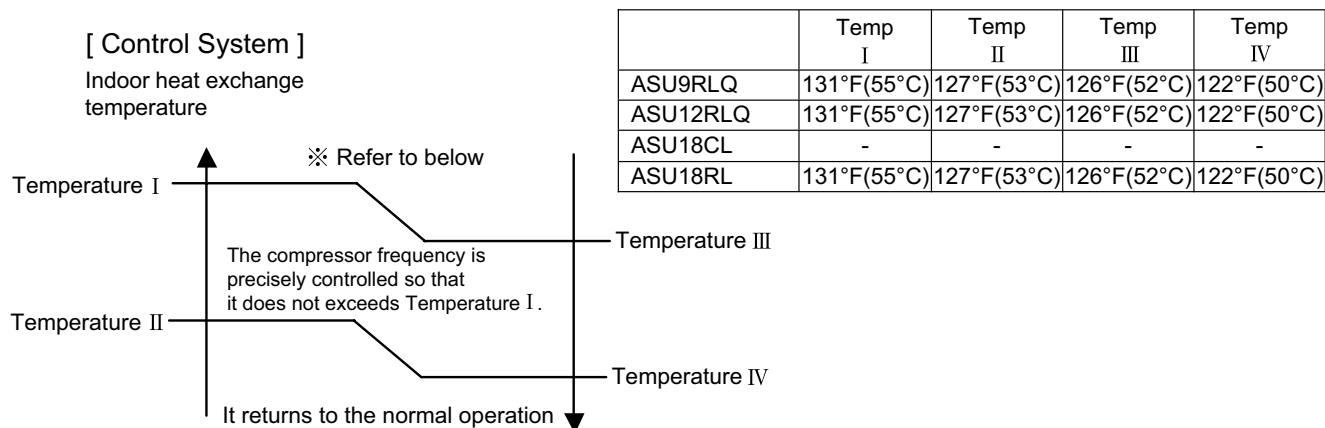

※ Compressor Operation

[ASU9/12RLQ]

- 46Hz or greater → 45Hz
- 39~45Hz → Frequency down every 120 seconds
- 26~38Hz → 25Hz
- 18~25Hz → OFF

[ASU18RL]

- 39Hz or greater → 38Hz
- 30~38Hz → Frequency down every 120 seconds
- 19~29Hz → 18Hz
- 18Hz → OFF

WALL MOUNTED type INVERTER

6 . REFRIGERANT CAUTION -R410A-

1. R410A TOOLS

This air conditioner used R410A.
For installation and servicing, it is necessary to prepare the tools and machines that are different from the previous refrigerant.

- ⊙ **Mark shows the exclusive use for R410A.**
- ⊙ **Gauge manifold** (Fig.4-1)
The specification of the gauge is different due to higher pressure.
The size of connection pipe is also different to prevent mis-use.
- ⊙ **Charge hose** (Fig.4-2)
Since the normal pressure is high, the connection pipe size is also different.
- ⊙ **Refrigerant cylinder** (Fig.4-3)
Confirm the refrigerant type before charging. Always charge liquid-phase refrigerant.
- Electronic balance for refrigerant charging** (Fig.4-4)
Electronic balance is recommended as in the case of R410A.
- ⊙ **Vacuum pump with adapter to prevent reverse flow**(Fig.4-5)
Conventional pump can be used.
- Vacuum holder** (Fig.4-6)
Conventional pump can be used if adapter for preventing vacuum pump oil from flowing back is used.
- ⊙ **Gas leakage tester** (Fig.4-7)
Exclusive for HFC
- Refrigerant cleaner** (Fig.4-8)
Brown paint as designated by the ARI, USA
- ⊙ **Flare tool** (Fig.4-9)
The shape of flare is different for high pressure condition.
- ⊙ **Torque wrench** (Fig.4-10)
- ⊙ **Refrigerant recovering equipment (Collector)** (Fig.4-11)
The type which can be used for any refrigerant is available
- Nitrogen cylinder** (Fig.4-12)
This prevents an oxide film from forming in the pipe silver-alloy brazing work by turning the air out of the pipe and preventing the inside combustion.
- ⊙ **Safety charger** (Fig.4-13)
It is always compulsory to change the liquid, because R410A is a mixed refrigerant and there is some fear that a mixing ratio changes. In order to avoid the refrigerant from returning to the compressor in a liquid state, the refrigerant can be charged instead of giving a load to the compressor with a safety charger.
- Control valve** (Fig.4-14)
The control valve prevents the refrigerant from spouting when it is removed, as the charging hose side and the service port side are possible to open and close at the same time.
- Thermistor vacuum gauge** (Fig.4-15)
To remove moisture from the refrigerating cycle completely, it is necessary to perform appropriate vacuum drying. For that reason, vacuum conditions can be confirmed certainly.
- Vacuum valve** (Fig.4-16)
This valve builds in a check valve, and it is easily possible to vacuum a refrigerating cycle or check for degree of vacuum with it.

TOOLS AND EQUIPMENT (R410A)

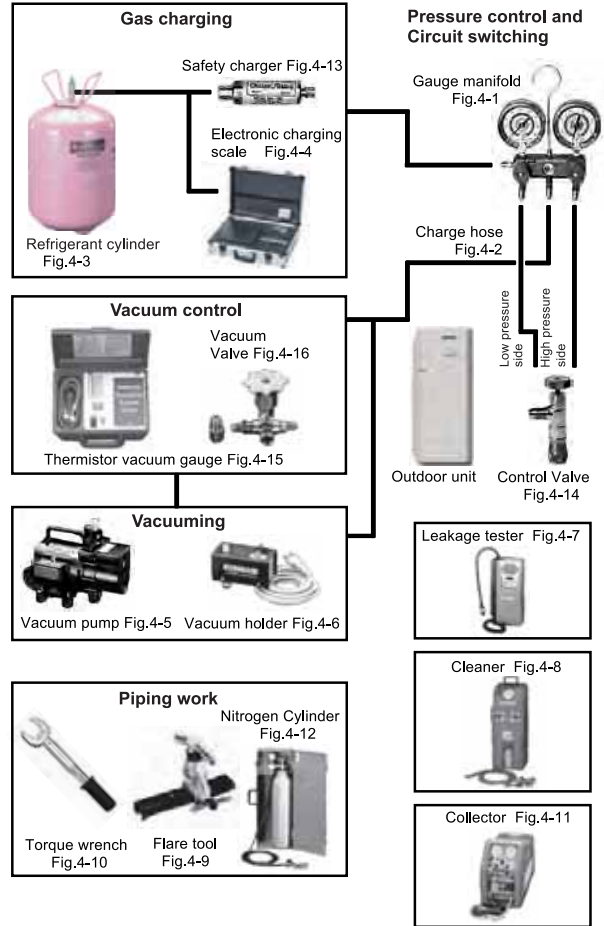

* 1 Gauge Manifold

	R410A	R22, R407C
High pressure gauge	-0.1~5.3 Mpa	-0.1~3.5 Mpa
Compound gauge	-0.1~3.8 Mpa	-0.1~1.7 Mpa
Port size	1/2UNF 5/16"	7/16UNF 1/4"

* 2 Charge hose

	R410A	R22, R407C
Normal pressure	5.1 Mpa	3.4 Mpa
Breaking pressure	27.4 Mpa	17.2 Mpa
Port size	1/2UNF	7/16UNF

2. PRECAUTION FOR INSTALLATION

Precaution for installation

Pipe diameter, recommended material and wall thickness

Nominal diameter (in)	1/4"	3/8"	1/2"	5/8"	3/4"	7/8"	1"	1 1/8"	1 1/4"	1 3/8"	1 1/2"
Outside diameter (mm)	6.35	9.52	12.70	15.88	19.05	22.22	25.40	28.58	31.75	34.92	38.10
Material	COPPER JIS H3300-C1220T-O or equivalent ¹⁾					COPPER JIS H3300-C1220T-H or equivalent ²⁾					
Wall thickness ³⁾ (mm)	0.8	0.8	0.8	1.0	1.2	1.0	1.0	1.0	1.1	1.2	1.3

1) Allowable tensile stress ≥ 33 (N/mm²); 2) Allowable tensile stress ≥ 61 (N/mm²); 3) Design pressure 4.2MPa.

The pipe must be properly pressure rated for R410A
The pipe must be an air-conditioning refrigerant pipe.

Flare and flare nuts

Diameter	1/4" (6.35mm)		3/8" (9.52mm)		1/2" (12.7mm)		3/8" (15.88mm)		3/4" (19.05mm)	
Refrigerant	R410A	R22 /R407C	R410A	R22 /R407C	R410A	R22 /R407C	R410A	R22 /R407C	R410A	R22 /R407C
A	9.1	9.0	13.2	13.0	16.6	16.2	19.7	19.4	24	23.7
B	13	12	20	15	13	20	25	23	29	29
C	12	11	16	12.5	19	16	22	20	24	24
Nut width	17		22		26	24	29	27	36	

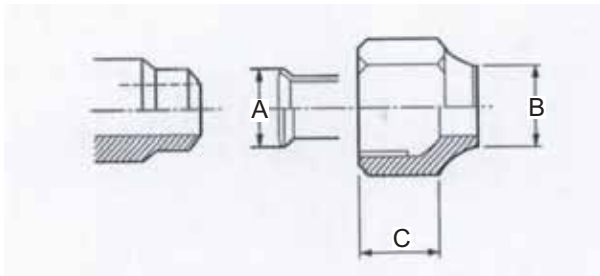

Always use the flare nut that is packed with the product.

Do not use existing (for R22) pipes

- Be sure to use new pipes when replacing conventional (R22) model with HFC (R407C, R410A) model.
- If you use existing pipes, it may cause resolution of compressor oil by remaining mineral oil.

Be careful not to mix moisture and contamination into the pipe

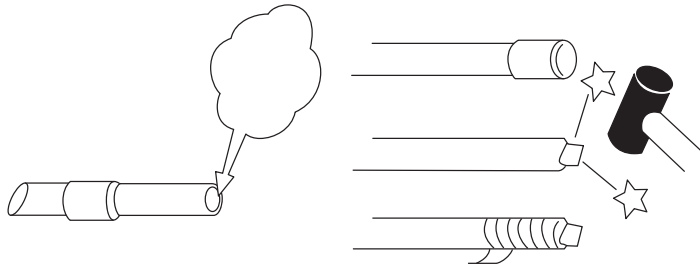

Moisture and contamination in the pipe is a cause of trouble.

Air purge

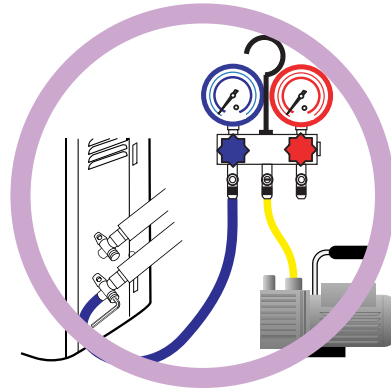
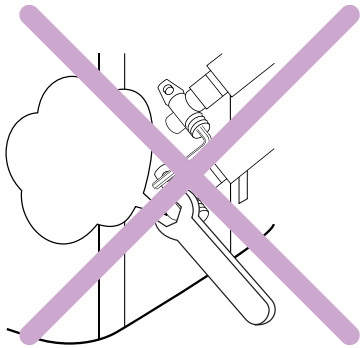

Always use a vacuum pump to purge air.

Refrigerant charge

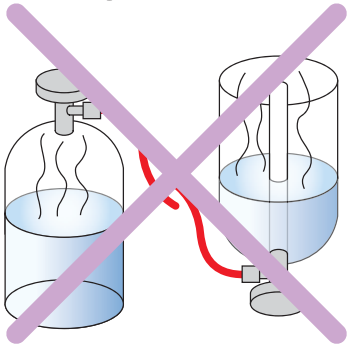

Don't charge from the gas phase side.

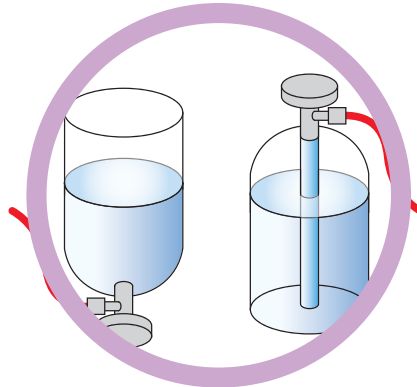

Do it always from the liquid phase side.

Compressor oil is changed

- We developed new synthetic oil, since HFC refrigerant doesn't dissolve in mineral (for R22) oil.
- Be careful to handle synthetic oil, since it resolves easily by moisture and contamination.
- Don't mix new synthetic oil and mineral oil. It may cause trouble.

3. PRECAUTION FOR SERVICING

Feature 1 Refrigerant oil is different from before.

Refrigerant oil for
New Refrigerant

Synthetic oil

Ether

Esther

※ Previously it was
mineral oil.

Different point from
previous one

- Absorbent character is high.
- Contamination occurs when mixed with other kind of oil.

Precaution on Tools

- Use the gauge manifold and charge hose for New Refrigerant(HFC), which shall be segregated from those of R22.
- Attach the stop valve on the vacuum pump and avoid the oil from reverse flow.
- It is necessary to use the vacuum pump which can obtain the high vacuum condition.

R410A

R22

Feature 2 New Refrigerant has Approx 1.6 times higher pressure than previous refrigerant.

R410A

High Pressure

※ 1.6 times of R22.

Different point from
previous one

- Diameter of Service port has been changed from 1/4 Flare to 5/16 Flare.
- JIS standard of flare process It became larger
- To keep the thickness of copper tube.
(1/4,3/3=more than 0.8mm)

Precaution on Tools

- It requires the gauge manifold and charge hose exclusively for R410A.
 - It requires the flare tool and torque wrench that satisfies New JIS standard.
- ※ Previous flare tool + flare adapter can be used as well.

4. NEW REFRIGERANT R410A

* What is HFC ?

Phase-out schedule of HCFC according to Montreal protocol

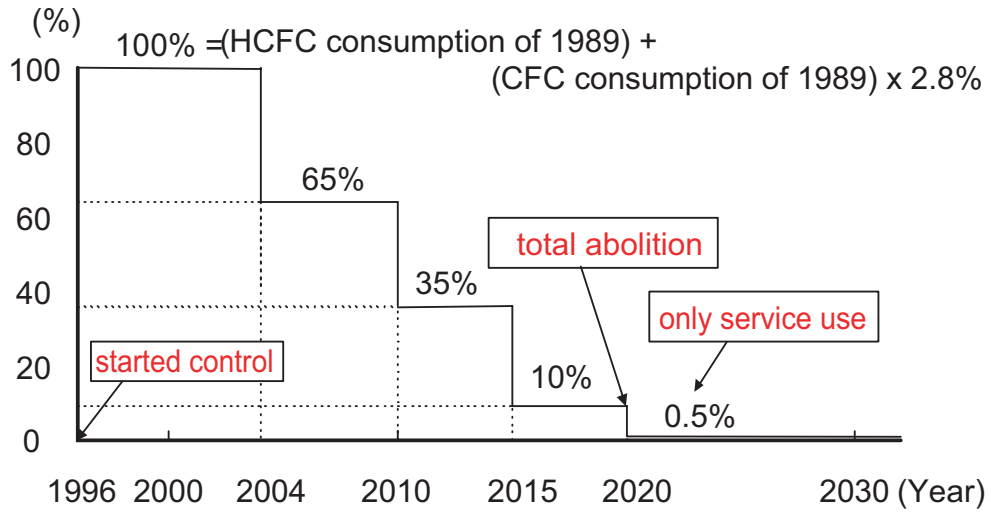

Ozone Layer depleting mechanism

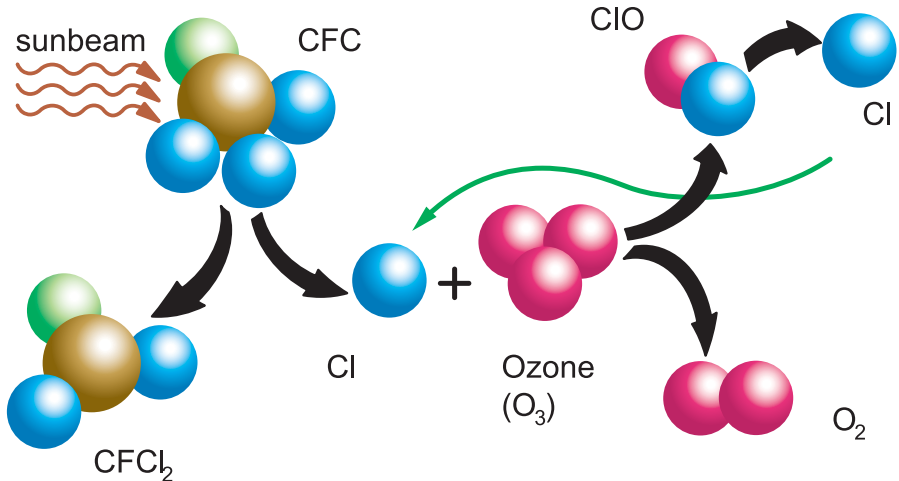

What is CFC and HCFC?

CFC : Chloro-Fluoro-Carbon

High ODP(ozone depletion potential) chemical compound, including chlorine. (ODP:0.6-1.0)
 For example : R12 (for refrigerator and car air-conditioner)

HCFC : Hydro-Chloro-Fluoro-Carbon

Low ODP chemical compound, including chlorine and hydrogen. (ODP:0.02-01)
 For example : R22 (for air-conditioner)

HFC₃ : Hydro-Fluoro-Carbon

R134a (for Car air conditioner)
 R407C (for air conditioner)

Refrigerant characteristics

	R410A	R407C	R22
Composition (wt%)	R32/R125 (50/50)	R32/R125/R134a (23/25/52)	R22 (100)
Boiling Point	- 51.4	- 43.6	- 40.8
Behavior	near azeotrope	zeotrope	---
Pressure at 54.5 °C (kPa)	3,406	2,262	2,151
Temperature Glide (deg)	0.11	5.4	0
ODP	0	0	0.055

Summary of R407C and R410A characteristics

	R410A	R407C
Advantage	<ul style="list-style-type: none"> • higher system performance • Near-Azeotropic refrigerant 	<ul style="list-style-type: none"> • similar pressure as R22 (possible to design large equipment)
Disadvantage	<ul style="list-style-type: none"> • 1.6 times higher pressure than R22 (difficult to design against pressure resistance) 	<ul style="list-style-type: none"> • Zeotropic refrigerant (handle with care)
Suitable for	<ul style="list-style-type: none"> • Small Air-Conditioners 	<ul style="list-style-type: none"> • Large Air-Conditioners

* Designed pressure of R410A refrigerant

Relation between R410A condensing temperature and saturated pressure.

< Pressure → Temp >

Pressure (Mpa)	Temp (°C)
2.20	37.9
2.25	38.7
2.30	39.6
2.35	40.5
2.40	41.3
2.45	42.1
2.55	43.8
2.60	44.6
2.65	45.3
2.70	46.1
2.75	46.8
2.80	47.6
2.85	48.3
2.90	49.0
2.95	49.8
3.00	50.5
3.05	51.2
3.10	51.9
3.15	52.6
3.20	53.2
3.25	53.9
3.30	54.6
3.35	55.3
3.40	55.9
3.45	56.5
3.50	57.1
2.55	57.8
3.60	58.4
3.65	59.0
3.70	59.6
3.75	60.2
3.80	60.8
3.85	61.4
3.90	52.0
3.95	62.5
4.00	63.1
4.05	63.6
4.10	64.2
4.15	64.8

< Temp → Pressure >

Temp (°C)	Pressure (Mpa)
39	2.27
40	2.32
41	2.38
42	2.44
44	2.57
45	2.63
46	2.69
47	2.76
48	2.83
49	2.90
51	3.04
52	3.11
53	3.18
54	3.26
56	3.41
57	3.49
58	3.57
59	3.65
61	3.82
62	3.90
63	3.99
64	4.08

5. DIFFERENCE FROM CONVENTIONAL MODEL (R22) AND PRECAUTIONS

OIL

- Use new synthetic oils such as ester because HFC series refrigerant has less solubility with mineral oils conventionally used for R22.
- As these new synthetic oils are easily influenced by moisture and dusts, they must be treated more carefully than the conventional lubricating oils.

CAUTION

For installation/servicing, take more precautions than the case of conventional refrigerants to avoid moisture and dusts entering the refrigerant circuit. Also, for storing parts, more precautions must be taken.

COMPRESSOR

- Use better grade of material for sliding parts for securing good lubrication of sliding part as HFC refrigerant does not contain chloride.
- Review insulating materials
- Increase pressure resistance strength

CAUTION

Check if the compressor is suitable for the refrigerant (model) when replacing. Complete welding within 15 minutes after opening the cap when replacing.

HEAT EXCHANGER

- Review the water, contaminants controlling level
- Use thinner tube to increase pressure Increase capacity for resistance strength (only outdoor unit) improving performance

CAUTION

During storage, due care must be taken so that foreign matters such as dust and water do not enter.

4-WAY VALVE

- Review materials

CAUTION

Check if the valve is suitable for the refrigerant (model) when replacing.

2, 3-WAY VALVE

- Review material O-ring, valve core seal for securing suitability with oil.

CAUTION

Check if the valve is suitable for the refrigerant (model) when replacing.

WALL MOUNTED type INVERTER

7 . TROUBLE SHOOTING

1. When the unit does not operate at all (Operation lamp and Timer lamp do not light up)
2. Self Diagnosis Function (Either Operation lamp or Timer lamp is blinking)
 - * How to operate the self-diagnosis function
 - * Self- diagnosis table and Check points
3. Trouble shooting method
 - * Serial signal check
 - * IPM protection check
 - * Refrigeration cycle diagnosis

Does not operate at all (Operation Lamp and Timer Lamp do not light up)

[Check Point]

- (1) Is the input power voltage from the exclusive circuit AC outlet normal?
- (2) Is the AC plug inserted to the AC outlet securely and not loose?
- (3) Does not connected cable do wrong wiring?
- (4) Check if each connector is inserted securely.

[Checking Flow Chart]

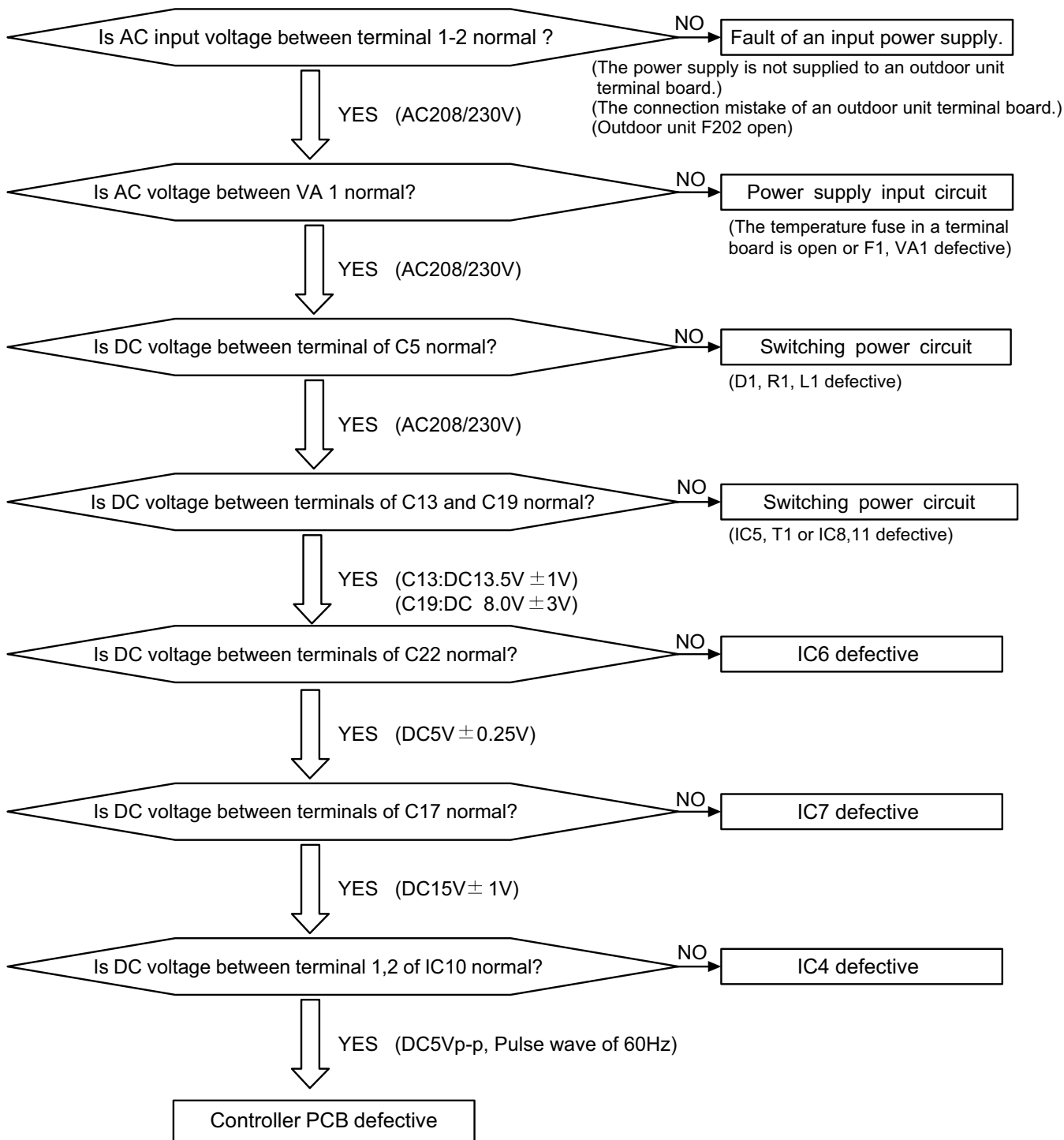

SELF-DIAGNOSIS FUNCTION

This function memorizes the self-diagnosis function (lamp display) in the in door control P.C.Board when trouble occurs.

(The memory contents are not destroyed even when the power cord is unplugged from the AC outlet.)

The self-diagnosis function (lamp display) can also be switched between major classification display and minor classification display and precise diagnosis can be made.

Self-diagnosis function [lamp display] (memory reading)

(1) When error occurs, it is indicated by blinking [Operation lamp (Red)] and [Timer lamp (Green)].

(2) Upon pulling out and inserting the AC plug, the starts to operates from remote control.
(At this state, a normal operation indication is performed.)

(3) By pressing [TEST] button of remote control, [Error Indication] is indicated only

during

[3 minutes ST].

(3 minutes ST : 2 minutes 20 seconds from the timing AC plug is ON)

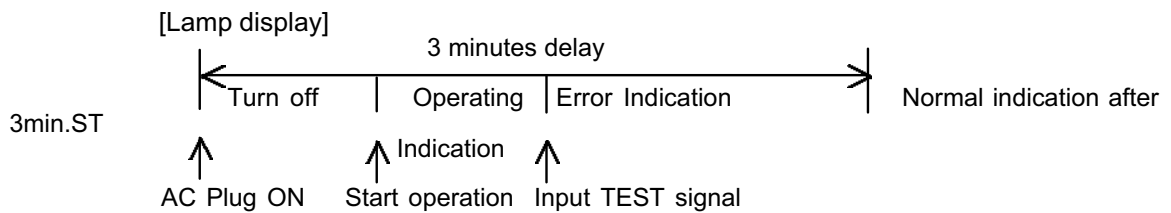

How to erase Memory

(1)

While [Error indication] is ON by the self-diagnosis function, the memorized contents can be erased by pressing [Forced Auto Button] on the main unit.

(Indoor unit buzzer beeps 3 seconds.)

Self - diagnosis function and Checking points

Error Indication		Wired remote controller	Error (Protection)	Diagnosis Method
Operation (RED)	Timer (GREEN)			
OFF	0.5 sec 2 times	01	Serial reverse transfer error at starting up operation	At the start up, the indoor unit does not receive the signal for 10 consecutive seconds from the time when the power relay was ON. >Permanent stop after 30 seconds. [Diagnosis Point] • Check the indoor /outdoor cable connection (in order). If the cable wiring is not abnormal, measure the voltage of the outdoor unit terminals and diagnose the defective location. (Refer to the after mentioned [Serial Signal Diagnosis] for the voltage measuring method and diagnosis method.)
	0.5 sec 3 times	01	Serial reverse transfer error during the operation	When the indoor unit does not receive the signal for 10 consecutive seconds during the operation >Permanent stop after 30 seconds. [Diagnosis Point] • Check the indoor /outdoor cable connection (in order). If the cable wiring is not abnormal, measure the voltage of the outdoor unit terminals and diagnose the defective location. (Refer to the after mentioned [Serial Signal Diagnosis] for the voltage measuring method and diagnosis method.)
	0.5 sec 4 times	13	Serial forward transfer error at starting up operation	The outdoor unit does not receive the signal for 10 consecutive seconds from the time when the power relay was ON. >Outdoor unit stops. [Diagnosis Point] • Check the indoor /outdoor cable connection (in order). If the cable wiring is not abnormal, measure the voltage of the outdoor unit terminals and diagnose the defective location. (Refer to the after mentioned [Serial Signal Diagnosis] for the voltage measuring method and diagnosis method.)
	0.5 sec 5 times	13	Serial forward transfer error during the operation	When the outdoor unit does not receive the signal for 10 consecutive seconds during the operation > Outdoor unit stops. [Diagnosis Point] • Check the indoor /outdoor cable connection (in order). If the cable wiring is not abnormal, measure the voltage of the outdoor unit terminals and diagnose the defective location. (Refer to the after mentioned [Serial Signal Diagnosis] for the voltage measuring method and diagnosis method.)
0.5 sec 2 times	0.5 sec 2 times	02	Room temperature thermistor defective	The room temperature thermistor detective a abnormal temperature when the power was turned on. > Remote control does not operate. [Diagnosis Point] • Check thermistor resistance value (Refer to "Thermistor characteristics table"). • Controller PCB defective.
	0.5 sec 3 times	04	Indoor heat exchanger thermistor error	The detection value of the indoor heat exchanger thermistor is either open or shoted when the power is ON. > Remote control dose not operate. [Diagnosis Point] • Check thermistor resistance value (Refer to "Thermistor characteristics table"). • Controller PCB defective.

Self - diagnosis function and Checking points

Error Indication		Wired remote controller	Error (Protection)	Diagnosis Method
Operation (RED)	Timer (GREEN)			
0.5 sec 3 times	0.5 sec 2 times	00	Discharge thermistor error	The detection value of the discharge thermistor is either open or shorted. > Compressor, outdoor fan : OFF (It automatically releases when the normal value is detected.) [Diagnosis Point] • Check thermistor resistance value (Refer to "Thermistor characteristics table"). • Controller PCB defective.
0.5 sec 3 times	0.5 sec 3 times	06	Outdoor heat exchanger thermistor error	The detection value of the outdoor heat exchanger thermistor is either open or shorted. > Compressor, outdoor fan : OFF (It automatically releases when the normal value is detected.) [Diagnosis Point] • Check thermistor resistance value (Refer to "Thermistor characteristics table"). • Controller PCB defective.
0.5 sec 4 times	0.5 sec 4 times	0A	Outdoor temperature thermistor error	The detection value of the outdoor temperature thermistor is either open or shorted. > Compressor, outdoor fan : OFF (It automatically releases when the normal value is detected.) [Diagnosis Point] • Check thermistor resistance value (Refer to "Thermistor characteristics table"). • Controller PCB defective.
0.5 sec 4 times	0.5 sec 2 times	No Display	Forced auto switch error	Forced auto switch becomes ON for 30 consecutive seconds. > It indicates the error but the operation continues. [Diagnosis Point] • Check if forced auto switch is kept pressed. • Forced auto switch defective. • Controller PCB defective.
0.5 sec 3 times	0.5 sec 3 times	No Display	Main relay error	After 2 minutes 20 seconds of stopping operation, the signal from outdoor unit is received even though the main relay is OFF. > Main relay OFF continues (outdoor unit OFF command) [Diagnosis Point] • Main relay defective • Controller PCB defective.
0.5 sec 4 times	0.5 sec 4 times	No Display	Power supply frequency detection error	The power supply frequency can not be recognized after 4 seconds of power ON. > Permanent stop. [Diagnosis Point] • Controller PCB defective.

Self - diagnosis function and Checking points

Error Indication		Wired remote controller	Error (Protection)	Diagnosis Method
Operation (RED)	Timer (GREEN)			
0.5 sec 4 times	0.5 sec 7 times	No Display	VDD permanence stop protection (Electric air clean)	When the air cleanness monitor trial protection operates 4 times. > Only clean air permanent stop. [Diagnosis Point] • The front panel is closed. • The foreign body such as dust doesn't adhere.
0.5 sec 5 times	0.5 sec 8 times	21	Reverse-VDD permanence stop protection (Electric air clean power supply circuit abnormal)	The air clean operation signal was detected for 1 minute at the time of air clean mode OFF. > All stop. Not operate remote controller. [Diagnosis Point] • Electric air clean defective. • Controller PCB defective.
0.5 sec 5 times	0.5 sec 2 times	17	IPM protection	Abnormal current value of IPM is detected. > Permanent stop. [Diagnosis Point] • Heat radiation is blocked (inlet/outlet). • Check if outdoor fan is defective (does not rotate). • Controller PCB defective (Refer to after mentioned "IPM diagnosis"). • Refrigeration cycle defective (Refer to after mentioned "refrigeration cycle diagnosis").
0.5 sec 5 times	0.5 sec 3 times	18	CT error	The current value during the operation after 1 minute from starting up the compressor is 0A. > permanent stop. [Diagnosis Point] • Check if CT wire is open. • Controller PCB defective.
0.5 sec 5 times	0.5 sec 5 times	1A	Compressor location error	The compressor speed does not synchronize with the control signal. (Including start up failure of the compressor). > permanent stop. [Diagnosis Point] • Check if 2-way valve or 3-way valve is left open. • Check the compressor (Winding resistance value, loose lead wire). • Refrigeration cycle defective (Refer to after mentioned "refrigeration cycle diagnosis")
0.5 sec 6 times	0.5 sec 6 times	1B	Outdoor fan error (DC motor)	Either the outdoor fan motor abnormal current or location error was detected. > Permanent stop. [Diagnosis Point] • Fan motor connector loose/ defective contact. • Fan motor defective. • Controller PCB defective.

Self - diagnosis function and Checking points

Error Indication		Wired remote controller	Error (Protection)	Diagnosis Method
Operation (RED)	Timer (GREEN)			
0.5 sec 6 times	0.5 sec 2 times	No Display	Indoor fan lock error	The indoor fan speed is 0 rpm after 56 seconds from starting operation or from the time the fan mode was changed. > Operation stop. (It releases by sending the operation stop signal from the remote controller). [Diagnosis Point] <ul style="list-style-type: none"> • Fan motor connector loose /defective contact. • Fan motor defective • Controller PCB defective.
	0.5 sec 3 times	No Display	Indoor fan speed error	The indoor fan speed is 1/3 of the target frequency after 56 seconds from starting operation or from the time the fan mode was changed. > Operation stop. (It releases by sending the operation stop signal from the remote controller). [Diagnosis Point] <ul style="list-style-type: none"> • Fan motor connector loose /defective contact. • Fan motor defective • Controller PCB defective.
0.5 sec 7 times	0.5 sec 2 times	OF	Discharge temperature error	The discharge temperature error is activated. > Permanent stop. [Diagnosis Point] <ul style="list-style-type: none"> • Check if 2-way valve or 3-way valve is left open. • Heat radiation is blocked (Inlet /outlet). • Check if outdoor fan is defective (does not rotate). • Refrigeration cycle defective (Refer to after mentioned "refrigerant cycle diagnosis").
	0.5 sec 3 times	24	Excessive high pressure protection on cooling	Excessive high pressure protection on cooling mode has been activated. > Compressor, outdoor fan : Off (It releases after 3 minute ST). [Diagnosis Point] <ul style="list-style-type: none"> • Heat radiation is blocked (Inlet /outlet). • Check if outdoor fan is defective (does not rotate). • Refrigeration cycle defective (Refer to after mentioned "refrigerant cycle diagnosis").
0.5 sec 8 times	0.5 sec 4 times	25	PFC circuit error	Excessive voltage of DC voltage on PFC circuit in inverter PCB is detected, or the excessive current in the circuit is detected. > Permanent stop. [Diagnosis Point] <ul style="list-style-type: none"> • Controller PCB defective (Refer to after mentioned "PFC circuit diagnosis") • •

Serial Signal Receiving Error

[Check Point] Check which has a cause of error, either Indoor unit or Outdoor unit.

- * Remove indoor unit front panel and cable xlampers and keep the terminal block clear so that it can be measured with a meter.
- * Remove AC power and reset the power, and press Test Operation switch on remote control.

[Check Procedure]

CAUTION: Keep out hands from terminal base and electrical components. Voltage is applied on them and you may get electric shock.

[Indoor Unit Check]

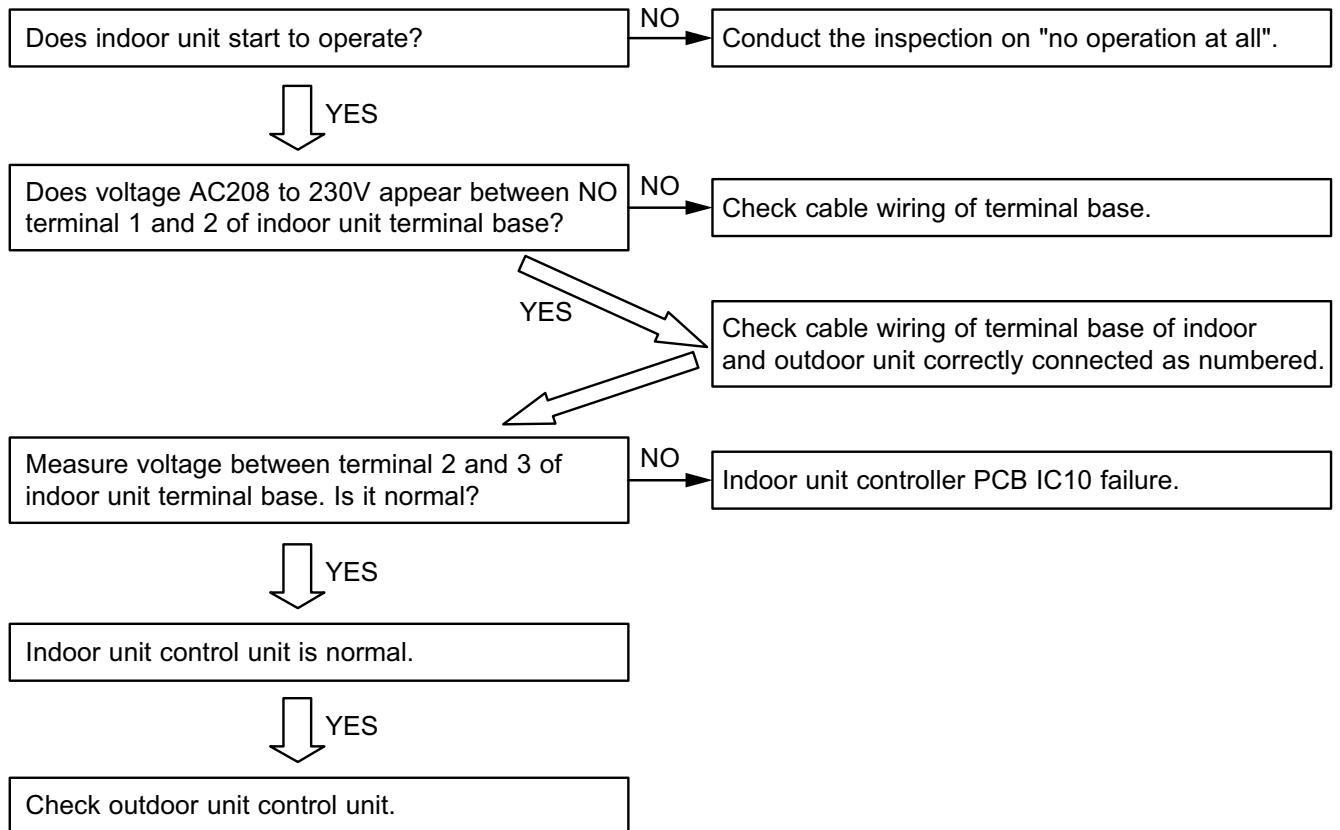

[Outdoor Unit Check]

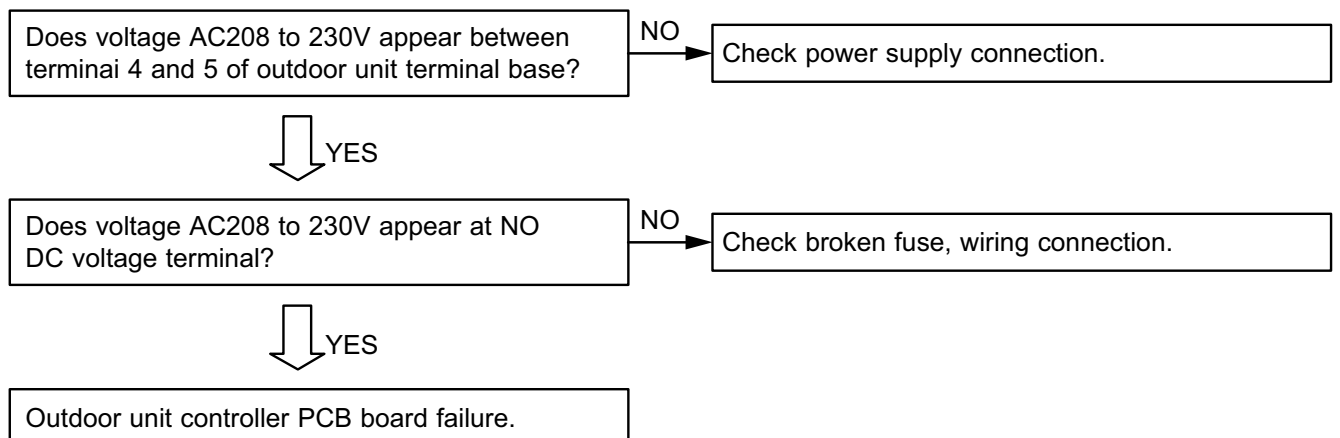

IPM Protection

[Checking Points]

Check the following points and locate the cause in the outdoor unit.

[Cause]

- (1) Compressor failure
- (2) Refrigeration cycle failure
- (3) PC Board defective
- (4) IPM defective
- (5) Incorrect wiring

[First step]

Measure the DC voltage at terminals (between Electrolytic Capacitor and discharge resistance) in the Inverter Controller Assy, and make sure it is lower than DC5V.

If it is higher than 5V, wait until the discharging is over.

Check point (1)

Open the Inverter Controller Assy and check if there is abnormal points.

No(Abnormal)



Incorrect wiring > Correct and recheck
Parts touched > Correct and recheck
Parts broken > Change the broken part



Yes(Normal)

Go to Check point (2)

Check point (2)

Turn on the power and press TEST button on Remote Control.
Is the outdoor fan rotating?



No(Not rotating)

IPM or PCB defective > Replace PCB



Yes(Rotating)

Go to Check point (3)

Check point (3)

Operate the unit for certain time and check if the compressor is operating.



No(Not operating)

IPM or PCB defective > Replace PCB



Yes(Operating)

The unit is normal.

Recheck

Operate the unit for certain time and check if the compressor is operating.

Yes(Operating) > Check completed

No(Not operating) > Return to the start

Trouble Shooting of Refrigerant Cycle

[Diagnosis Table for Defective Component]

○: Item of most possible cause

	IPM Protection	Compressor Location error	Discharge Temperature Error	Cooling High Pressure Protection
Refrigerant leak			○	
Compressor failure(*)	○	○		
EEV failure (*)	○	○	○	○
Thermistor failure (*)	○	○	○	○

(*) Trouble Shooting Method

(1) Checking method of the compressor failure

Insert the AC plug and start up the cooling operation. Input Test operation signal and check if the compressor operates.

If it does not operate, measure the resistance value of compressor windings between U-V, V-W, W-U.

If any of the resistance value between U-V, V-W, W-U is not same as others, the compressor is defective.

Compressor Failure

	NORMAL
ASU9/12RLQ	Compressor Case Temperature at 68°F(20°C): 0.710 ohm
ASU18CL/RL	Compressor Case Temperature at 68°F(20°C): 0.730 ohm

(The above resistance value is a typical value. There is some distribution. As it also changes by the compressor temperature, the measured value may be much different from the above table when measured right after stopping operation.)

(2) Checking method of EEV failure

- Insert the AC plug and start up the operation. Check if the EEV operates just before compressor is turned on. (Touch EEV by hand and check it.)

If it does not operate, check if the coil or connector of EEV is removed or loose.

If it operates, check the discharge thermistor / outdoor heat exchanger thermistor / indoor heat exchanger thermistor. (Refer to (3) for checking method.)

(3) Checking method of Thermistor

- Check each thermistor if it is removed or the connector is loose.

If there is no problem, remove the connector of the thermistor from the PCB and check the resistance value (refer to the thermistor characteristics table).

WALL MOUNTED type INVERTER

8 . APPENDING DATA

1. Jumper setting of Indoor unit and Outdoor unit
2. Outdoor unit Pressure Value and Total Electric Current Curve
3. Thermistor Resistance Values
4. Capacity/Input data

JP (Jumper) Setting

[Indoor Unit]

ASU9/12RLQ
ASU18CL/RL

- Remote control custom code

When multiple number of indoor units are installed in the same room, erroneous receipt of the signal can be avoided by setting up the remote control custom code separately.

To set up the remote control custom code, always set up the same code on both indoor unit PCB and remote control PCB.

(When the indoor unit PCB is changed to Code B, it can not receive the signal unless remote control PCB is also changed to Code B.)

	Indoor Unit	Remote Control
	JM3(JP)	J4 (JP)
Code A (Default)	YES	YES
Code B	NO	NO

- Auto Restart

It is possible to disengage Auto Restart function if it is not needed.

	Indoor Unit
	JM2 (JP)
With Auto Restart function (Default)	YES
Without Auto Restart function	NO

[Outdoor Unit]

AOU9/12RLQ, AOU18CL/RL

	JP
	JM500
Normal Preheat	YES
Higher Preheat	NO

- it is possible to select the higher or standard level of preheating function.

- When it is set up at the higher level of preheat, the magnetic noise of the compressor becomes higher.

Outdoor Unit Low Pressure Value and Outdoor Total Electric Current Curve (Cooling)

Model Name : ASU9RLQ, ASU12RLQ

[Condition]

Ambient Indoor / Outdoor - Same temperature
temperatur

Refrigerant Standard amount
amount

Piping 7.5m (Height difference 1m)
length

Power 60Hz - 230V
voltage

Operation TEST mode (Cooling), Hi Fan, Horizontal direction, Front air flow
condition

Measuring Measure the low pressure with the pressure meter at the service valve. Measure the
method outdoor unit overall current with the current clamp meter at Power Cable.

Caution Start operation with the condition of the Indoor Unit air filter clean.

[Constant Frequency Operation Method (Test mode)]

1. Operate on Colling mode, and press TEST button of remote control.
2. Operate continuously for 30 minutes. (After 60 minutes of operation, Test mode is released automatica

(1) Indoor/Outdoor Temperature - Outdoor Low Pressure Curve

ASU9RLQ series

ASU12RLQ series

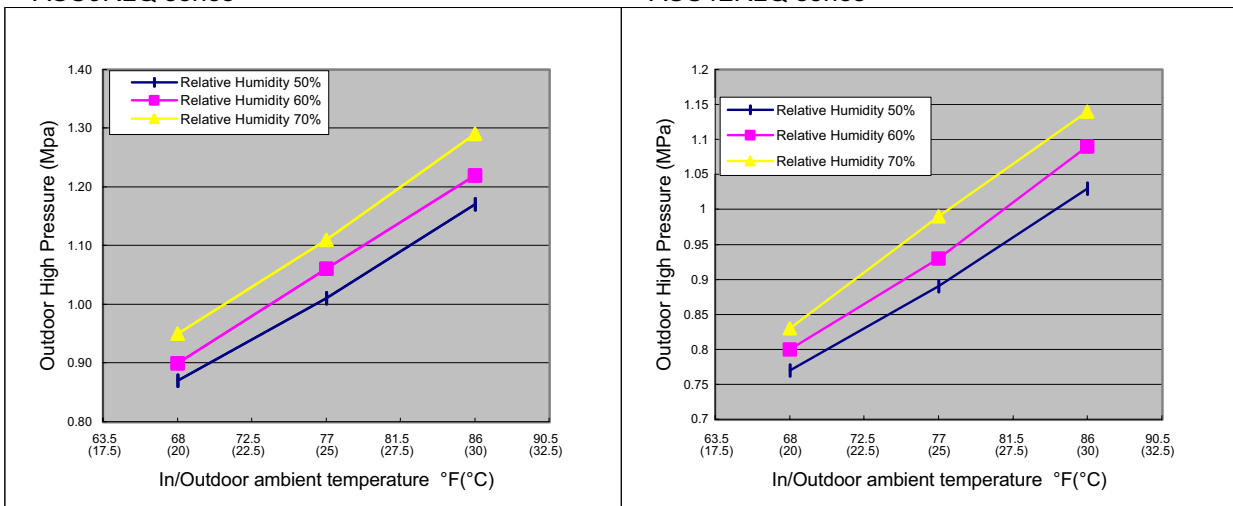

(2) Indoor/Outdoor Temperature - Outdoor Total Electric Current Curve

ASU9RLQ series

ASU12RLQ series

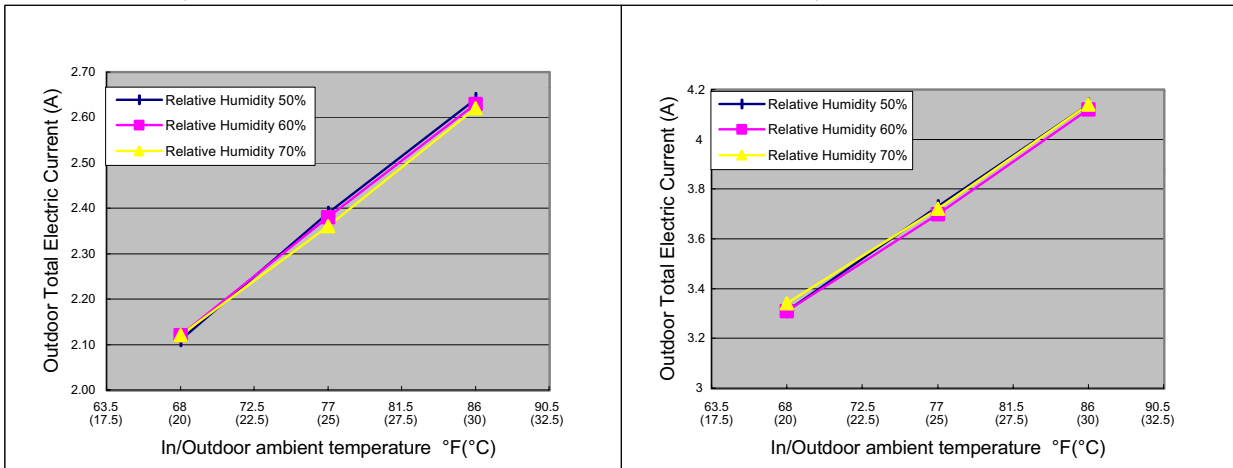

Outdoor Unit High Pressure Value and Outdoor Total Electric Current Curve (Heating)

Model Name : ASU9RLQ, ASU12RLQ

[Condition]

Ambient temperature Indoor 15 - 23degC, Outdoor 2 - 12degC

Refrigerant amount Standard amount

Piping length 7.5m (Height difference 1m)

Power voltage 60Hz - 230V

Operation condition TEST mode (Heating), Hi Fan, Lower direction, Front air flow

Measuring method Measure the high pressure with the pressure meter at the service valve. Measure the outdoor unit overall current with the current clamp meter at Power Cable.

Caution Start operation with the condition of the Indoor Unit air filter clean.

[Constant Frequency Operation Method (Test mode)]

1. Operate on Heating mode, and press TEST button of remote control.
2. Operate continuously for 30 minutes. (After 60 minutes of operation, Test mode is released automat

(1) Indoor/Outdoor Temperature - Outdoor High Pressure Curve

ASU9RLQ series

ASU12RLQ series

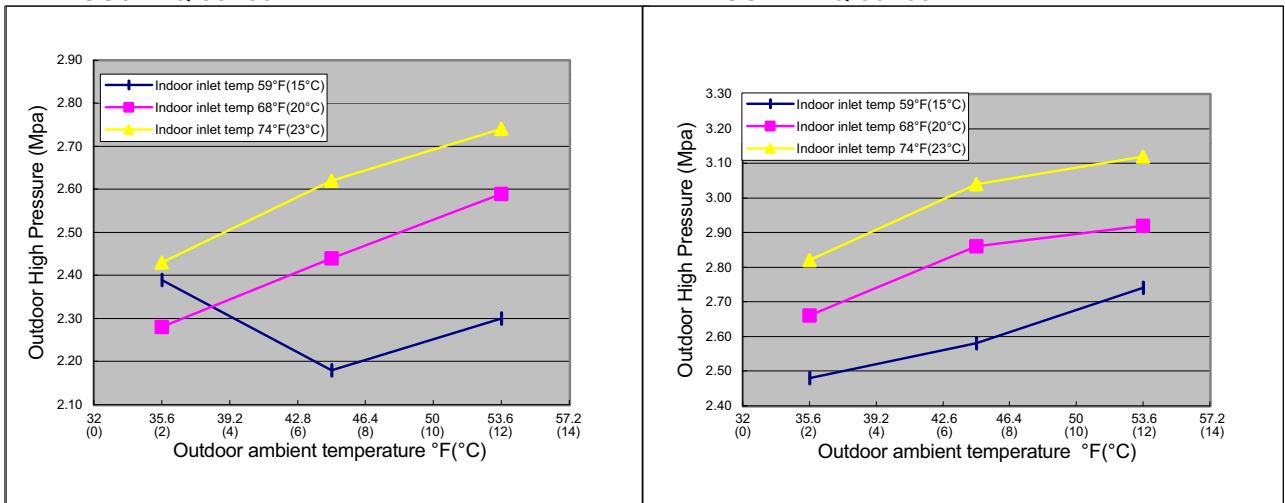

(2) Indoor/Outdoor Temperature - Outdoor Total Electric Current Curve

ASU9RLQ series

ASU12RLQ series

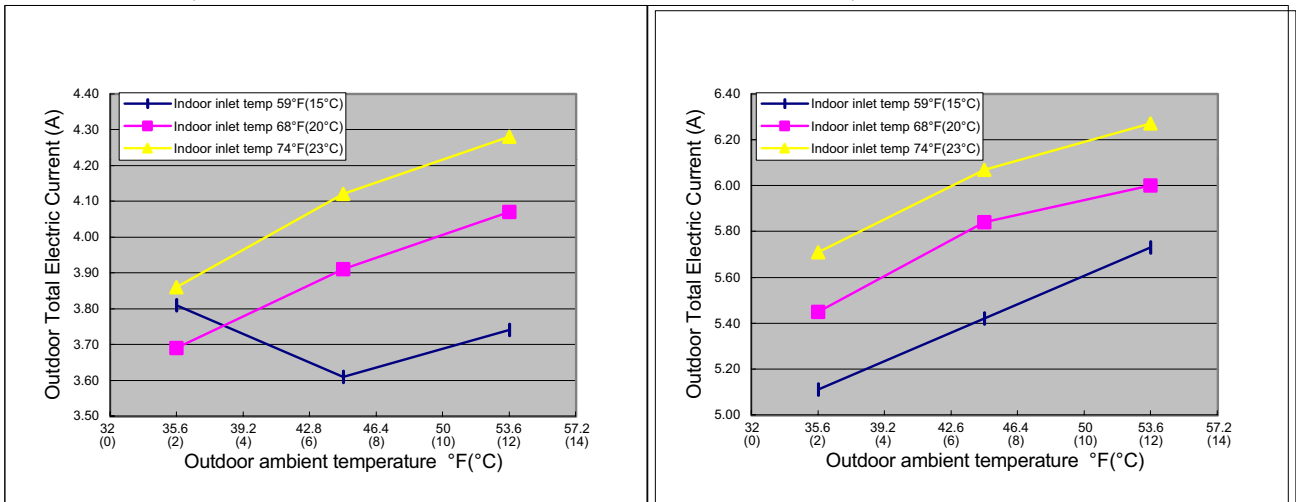

Outdoor Unit Low Pressure Value and Outdoor Total Electric Current Curve (Cooling)

Model Name : ASU18CL, ASU18RL

[Condition]

Ambient temperature Indoor / Outdoor - Same temperature

Refrigerant amount Standard amount

Piping length 7.5m (Height difference 1m)

Power voltage 60Hz - 230V

Operation condition TEST mode (Cooling), Hi Fan, Horizontal direction, Front air flow

Measuring method Measure the low pressure with the pressure meter at the service valve. Measure the outdoor unit overall current with the current clamp meter at Power Cable.

Caution Start operation with the condition of the Indoor Unit air filter clean.

[Constant Frequency Operation Method (Test mode)]

1. Operate on Colling mode, and press TEST button of remote control.
2. Operate continuously for 30 minutes. (After 60 minutes of operation, Test mode is released automatically.)

(1) Indoor/Outdoor Temperature - Outdoor Low Pressure Curve ASU18CL/RL series

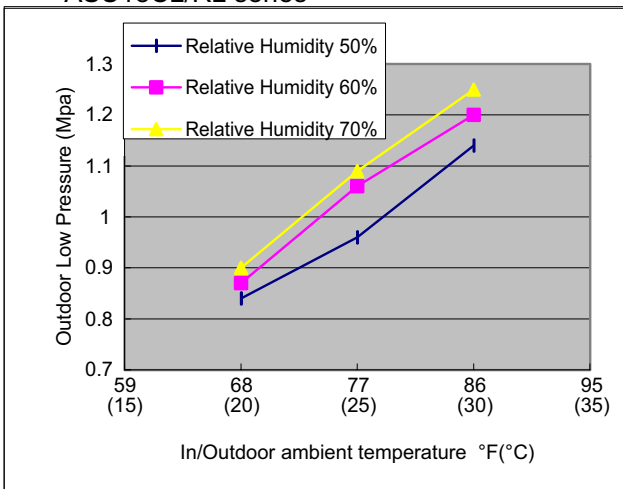

(2) Indoor/Outdoor Temperature - Outdoor Total Electric Current Curve ASU18CL/RL series

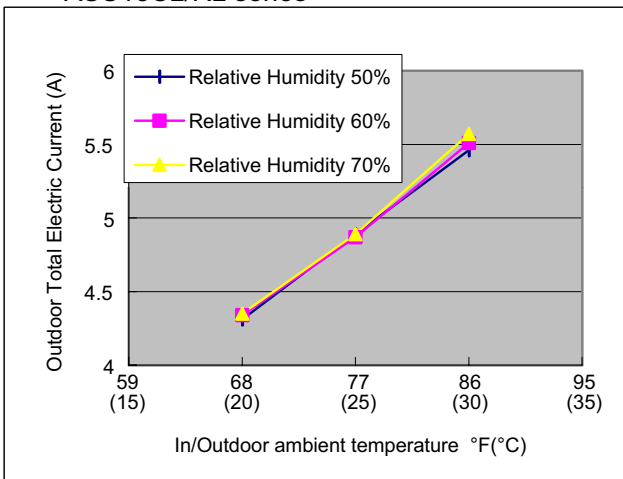

Outdoor Unit High Pressure Value and Outdoor Total Electric Current Curve (Heating)

Model Name : AS18RL

[Condition]

Ambient temperature Indoor 15 - 23degC, Outdoor 2 - 12degC

Refrigerant amount Standard amount

Piping length 7.5m (Height difference 1m)

Power voltage 60Hz - 230V

Operation condition TEST mode (Heating), Hi Fan, Lower direction, Front air flow

Measuring method Measure the high pressure with the pressure meter at the service valve. Measure the outdoor unit overall current with the current clamp meter at Power Cable.

Caution Start operation with the condition of the Indoor Unit air filter clean.

[Constant Frequency Operation Method (Test mode)]

1. Operate on Heating mode, and press TEST button of remote control.
2. Operate continuously for 30 minutes. (After 60 minutes of operation, Test mode is released automatically.)

(1) Indoor/Outdoor Temperature - Outdoor High Pressure Curve ASU18RL

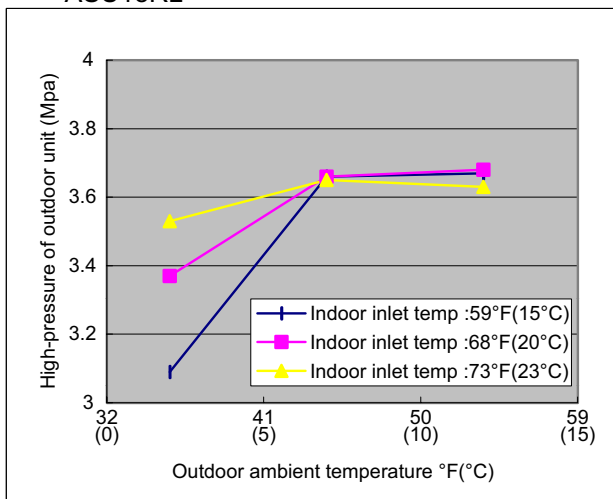

(2) Indoor/Outdoor Temperature - Outdoor Total Electric Current Curve ASU18RL

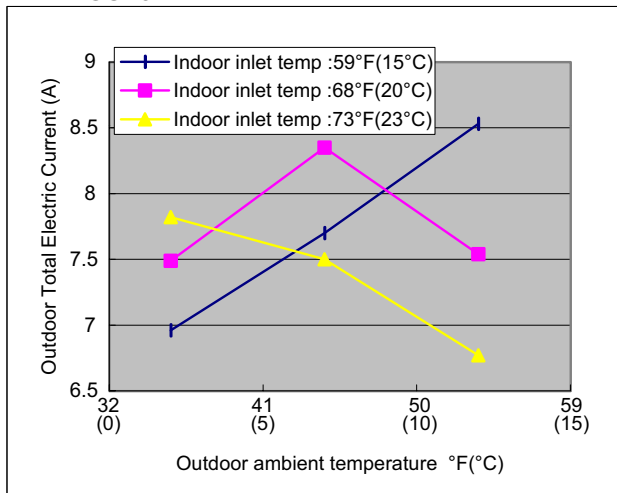

Thermistor resistance values

Room temperature thermistor		
Temp °F(°C)	Resistance kΩ	Voltage (V)
32.00 (0.00)	33.62	1.15
41.00 (5.00)	25.93	1.39
50.00 (10.00)	20.18	1.66
59.00 (15.00)	15.84	1.94
68.00 (20.00)	12.54	2.22
77.00 (25.00)	10.00	2.50
86.00 (30.00)	8.04	2.77
95.00 (35.00)	6.51	3.03
104.00 (40.00)	5.30	3.27
113.00 (45.00)	4.35	3.48
122.00 (50.00)	3.59	3.68
131.00 (55.00)	2.98	3.85
140.00 (60.00)	2.47	4.00
149.00 (65.00)	2.09	4.14
158.00 (70.00)	1.76	4.25
167.00 (75.00)	1.49	4.35
176.00 (80.00)	1.27	4.44
185.00 (85.00)	1.09	4.51
194.00 (90.00)	0.93	4.57
203.00 (95.00)	0.81	4.63
212.00 (100.00)	0.70	4.67

Indoor heat exchanger thermistor		
Temp °F(°C)	Resistance kΩ	Voltage (V)
32.00 (0.00)	176.03	1.10
41.00 (5.00)	134.23	1.36
50.00 (10.00)	103.34	1.63
59.00 (15.00)	80.28	1.92
68.00 (20.00)	62.91	2.21
77.00 (25.00)	49.70	2.51
86.00 (30.00)	39.57	2.79
95.00 (35.00)	31.74	3.06
104.00 (40.00)	25.64	3.30
113.00 (45.00)	20.85	3.53
122.00 (50.00)	17.06	3.73
131.00 (55.00)	14.10	3.90
140.00 (60.00)	11.64	4.55
149.00 (65.00)	9.69	4.19
158.00 (70.00)	8.12	4.30
167.00 (75.00)	6.83	4.40
176.00 (80.00)	5.78	4.48
185.00 (85.00)	4.91	4.55
194.00 (90.00)	4.19	4.61
203.00 (95.00)	3.59	4.66
212.00 (100.00)	3.09	4.71

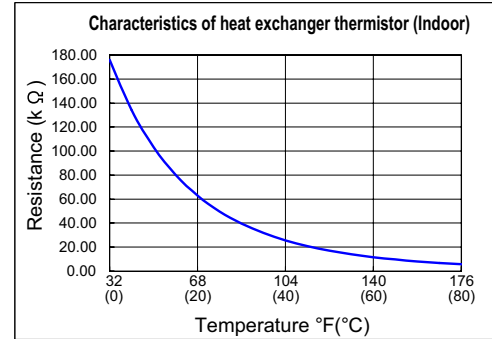
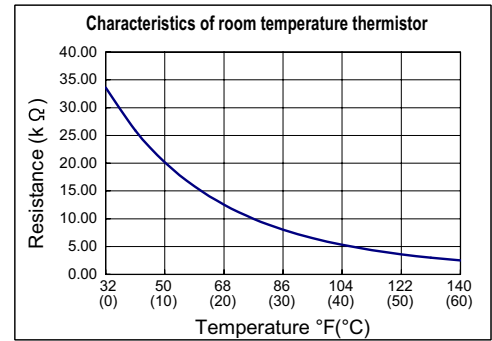

Discharge thermistor		
Temp °F(°C)	Resistance kΩ	Voltage (V)
32.00 (0.00)	175.70	0.18
41.00 (5.00)	134.93	0.24
50.00 (10.00)	104.59	0.30
59.00 (15.00)	81.79	0.31
68.00 (20.00)	64.50	0.38
77.00 (25.00)	51.27	0.47
86.00 (30.00)	41.07	0.70
95.00 (35.00)	33.13	0.84
104.00 (40.00)	26.91	0.99
113.00 (45.00)	22.01	1.16
122.00 (50.00)	18.10	1.34
131.00 (55.00)	14.98	1.54
140.00 (60.00)	12.47	1.74
149.00 (65.00)	10.44	1.95
158.00 (70.00)	8.78	2.16
167.00 (75.00)	7.42	2.36
176.00 (80.00)	6.31	2.57
185.00 (85.00)	5.38	2.76
194.00 (90.00)	4.61	2.95
203.00 (95.00)	3.97	3.13
212.00 (100.00)	3.43	3.30
221.00 (105.00)	2.98	3.45
230.00 (110.00)	2.59	3.60
239.00 (115.00)	2.26	3.73
248.00 (120.00)	1.99	3.85

Outdoor heat exchanger thermistor		
Temp °F(°C)	Resistance kΩ	Voltage (V)
-4.00 (-20.00)	49.20	2.66
5.00 (-15.00)	36.58	3.02
14.00 (-10.00)	27.51	3.35
23.00 (-5.00)	20.91	3.64
32.00 (0.00)	16.05	3.89
41.00 (5.00)	12.44	4.09
50.00 (10.00)	9.73	4.26
59.00 (15.00)	7.67	4.40
68.00 (20.00)	6.10	4.51
77.00 (25.00)	4.89	4.60
86.00 (30.00)	3.95	4.67
95.00 (35.00)	3.21	4.73
104.00 (40.00)	2.62	4.78
113.00 (45.00)	2.16	4.81
122.00 (50.00)	1.79	4.85
131.00 (55.00)	1.49	4.87
140.00 (60.00)	1.25	4.89
149.00 (65.00)	1.05	4.91
158.00 (70.00)	0.89	4.92
167.00 (75.00)	0.76	4.93
176.00 (80.00)	0.65	4.94
185.00 (85.00)	0.56	4.95
194.00 (90.00)	0.48	4.96
203.00 (95.00)	0.41	4.96
212.00 (100.00)	0.36	4.97

Outdoor temperature thermistor		
Temp °F(°C)	Resistance kΩ	Voltage (V)
-4.00 (-20.00)	115.24	1.25
5.00 (-15.00)	84.21	1.56
14.00 (-10.00)	62.28	1.90
23.00 (-5.00)	46.58	2.26
32.00 (0.00)	35.21	2.61
41.00 (5.00)	26.88	2.94
50.00 (10.00)	20.72	3.25
59.00 (15.00)	16.12	3.52
68.00 (20.00)	12.64	3.76
77.00 (25.00)	10.00	3.97
86.00 (30.00)	7.97	4.14
95.00 (35.00)	6.40	4.28
104.00 (40.00)	5.18	4.41
113.00 (45.00)	4.21	4.51
122.00 (50.00)	3.45	4.59
131.00 (55.00)	2.85	4.65
140.00 (60.00)	2.36	4.71
149.00 (65.00)	1.97	4.76
158.00 (70.00)	1.65	4.79
167.00 (75.00)	1.39	4.83
176.00 (80.00)	1.18	4.85
185.00 (85.00)	1.00	4.87
194.00 (90.00)	0.85	4.89
203.00 (95.00)	0.73	4.91
212.00 (100.00)	0.63	4.92

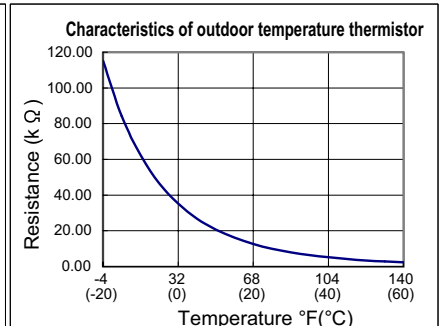
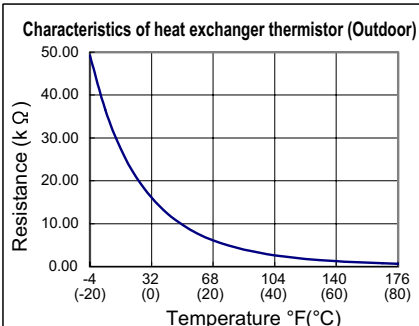
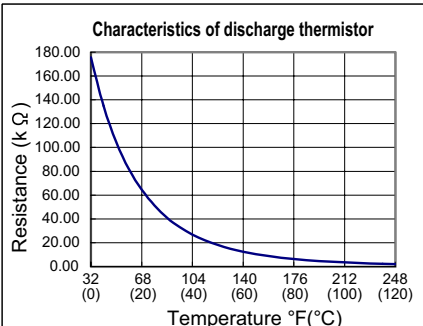

ASU9RLQ Capacity/Input data

Heating

<Capacity>

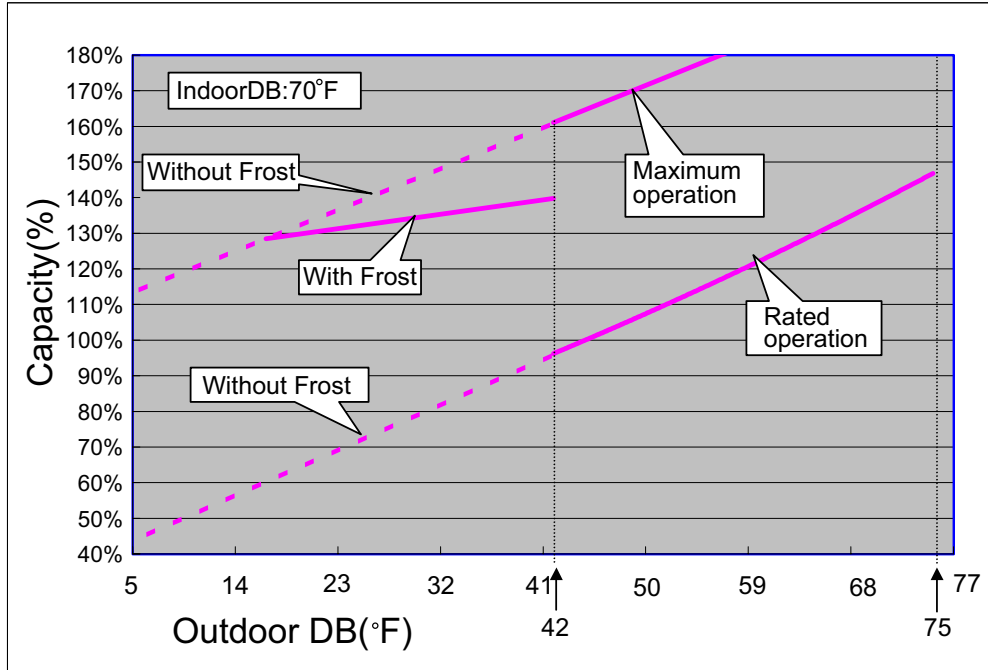

<Input>

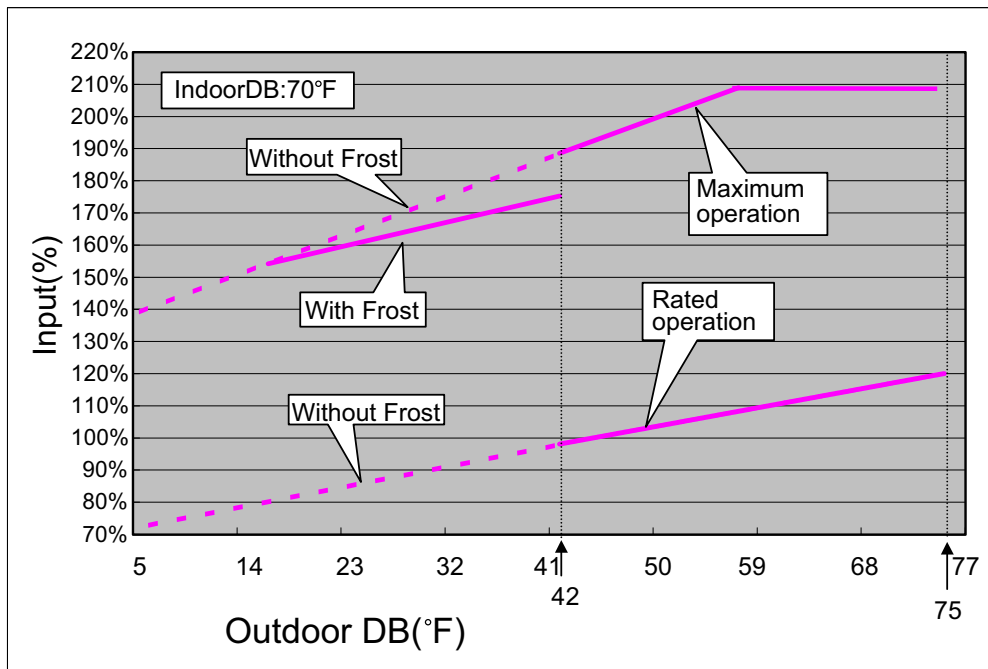

- *Defrosting operation is performed when temperature is less than 42 degrees F. Frost appears on an outdoor unit heat exchanger at 42 or less degrees F.
- *Solid line: Integral capacity/Input containing the defrosting cycle.
- *Dotted line: Capacity/Input which does not contain the defrosting cycle.

Cooling

<Capacity>

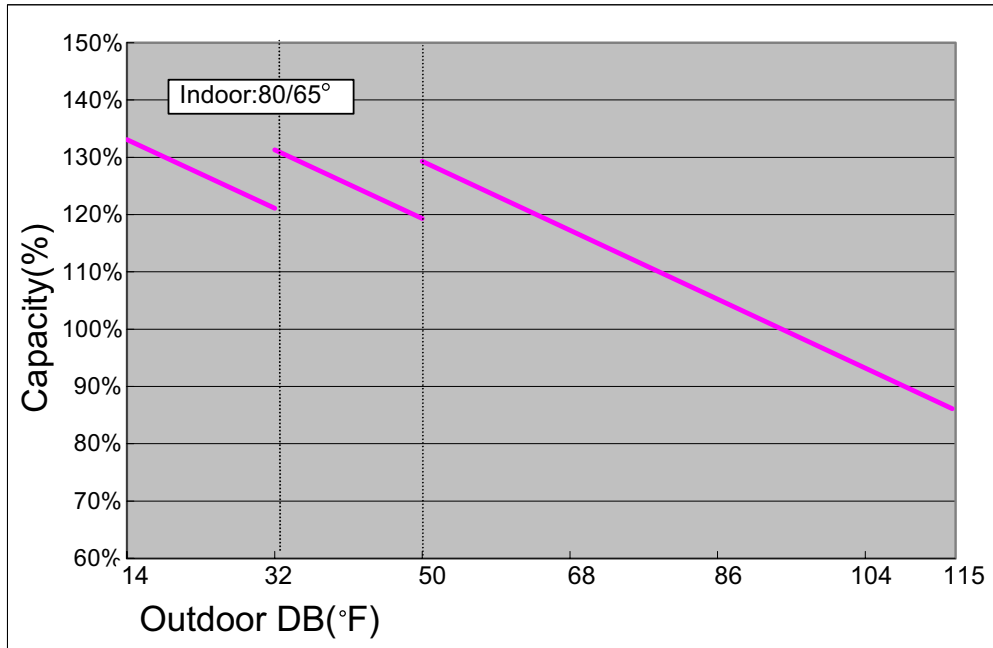

<Input>

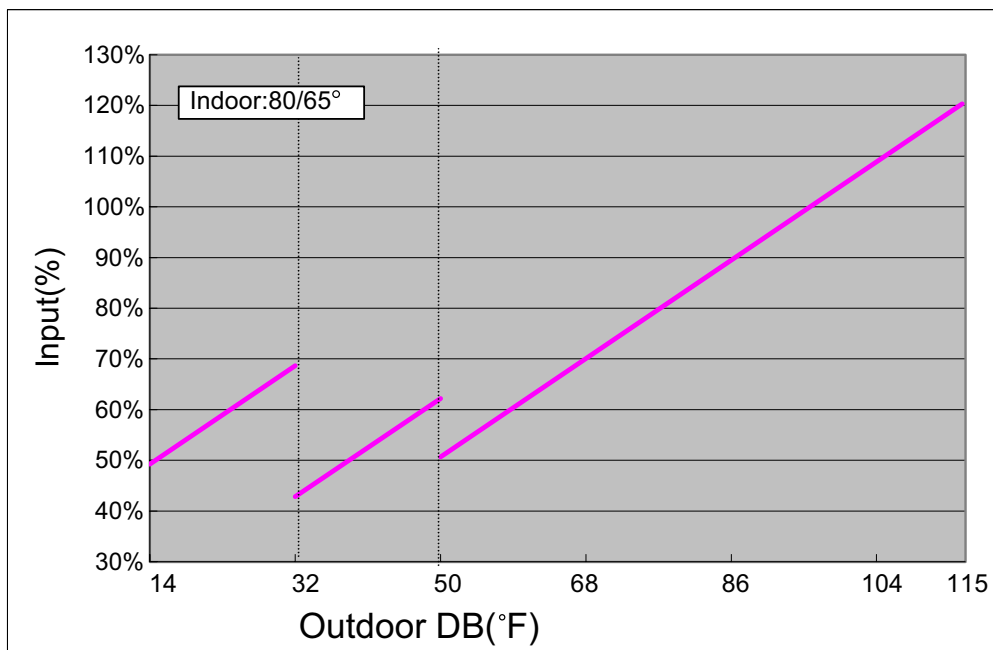

*Both capacity and input change largely when temperature is 50 or less degrees F, as outdoor fan speed is decreased due to low ambient temperature cooling control.

*Both capacity and input change more largely at less than 32 degrees F of ambient temperature as outdoor fan speed is decreased further.

ASU12RLQ Capacity/Input data

Heating

<Capacity>

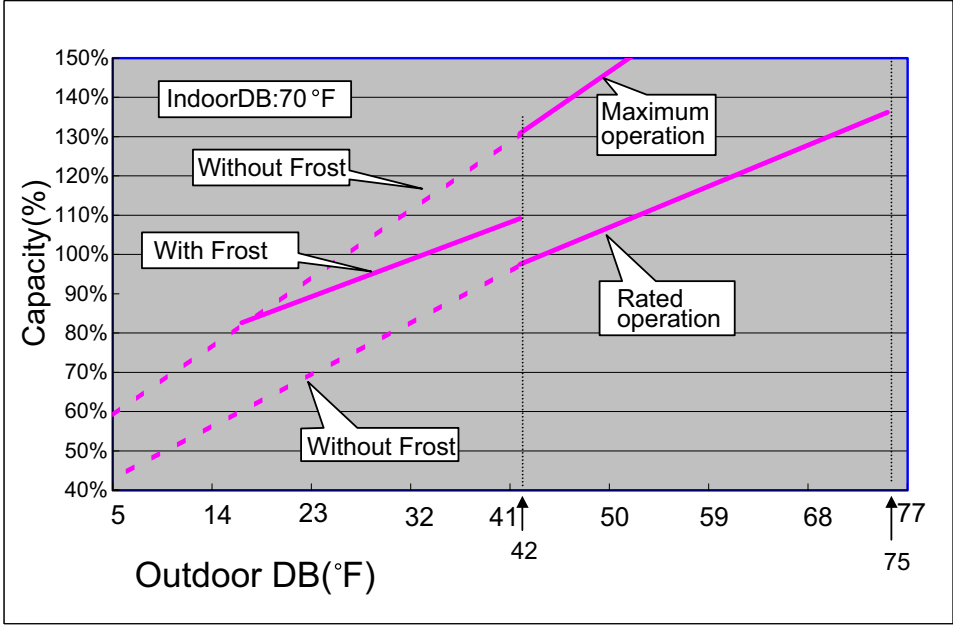

<Input>

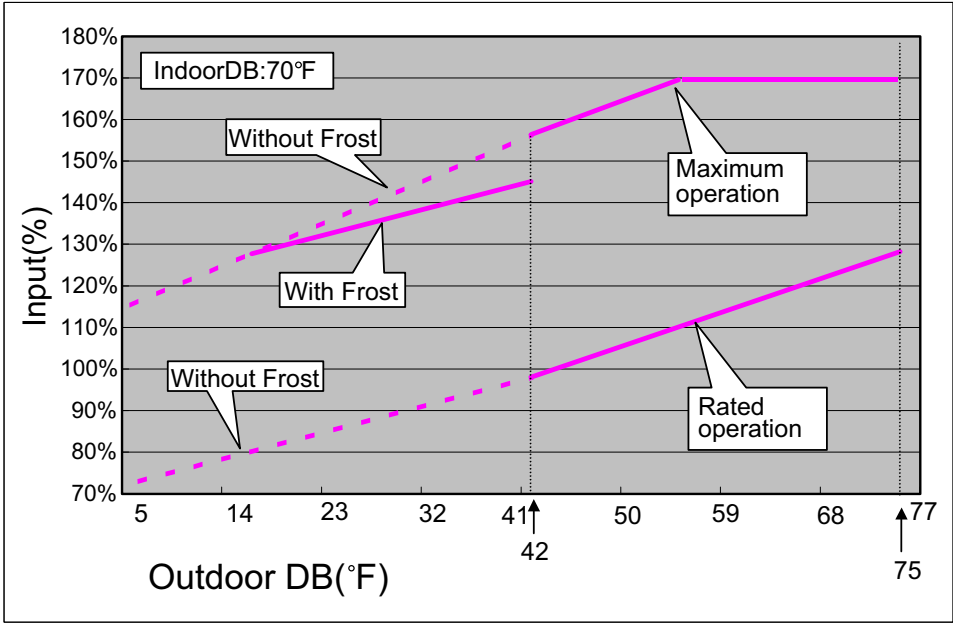

- * Defrosting operation is performed when temperature is less than 42 degrees F. Frost appears on an outdoor unit heat exchanger at 42 or less degrees F.
- * Solid line: Integral capacity/Input containing the defrosting cycle.
- * Dotted line: Capacity/Input which does not contain the defrosting cycle.

Cooling

<Capacity>

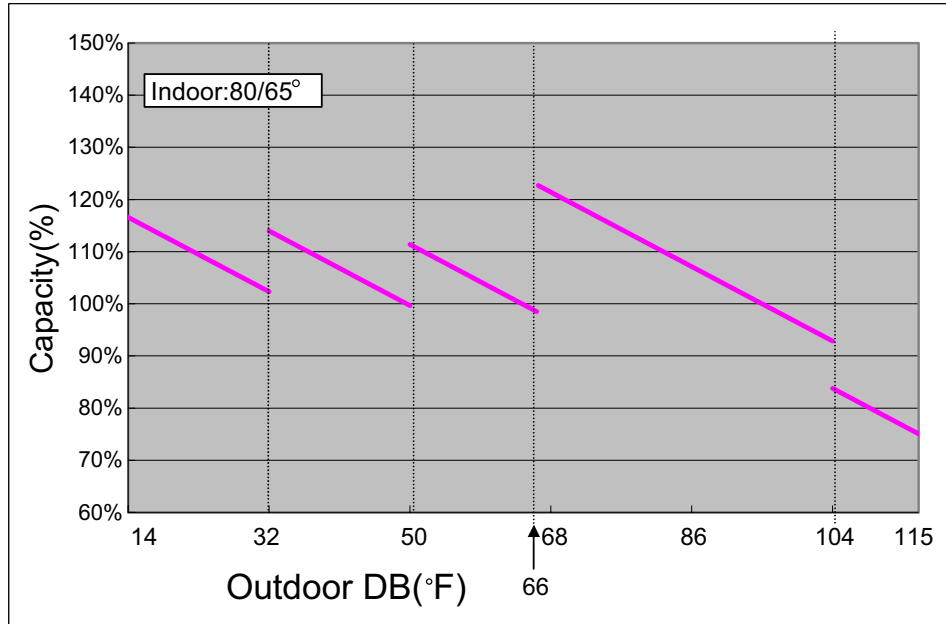

<Input>

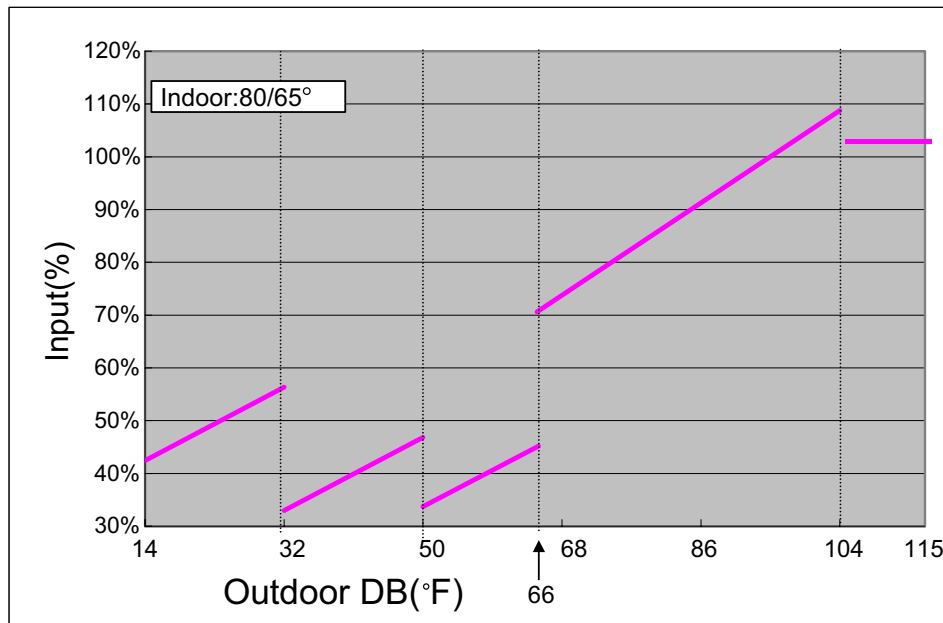

- *Both capacity and input decrease when temperature is 66 or less degrees F, for compressor frequency restrictions operate.
- *Both capacity and input decrease when temperature is 104 or more degrees F, as compressor speed is decreased due to current release protection.
- *Both capacity and input change largely when temperature is 50 or less degrees F, as outdoor fan speed is decreased due to low ambient temperature cooling control.
- *Both capacity and input change more largely at less than 32 degrees F of ambient temperature as outdoor fan speed is decreased further.

ASU18RL Capacity/Input data

Heating

<Capacity>

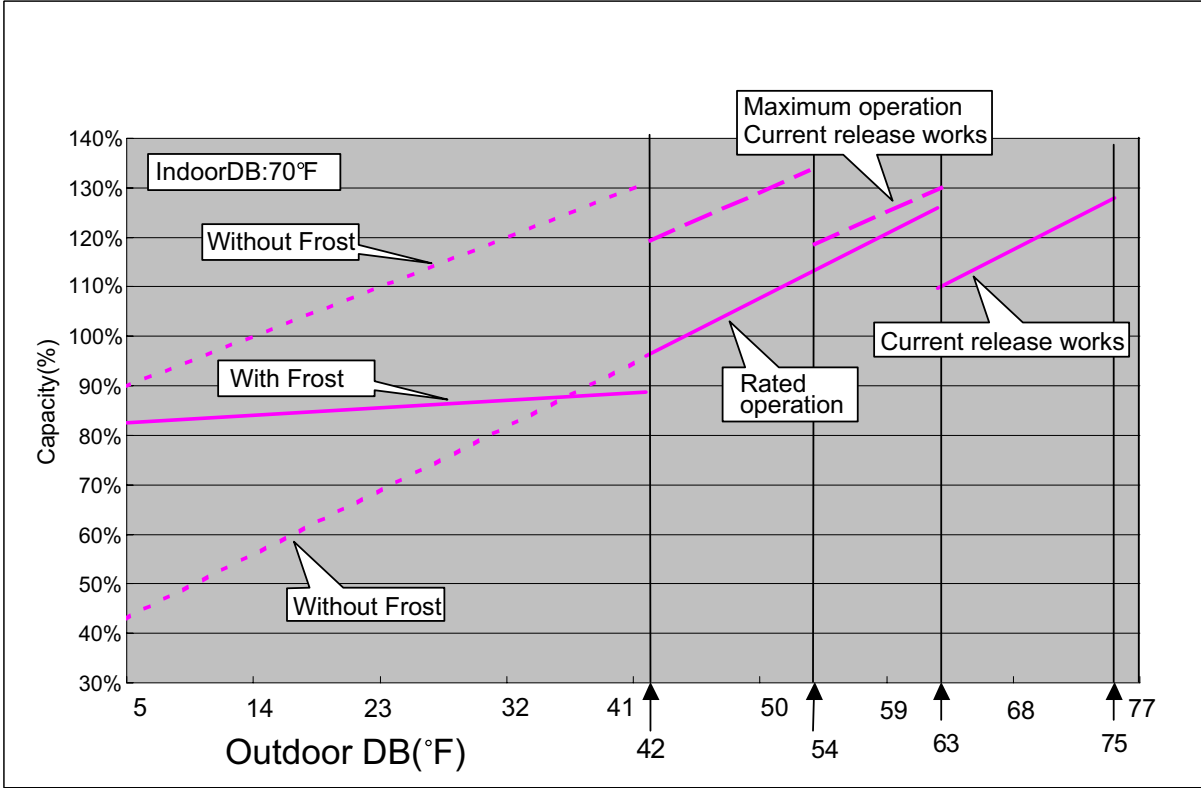

<Input>

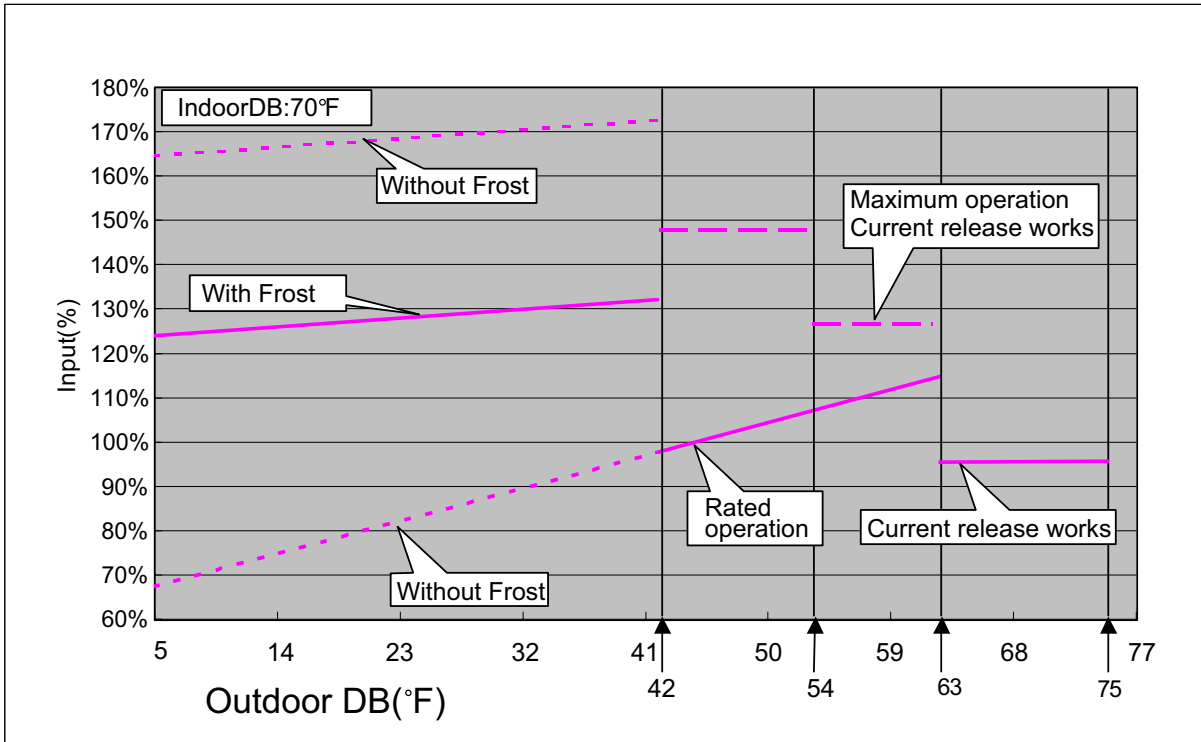

*Defrosting operation is performed when temperature is less than 42 degrees F.

Frost appears on an outdoor unit heat exchanger at 42 or less degrees F.

*Solid line: Integral capacity/Input containing the defrosting cycle.

*Dotted line: Capacity/Input which does not contain the defrosting cycle.

Cooling

<Capacity>

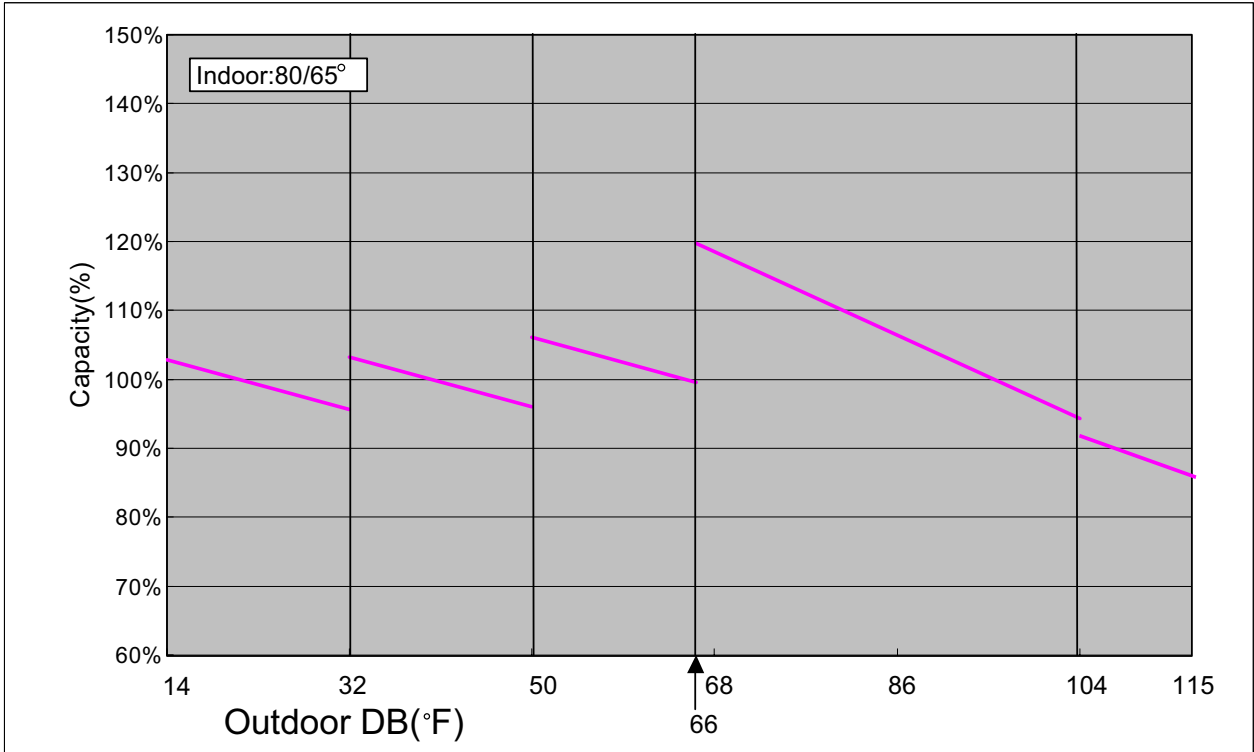

<Input>

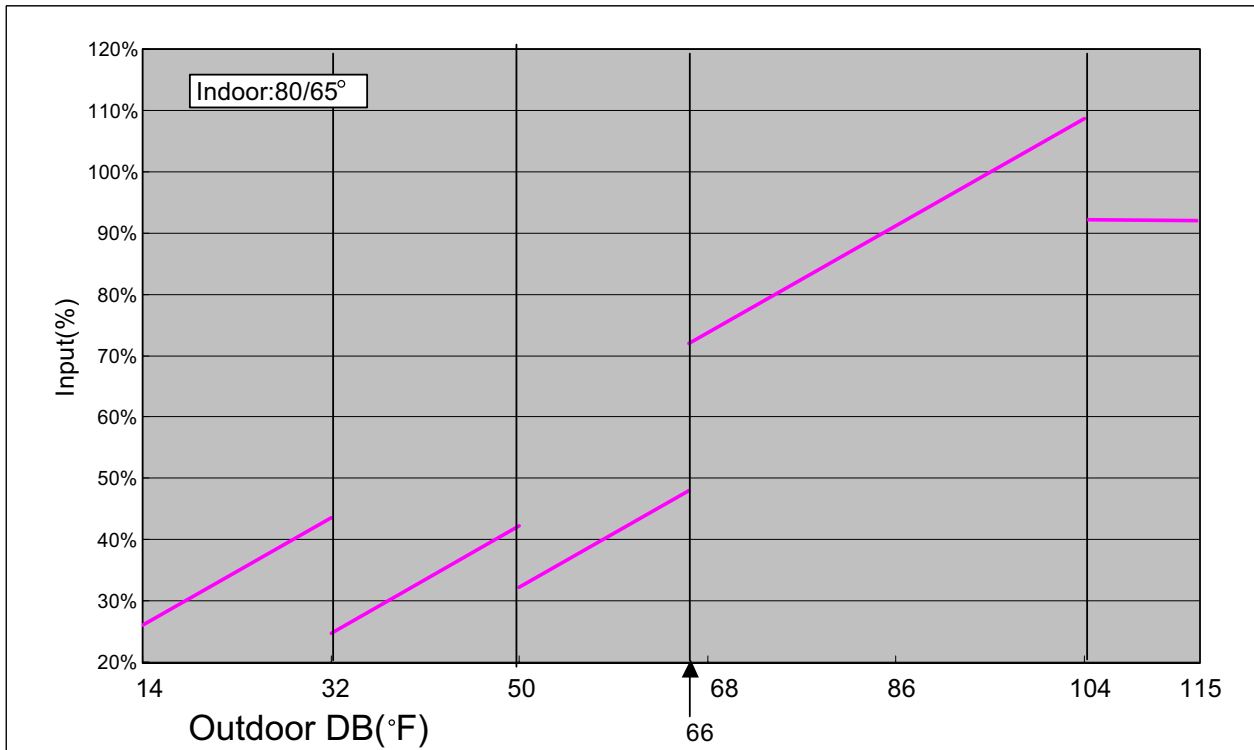

- *Both capacity and input decrease when temperature is 66 or less degrees F, for compressor frequency restrictions operate.
- *Both capacity and input decrease when temperature is 104 or more degrees F, as compressor speed is decreased due to current release protection.
- *Both capacity and input change largely when temperature is 50 or less degrees F, as outdoor fan speed is decreased due to low ambient temperature cooling control.
- *Both capacity and input change more largely at less than 32 degrees F of ambient temperature as outdoor fan speed is decreased further.

WALL MOUNTED type INVERTER

9 . REPLACEMENT PARTS

REPLACEMENT PARTS

Models : ASU9RLQ
ASU12RLQ

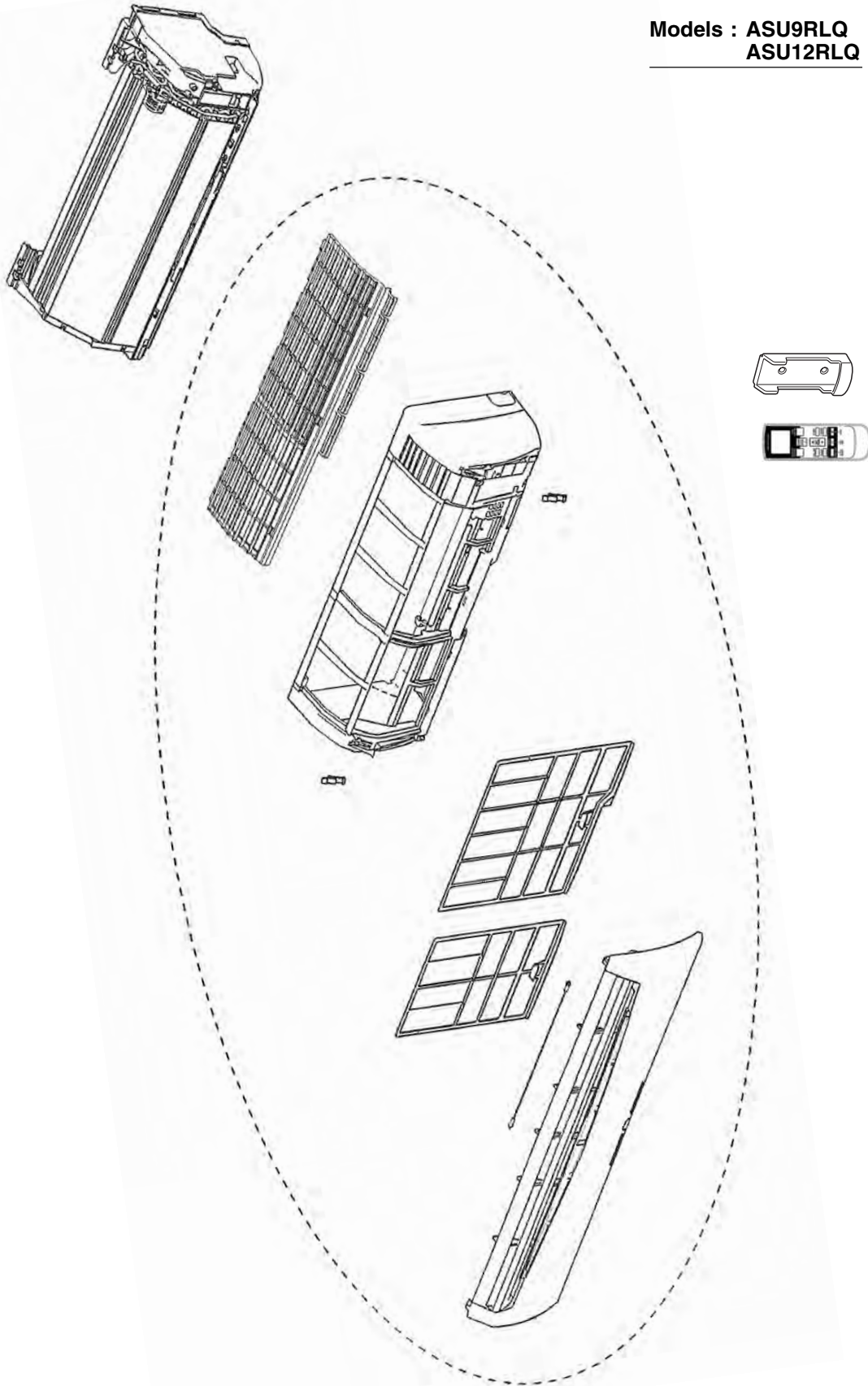

REPLACEMENT PARTS

Models : ASU9RLQ
ASU12RLQ

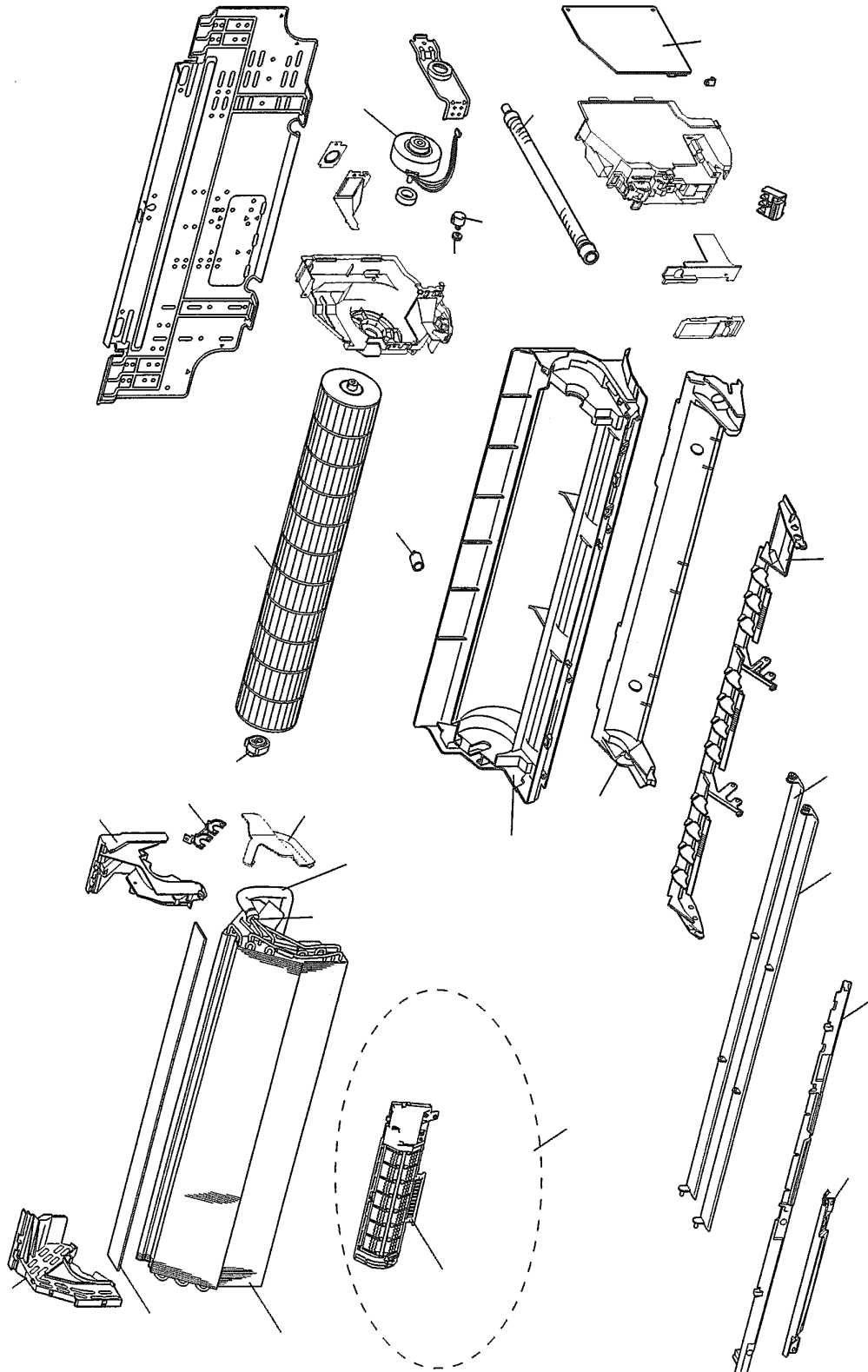

REPLACEMENT PARTS

Models : AOU9RLQ
AOU12RLQ

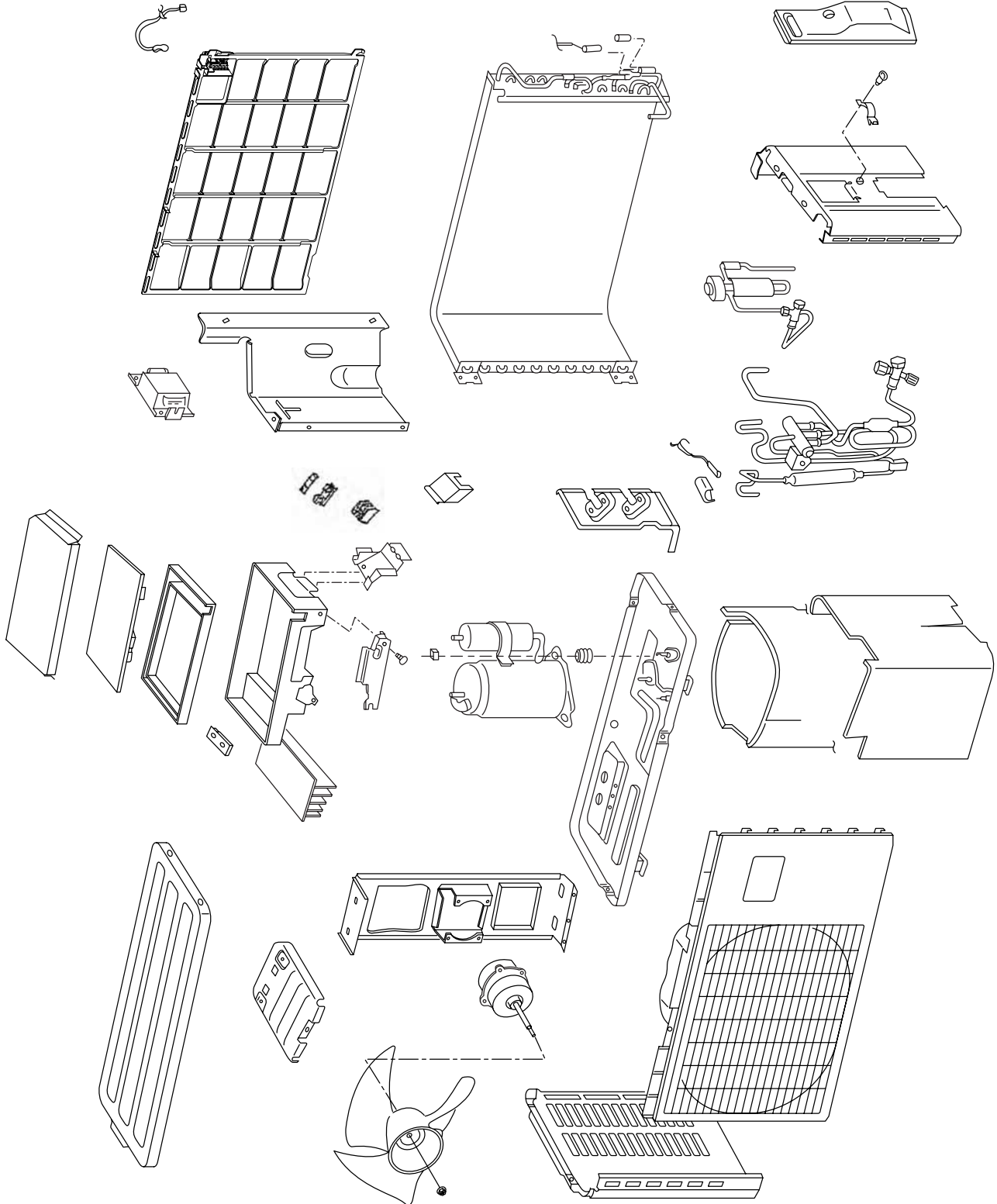

REPLACEMENT PARTS

Models : ASU18CL
ASU18RL

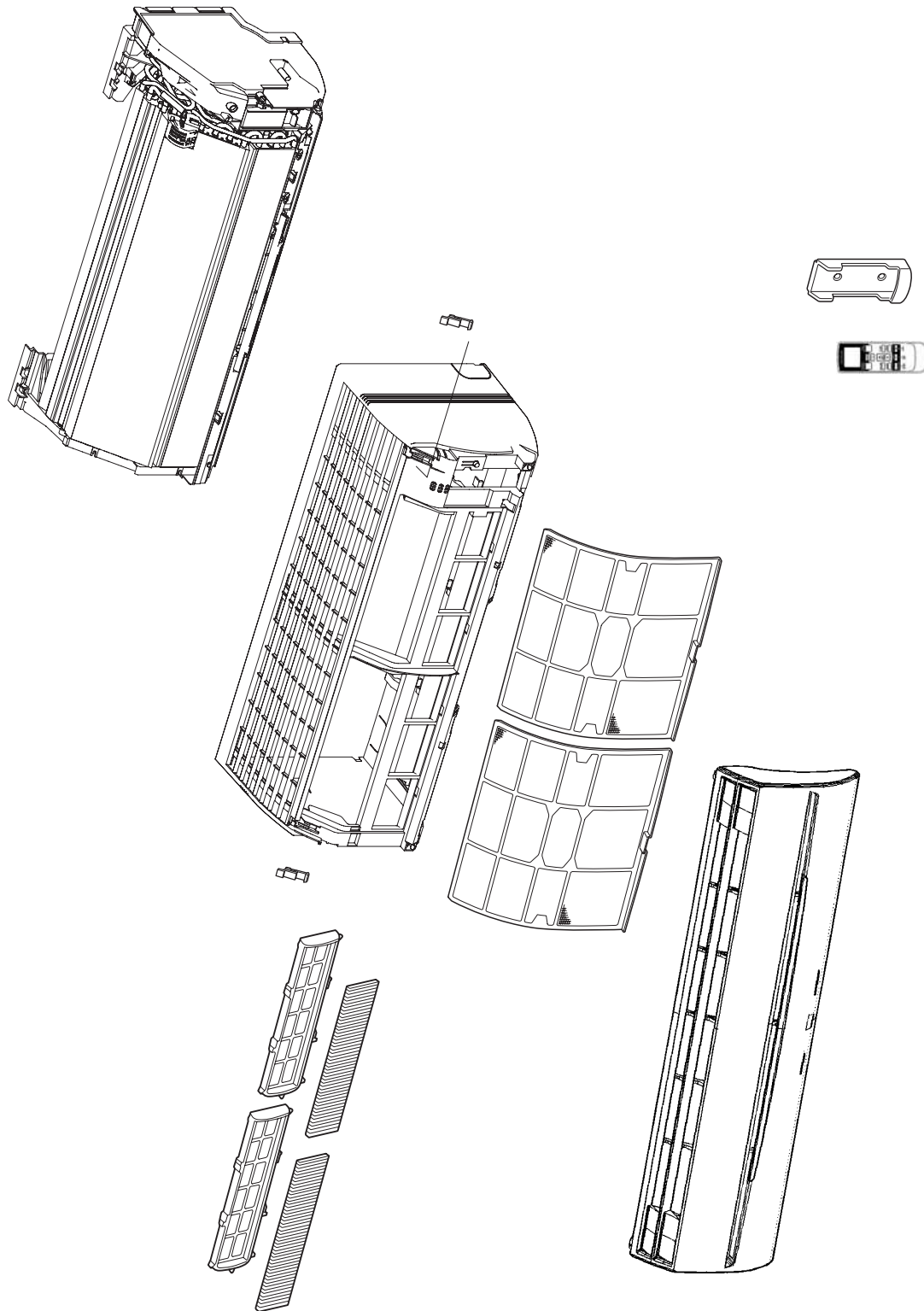

REPLACEMENT PARTS

Models : ASU18CL
ASU18RL

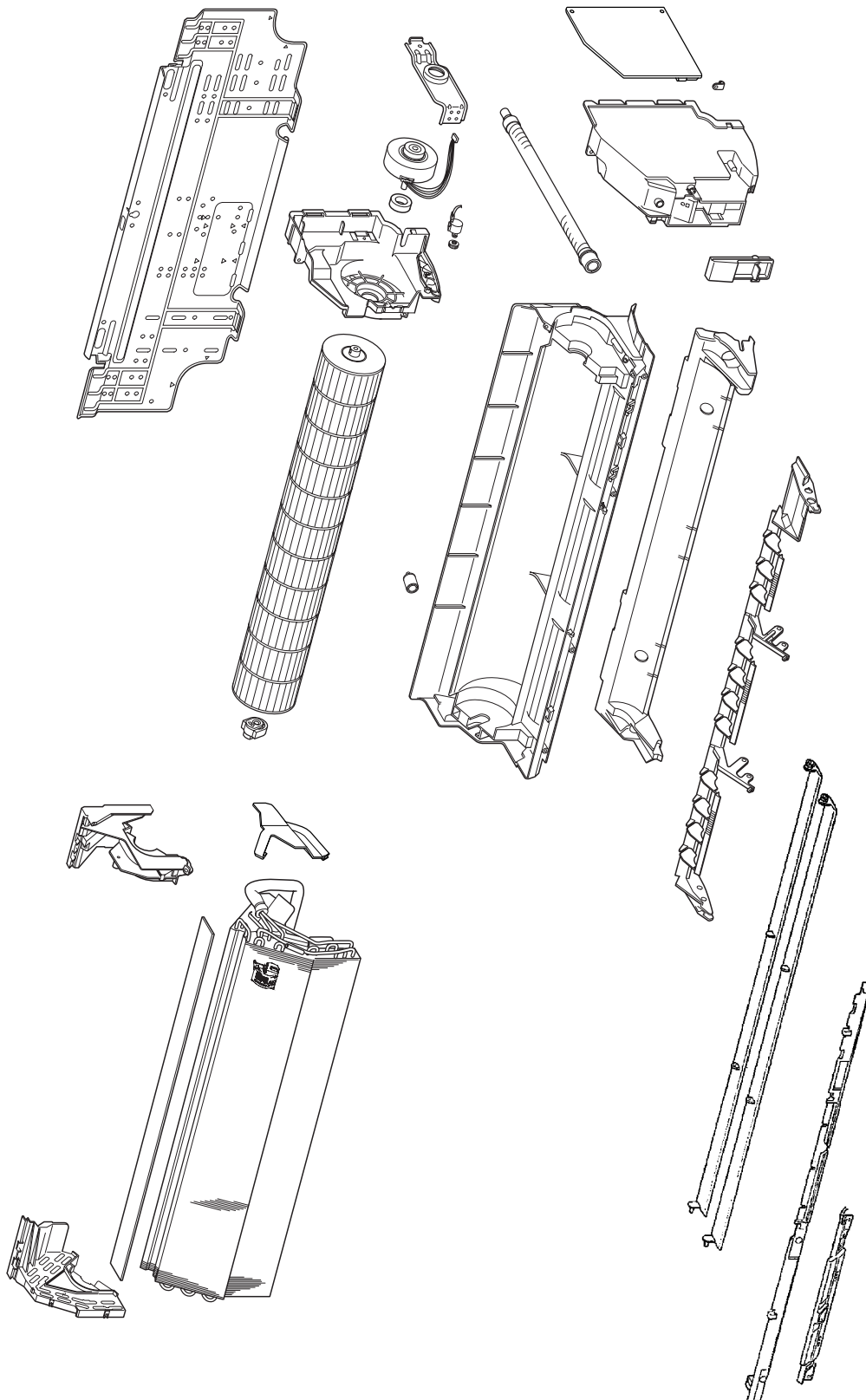

REPLACEMENT PARTS

Models : ASU18CL
ASU18RL

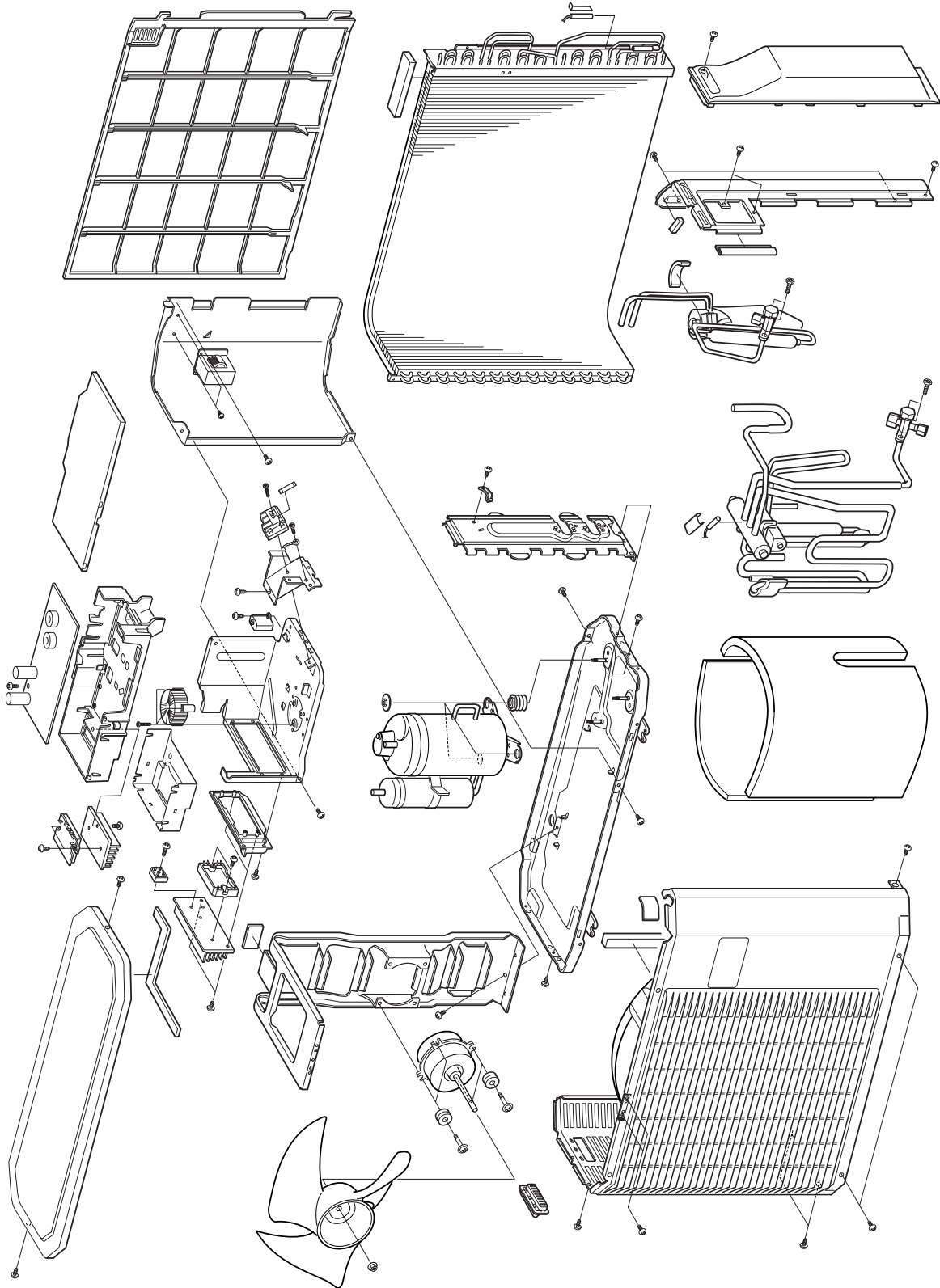

REPLACEMENT PARTS

PROCESS ATTACHMENT OF INVERTER ASSY

- ① INVERTER ASSY
- ② Tap tight screw

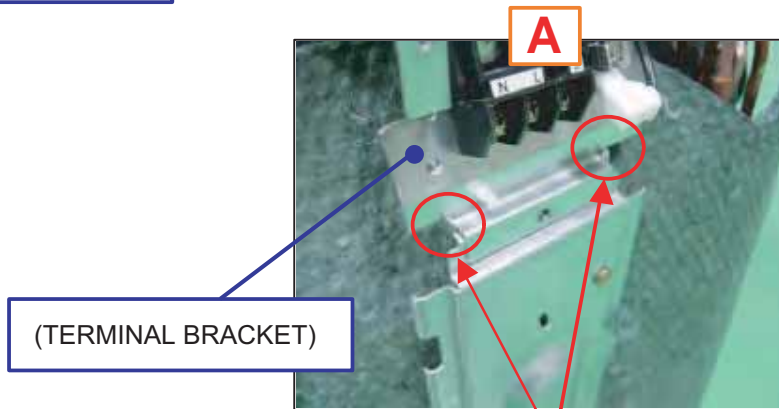

Do not run up the terminal board mounting metal on 2 location of hook.
THERMISTOR (OUT TEMP) is passed here.

REPLACEMENT PARTS

PROCESS The leads are connected with INVERTER ASSY

- ① MOTOR LEAD
- ② THERMISTOR ASSY (COND, DIS)
- ③ THERMISTOR (OUT TEMP)
- ④ SOLENOID LEAD
- ⑤ COIL (EXP VLV) LEAD
- ⑥ COMP LEAD
- ⑦ WIRE CLAMPER
- ⑧ REACTOR LEAD

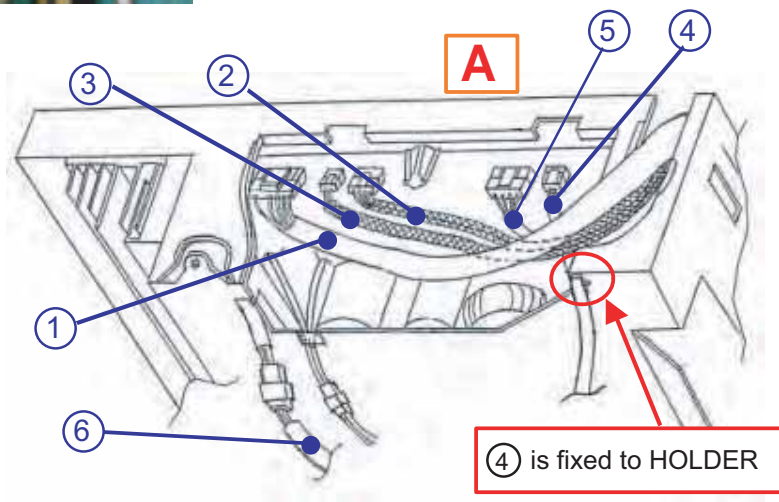
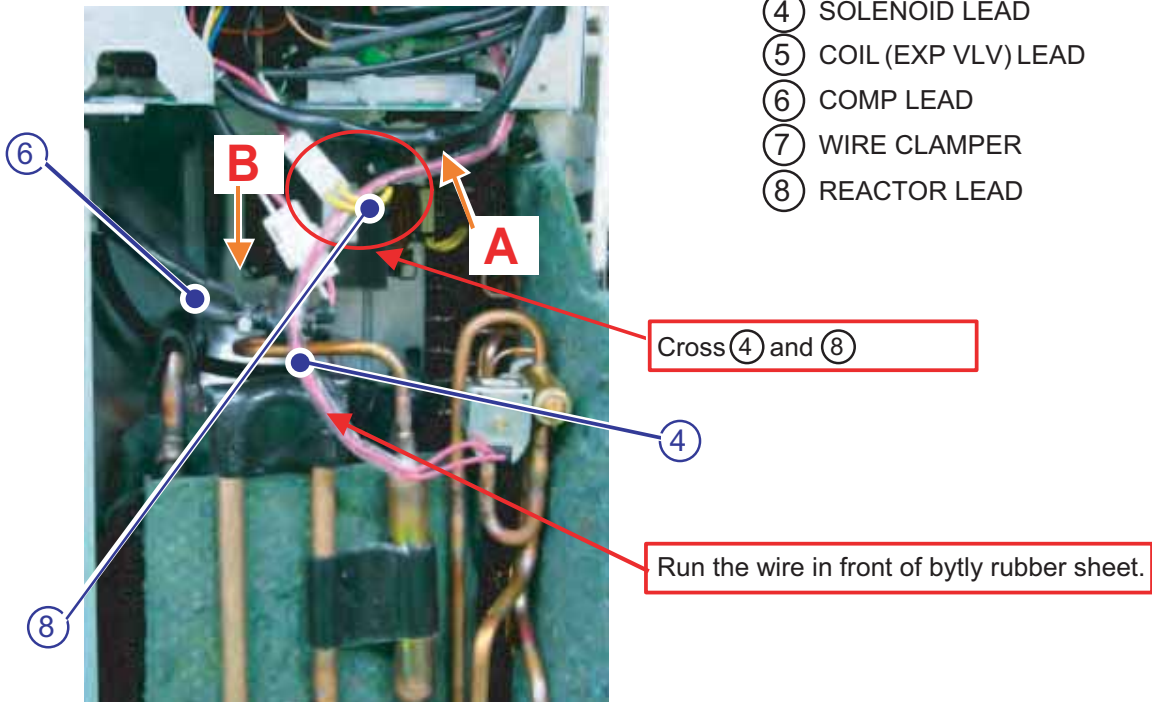

REPLACEMENT PARTS

PROCESS The leads are connected with INVERTER ASSY

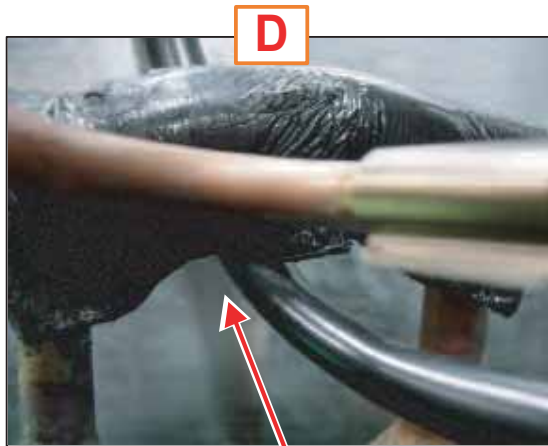
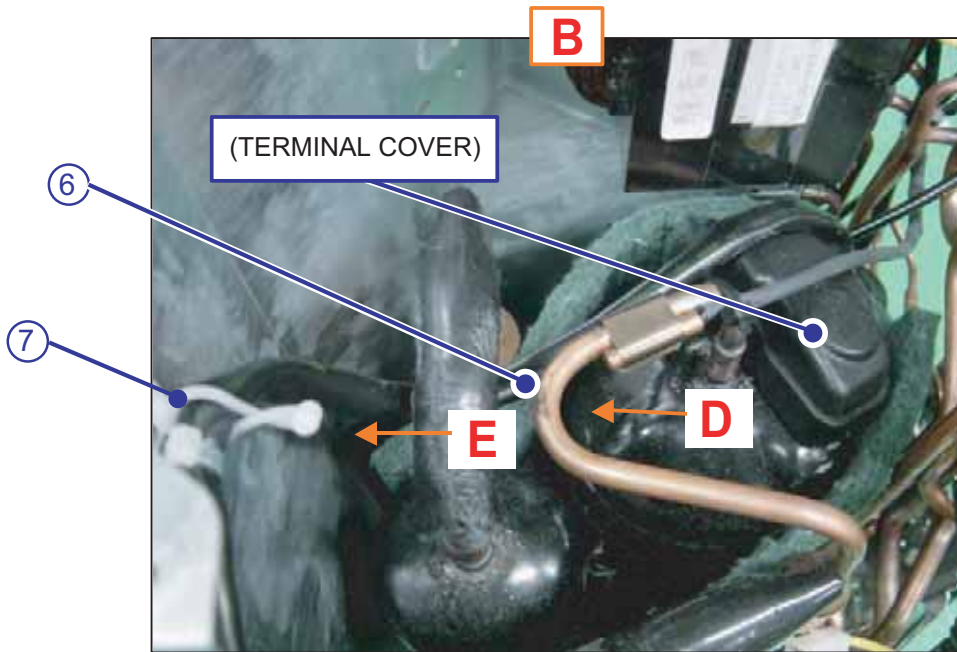

COMP LEAD is passed TERMINAL COVER the under.

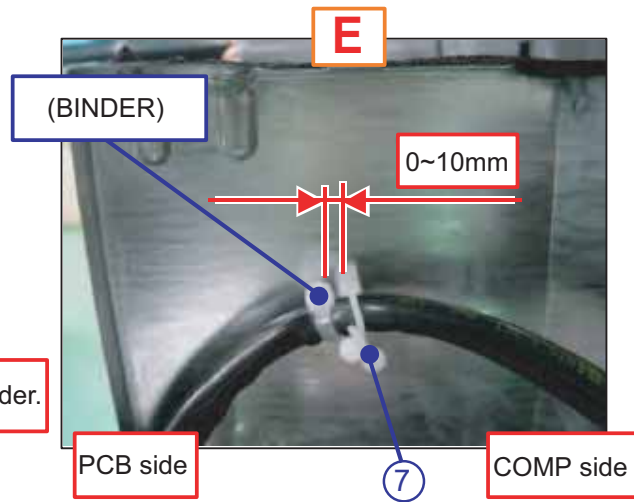

REPLACEMENT PARTS

PROCESS Fixing of Thermistor lead and motor lead.

- ① THERMISTOR ASSY (SUC/DIS)
- ② THERMISTOR (OUT TEMP)
- ③ MOTOR LEAD
- ④ COIL(EXP VLV)

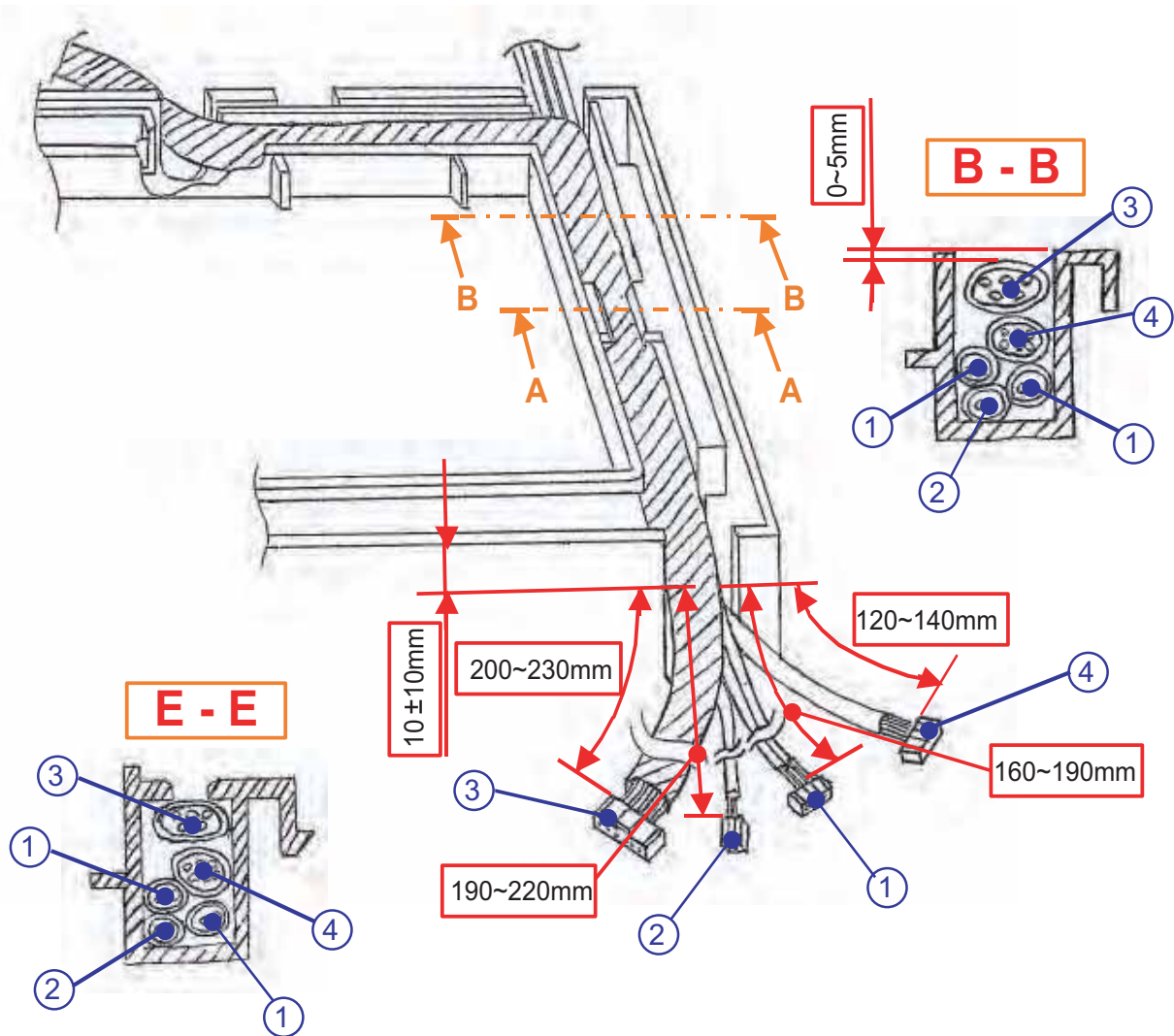

WALL MOUNTED type INVERTER

10 . INSTALLATION MANUAL



SPLIT TYPE ROOM AIR CONDITIONER INSTALLATION MANUAL

(P/N 9315140050-01)
(MODEL: ASU18R/AOU18RL; ASU18CL/AOU18CL)

ENGLISH

IMPORTANT!
Please Read Before Starting

- Connect all wiring safely. Loose wiring may cause overheating at indoor and/or outdoor units and a fire hazard.
- Do not touch the outdoor unit or indoor unit.
- Do not touch the outdoor unit or indoor unit.
- Do not touch the outdoor unit or indoor unit.
- Do not touch the outdoor unit or indoor unit.
- Do not touch the outdoor unit or indoor unit.
- Do not touch the outdoor unit or indoor unit.
- Do not touch the outdoor unit or indoor unit.
- Do not touch the outdoor unit or indoor unit.
- Do not touch the outdoor unit or indoor unit.
- Do not touch the outdoor unit or indoor unit.

For safe installation and trouble-free operation, you must:

- Check that the outdoor unit is installed on a level surface.
- Check that the indoor unit is installed in a suitable location.
- Check that the outdoor unit is installed in a suitable location.
- Check that the indoor unit is installed in a suitable location.
- Check that the outdoor unit is installed in a suitable location.
- Check that the indoor unit is installed in a suitable location.
- Check that the outdoor unit is installed in a suitable location.
- Check that the indoor unit is installed in a suitable location.
- Check that the outdoor unit is installed in a suitable location.
- Check that the indoor unit is installed in a suitable location.

WARNING: This symbol indicates a warning or a precaution which should be followed to avoid injury or death. Failure to follow these instructions may result in property damage, personal injury or even death.

CAUTION: This symbol indicates a warning or a precaution which should be followed to avoid injury or death. Failure to follow these instructions may result in property damage, personal injury or even death.

Special Precautions:

- Do not use the existing main gas and water pipes.
- Do not use the existing main gas and water pipes.
- Do not use the existing main gas and water pipes.
- Do not use the existing main gas and water pipes.
- Do not use the existing main gas and water pipes.
- Do not use the existing main gas and water pipes.
- Do not use the existing main gas and water pipes.
- Do not use the existing main gas and water pipes.
- Do not use the existing main gas and water pipes.
- Do not use the existing main gas and water pipes.

When Connecting Refrigerant Piping:

- Do not use the existing main gas and water pipes.
- Do not use the existing main gas and water pipes.
- Do not use the existing main gas and water pipes.
- Do not use the existing main gas and water pipes.
- Do not use the existing main gas and water pipes.
- Do not use the existing main gas and water pipes.
- Do not use the existing main gas and water pipes.
- Do not use the existing main gas and water pipes.
- Do not use the existing main gas and water pipes.
- Do not use the existing main gas and water pipes.

Check local electrical codes:

Check local electrical codes before obtaining wire. Also, check any specific instructions or limitations.

Check local gas codes:

Check local gas codes before obtaining gas. Also, check any specific instructions or limitations.

STANDARD ACCESSORIES:

Name and Qty	Quantity
Wall hook bracket	1
Drill bits	1
Drill	1
Splicing screw (5g)	1
Splicing screw (10g)	1
Splicing screw (15g)	1
Splicing screw (20g)	1
Splicing screw (25g)	1
Splicing screw (30g)	1
Splicing screw (35g)	1
Splicing screw (40g)	1
Splicing screw (45g)	1
Splicing screw (50g)	1
Splicing screw (55g)	1
Splicing screw (60g)	1
Splicing screw (65g)	1
Splicing screw (70g)	1
Splicing screw (75g)	1
Splicing screw (80g)	1
Splicing screw (85g)	1
Splicing screw (90g)	1
Splicing screw (95g)	1
Splicing screw (100g)	1

ELECTRICAL REQUIREMENT

Always make the air conditioner power supply a special branch circuit. Do not use the same circuit as other electrical equipment.

Model	Minimum Circuit Amperage	Power
ASU18R/AOU18RL	15A	1.8kW
ASU18CL/AOU18CL	20A	2.2kW

This air conditioner uses new refrigerant R410A.

The basic installation procedure for this air conditioner is as follows:

1. Cutting the hole in the wall for the connecting piping.
2. Installing the wall-hook bracket.
3. Forming the drain hose and pipe.
4. Connecting the piping.
5. Electrical wiring (outdoor unit).
6. Mounting the outdoor unit.
7. Mounting the indoor unit.
8. Testing and commissioning.

1. CUTTING THE HOLE IN THE WALL FOR THE CONNECTING PIPING

Check the hole diameter and depth before cutting the hole in the wall.

2. INSTALLING THE WALL-HOOK BRACKET

Install the wall-hook bracket on the wall. Make sure it is level and secure.

3. FORMING THE DRAIN HOSE AND PIPE

Form the drain hose and pipe according to the instructions. Ensure proper slope and sealing.

4. CONNECTING THE PIPING

Connect the indoor and outdoor units according to the piping instructions. Use proper techniques for joining pipes.

5. ELECTRICAL WIRING (OUTDOOR UNIT)

Wiring the outdoor unit must be done by a qualified electrician. Follow local codes and safety procedures.

6. MOUNTING THE OUTDOOR UNIT

Mount the outdoor unit on a level surface. Ensure it is secure and has adequate clearance.

7. MOUNTING THE INDOOR UNIT

Mount the indoor unit in a suitable location. Ensure it is level and secure.

8. TESTING AND COMMISSIONING

Test the system for leaks and proper operation. Commission the unit according to the instructions.

1. CUTTING THE HOLE IN THE WALL FOR THE CONNECTING PIPING

Use a hole saw to cut the hole in the wall. Make sure the hole is clean and free of debris.

2. INSTALLING THE WALL-HOOK BRACKET

Align the bracket with the hole and secure it with screws. Check for level.

3. FORMING THE DRAIN HOSE AND PIPE

Use a pipe bender to form the drain hose and pipe. Seal all joints properly.

4. CONNECTING THE PIPING

Use a pipe wrench to connect the indoor and outdoor units. Tighten all connections.

5. ELECTRICAL WIRING (OUTDOOR UNIT)

Run the wires through a conduit and connect them to the outdoor unit terminals.

6. MOUNTING THE OUTDOOR UNIT

Slide the outdoor unit into the hole and secure it with the provided hardware.

7. MOUNTING THE INDOOR UNIT

Slide the indoor unit into the hole and secure it with the provided hardware.

8. TESTING AND COMMISSIONING

Turn on the power and test the unit. Adjust settings as needed for optimal performance.

Fig. 4

For the indoor unit, cut the hole in the wall for the connecting piping.

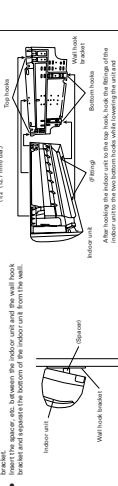

Fig. 5

Install the outdoor unit wall bracket with the optional in-wall bracket.

Fig. 6

Form the drain hose and pipe according to the instructions.

Fig. 7

Wiring the outdoor unit must be done by a qualified electrician.

Fig. 8

Mount the outdoor unit on a level surface.

Fig. 9

Mount the indoor unit in a suitable location.

Fig. 10

Test the system for leaks and proper operation.

Fig. 11

Commissioning the unit according to the instructions.

ELECTRICAL WIRING (OUTDOOR UNIT)

Remove the screws, then remove the control box cover.

Connect the outdoor unit wires and indoor wiring to the terminals.

Use the screws to install the control box cover.

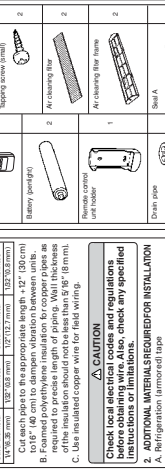

NOTE: Be sure to comply with local codes while running the wire from the indoor unit to the outdoor unit.

Every wire must be connected to the correct terminal. Loose wiring may cause the terminal to over-heat or result in unit malfunction.

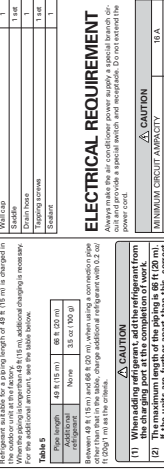

INDOOR UNIT INSTALLATION

Set the unit on a strong table, such as one made of concrete blocks.

Remove the connector cover.

Connect the indoor unit wires to the terminals.

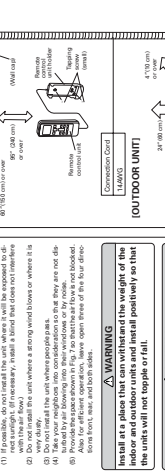

WARNING: Be sure to comply with local codes while running the wire from the indoor unit to the outdoor unit.

Every wire must be connected to the correct terminal.

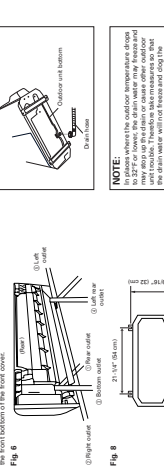

INDOOR UNIT

Check the hole diameter and depth before cutting the hole in the wall.

Install the wall-hook bracket on the wall.

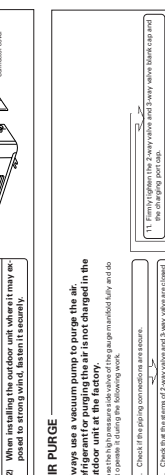

WARNING: Be sure to comply with local codes while running the wire from the indoor unit to the outdoor unit.

Every wire must be connected to the correct terminal.

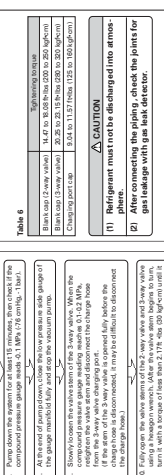

INDOOR UNIT

Check the hole diameter and depth before cutting the hole in the wall.

Install the wall-hook bracket on the wall.

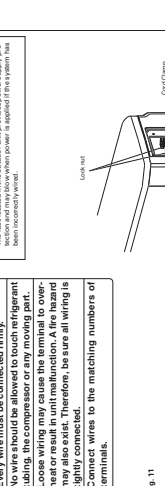

WARNING: Be sure to comply with local codes while running the wire from the indoor unit to the outdoor unit.

Every wire must be connected to the correct terminal.

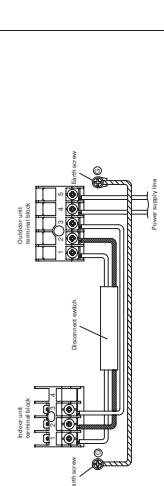



ELECTRICAL WIRING (INDOOR UNIT)

HOW TO INSTALL THE INTERMIT WIRE HARNESS

- Remove the cover of the control panel by using the lock.
- Remove the cover of the control panel by using the lock.
- Use the screw to install the intermit wire harness with which intermit wire harness is supplied.
- Remove the cover of the control panel by using the lock.
- Refer to the wiring diagram.
- Use the screw to install the cord clamp.

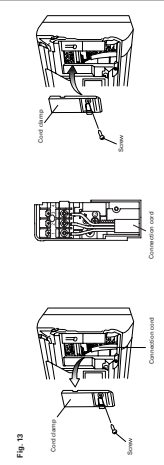

Fig. 13

HOW TO CONNECT WIRING TO THE TERMINALS

A. For cable wiring (or F-cable)

- Strip the insulation of the cable wires to the recommended length.
- Strip the insulation of the cable wires to the recommended length.
- Strip the insulation of the cable wires to the recommended length.
- Strip the insulation of the cable wires to the recommended length.

B. For strand wiring

- Strip the insulation of the cable wires to the recommended length.
- Strip the insulation of the cable wires to the recommended length.
- Strip the insulation of the cable wires to the recommended length.
- Strip the insulation of the cable wires to the recommended length.

Fig. 14

CAUTION

- Match the terminal block numbers and connection cord with the cord of the outdoor unit.
- Erroneous wiring may cause burning of the electrical parts.
- Do not use the earth screw for an external connector.
- Block, imperfect installation may cause a fire.

FINISHING

- Check the front panel.
- Check the front panel.
- Check the front panel.
- Check the front panel.



Fig. 15

FRONT PANEL REMOVAL AND INSTALLATION

THE INTAKE GRILLE REMOVAL

- Remove the intake grille.
- Remove the intake grille.
- Remove the intake grille.
- Remove the intake grille.

THE FRONT PANEL INSTALLATION

- Install the front panel.
- Install the front panel.
- Install the front panel.
- Install the front panel.

Fig. 17

CAUTION

- Do not touch the front panel.
- Do not touch the front panel.

TEST RUNNING

- Perform test operation and check items 1 and 2 below.
- Perform test operation and check items 1 and 2 below.
- Perform test operation and check items 1 and 2 below.
- Perform test operation and check items 1 and 2 below.

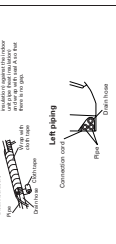

Fig. 18

POWER

WARNING

- The rated voltage of this product is 230V/50 Hz AC.
- The power source capacity must be the sum of the rated capacity of the indoor and outdoor electrical appliances.
- Always use a special branch circuit and install a circuit breaker with a capacity of 20A or more.
- Use a circuit breaker and capacitor matched to the capacity of the air conditioner.

CAUTION

- Do not connect the power cord to the power outlet with the capacity of 20A or more.
- Do not connect the power cord to the power outlet with the capacity of 20A or more.
- Do not connect the power cord to the power outlet with the capacity of 20A or more.

CAUTION

- During the pump-down operation, make sure that the compressor is turned off before you remove the refrigerant piping.
- Do not touch the refrigerant piping with any sharp object.

PUMP DOWN OPERATION (FORCED COOLING OPERATION)

- Do the pump-down operation by connecting the charging hose to the charging port of 3-way valve and opening the 3-way valve.
- Do the pump-down operation by connecting the charging hose to the charging port of 3-way valve and opening the 3-way valve.
- Do the pump-down operation by connecting the charging hose to the charging port of 3-way valve and opening the 3-way valve.
- Do the pump-down operation by connecting the charging hose to the charging port of 3-way valve and opening the 3-way valve.



Fig. 19

REMOTE CONTROL UNIT (OPTIONAL)

BEFORE INSTALL WIRED REMOTE CONTROL UNIT

- When you use wired remote control unit, some functions may not be used.
- Please use the recommended wired remote control unit.

CAUTION

- Before installing, be sure to disconnect all power supply.
- Don't touch the heat exchanger.
- Be sure not to have wire touched by parts or draw it back. Or it may result trouble to the air conditioner.
- Avoid place in direct sunlight.
- Select place that will not be affected by the heat from a stove, etc.
- Ensure the length of wire is not over the recommended maximum length.
- When setting up the wired remote control unit, please confirm whether air conditioner can receive the signal.

1. FRONT PANEL AND CONTROL UNIT REMOVAL

- Remove screws of the heat exchanger, and then remove ground wire.
- Remove screws, then remove the sensor cover and connector.
- Remove screws, then remove the control unit.

THE METHOD OF ADJUSTING INTERMIT WIRE HARNESS

- Refer to Fig. 19 to adjust the length of the part of intermit wire harness attached to control panel.
- Refer to Fig. 19 to adjust the length of the part of intermit wire harness attached to control panel.
- Refer to Fig. 19 to adjust the length of the part of intermit wire harness attached to control panel.
- Refer to Fig. 19 to adjust the length of the part of intermit wire harness attached to control panel.

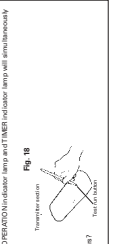

Fig. 19

REMOTE CONTROL UNIT INSTALLATION

CAUTION

- Check that the indoor unit correctly receives the signal from the remote control unit, then install the remote control unit.
- Select the remote control unit holder selection site by paying careful attention to the following:
 - Select a place that will not be affected by the heat from a stove, etc.

1. REMOTE CONTROL UNIT HOLDER INSTALLATION

- Install the remote control unit holder with a distance of 230mm between the remote control unit and the photo-cell.
- Install the remote control unit holder to a wall, pillar, etc. with the tapping screw (Fig. 20).

Fig. 20



THE METHOD OF ADJUSTING INTERMIT WIRE HARNESS

- Refer to Fig. 19 to adjust the length of the part of intermit wire harness attached to control panel.
- Refer to Fig. 19 to adjust the length of the part of intermit wire harness attached to control panel.
- Refer to Fig. 19 to adjust the length of the part of intermit wire harness attached to control panel.
- Refer to Fig. 19 to adjust the length of the part of intermit wire harness attached to control panel.

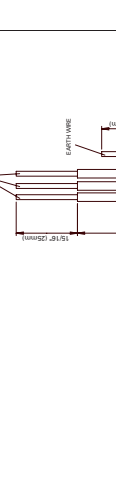

Fig. 19

REMOTE CONTROL UNIT (OPTIONAL)

BEFORE INSTALL WIRED REMOTE CONTROL UNIT

- When you use wired remote control unit, some functions may not be used.
- Please use the recommended wired remote control unit.

CAUTION

- Before installing, be sure to disconnect all power supply.
- Don't touch the heat exchanger.
- Be sure not to have wire touched by parts or draw it back. Or it may result trouble to the air conditioner.
- Avoid place in direct sunlight.
- Select place that will not be affected by the heat from a stove, etc.
- Ensure the length of wire is not over the recommended maximum length.
- When setting up the wired remote control unit, please confirm whether air conditioner can receive the signal.

1. FRONT PANEL AND CONTROL UNIT REMOVAL

- Remove screws of the heat exchanger, and then remove ground wire.
- Remove screws, then remove the sensor cover and connector.
- Remove screws, then remove the control unit.

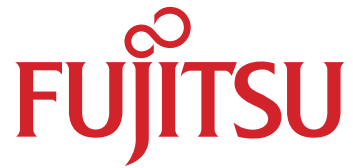

FUJITSU GENERAL LIMITED

1116, Suenaga, Takatsu-ku, Kawasaki 213-8502, Japan