

Peerless® PUREFIRE® PFW™ Series

High Efficiency, Large Volume Hot Water Supply Boilers



- Efficiencies Over 93%!—ENERGY STAR® Rated!
- Boilers are compliant with the Lead-Free requirements of the Safe Drinking Water Act
- Natural or LP Gas Fired Boiler with Low NO_x Operation
- Flow Switch Provides Precise Signal for Hot Water Demand
- Cascade up to 8 Boilers for Larger Volume Applications — No Extra Controls Needed!
- Stainless Steel Heat Exchanger for Long Service Life
- Flexible Vent Options Including Direct Vent and Chimney Liners
- Vents up to 200 Feet Combined
- Parts AND LABOR Warranty for First Year! (See Warranty Statement for details)

Standard Equipment

- > Built-in Condensate Neutralizer System with Float Switch Protection
- > State-of-the-Art Control Board with Advanced Features
- > High Grade Stainless Steel Burner and Heat Exchanger
- > Flow Switch
- > PVC Screened Air Intake and Exhaust

Have a PureFire® Boiler? Turn it into a PFW™ Series volume hot water boiler with an easy conversion kit! See your local dealer or rep for more information!

The PUREFIRE® PFW™ series includes a full one-year warranty. A one-year parts and labor warranty will also be provided (labor coverage starting on day 91) if the boiler is fully registered (online registration). In addition, the heat exchanger is covered by a 12-year limited warranty. Visit PeerlessBoilers.com for complete details.



CONTROLS



Technical Information

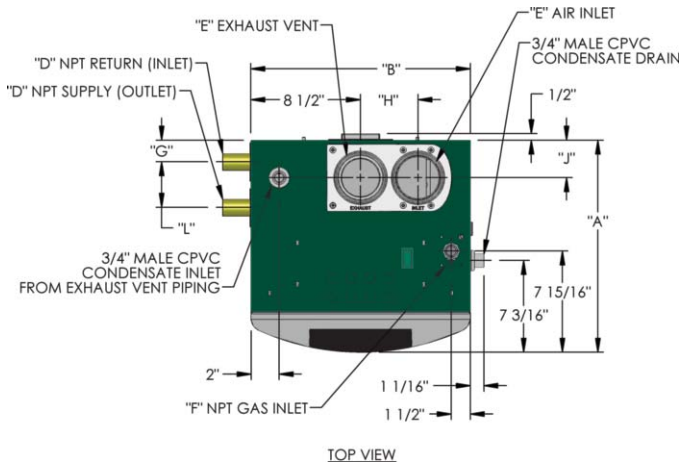

Carton Dimensions & Shipping Weights

Boiler Model Number	Length	Width	Height	Approximate Shipping Weight (lbs.)
PFW-200	21"	24"	48"	165
PFW-399	25"	32"	50"	255

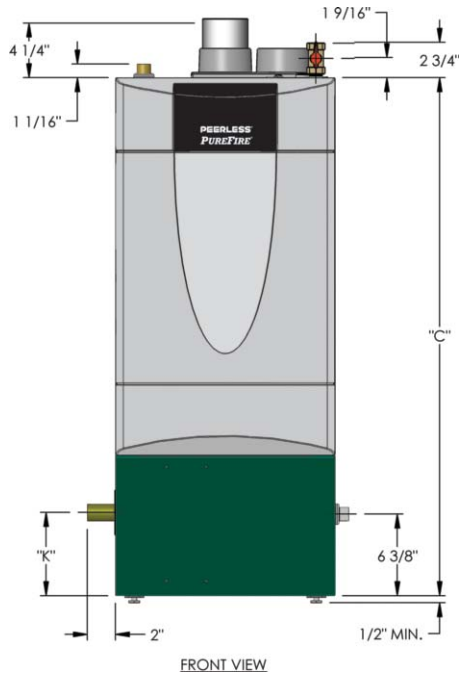

Boiler Ratings

PUREFIRE® Gas Series					
Boiler Model Number	Input, MBH		Heating Capacity ² , MBH	Net Water Ratings ²	AFUE ² , %
	Min	Max			
PFW-200	42	199	183	159	93.3
			Gross Output, MBH		Thermal Efficiency, %
PFW-399	80	399	373	324	93.4

Note: Consult factory before selecting a boiler for installations having unusual piping and pickup requirements, such as intermittent system operation, extensive piping systems, etc.

- 1 Heating Capacity and Annual Fuel Utilization Efficiency (AFUE) ratings are based on U.S. Government test. Before purchasing this appliance, read important information about its estimated annual energy consumption or energy efficiency rating that is available from your retailer.
- 2 Net water ratings are based on an allowance of 1.15.

Dimensions & Connection Sizes

Boiler Model Number	Dimensions										
	A	B	C	D	E	F	G	H	J	K	L
PFW-200	16-9/16"	17-3/16"	40-1/2"	1"	3"	3/4"	1-3/4"	4-1/2"	3"	6-1/2"	3-9/16"
PFW-399	27-15/16"	17-3/16"	40-1/2"	1-1/2"	4"	3/4"	2-3/4"	5-1/4"	3-1/2"	5-3/4"	7-1/16"



PeerlessBoilers.com



Printed on Recycled Paper

PeerlessBoilers.com

CUT-PFW R0 (07/14-3M)
Printed in U.S.A.
©2014 PB Heat, LLC. All rights reserved.